

# Basic Nodal and Mesh Analysis

## INTRODUCTION

Armed with the trio of Ohm's and Kirchhoff's laws, analyzing a simple linear circuit to obtain useful information such as the current, voltage, or power associated with a particular element is perhaps starting to seem a straightforward enough venture. Still, for the moment at least, every circuit seems unique, requiring (to some degree) a measure of creativity in approaching the analysis. In this chapter, we learn two basic circuit analysis techniques—*nodal analysis* and *mesh analysis*—both of which allow us to investigate many different circuits with a consistent, methodical approach. The result is a streamlined analysis, a more uniform level of complexity in our equations, fewer errors and, perhaps most importantly, a reduced occurrence of “*I don't know how to even start!*”

Most of the circuits we have seen up to now have been rather simple and (to be honest) of questionable practical use. Such circuits are valuable, however, in helping us to learn to apply fundamental techniques. Although the more complex circuits appearing in this chapter may represent a variety of electrical systems including control circuits, communication networks, motors, or integrated circuits, as well as electric circuit models of nonelectrical systems, we believe it best not to dwell on such specifics at this early stage. Rather, it is important to initially focus on the *methodology of problem solving* that we will continue to develop throughout the book.

## KEY CONCEPTS

Nodal Analysis

The Supernode Technique

Mesh Analysis

The Supermesh Technique

Choosing Between Nodal and Mesh Analysis

Computer-Aided Analysis, Including PSpice and MATLAB



## 4.1 NODAL ANALYSIS

We begin our study of general methods for methodical circuit analysis by considering a powerful method based on KCL, namely *nodal analysis*. In Chap. 3 we considered the analysis of a simple circuit containing only two nodes. We found that the major step of the analysis was obtaining a single equation in terms of a single unknown quantity—the voltage between the pair of nodes.

We will now let the number of nodes increase and correspondingly provide one additional unknown quantity and one additional equation for each added node. Thus, a three-node circuit should have two unknown voltages and two equations; a 10-node circuit will have nine unknown voltages and nine equations; an  $N$ -node circuit will need  $(N - 1)$  voltages and  $(N - 1)$  equations. Each equation is a simple KCL equation.

To illustrate the basic technique, consider the three-node circuit shown in Fig. 4.1a, redrawn in Fig. 4.1b to emphasize the fact that there are only three nodes, numbered accordingly. Our goal will be to determine the voltage across each element, and the next step in the analysis is critical. We designate one node as a *reference node*; it will be the negative terminal of our  $N - 1 = 2$  nodal voltages, as shown in Fig. 4.1c.

A little simplification in the resultant equations is obtained if the node connected to the greatest number of branches is identified as the reference node. If there is a ground node, it is usually most convenient to select it as the reference node, although many people seem to prefer selecting the bottom node of a circuit as the reference, especially if no explicit ground is noted.

The voltage of node 1 *relative to the reference node* is named  $v_1$ , and  $v_2$  is defined as the voltage of node 2 with respect to the reference node. These

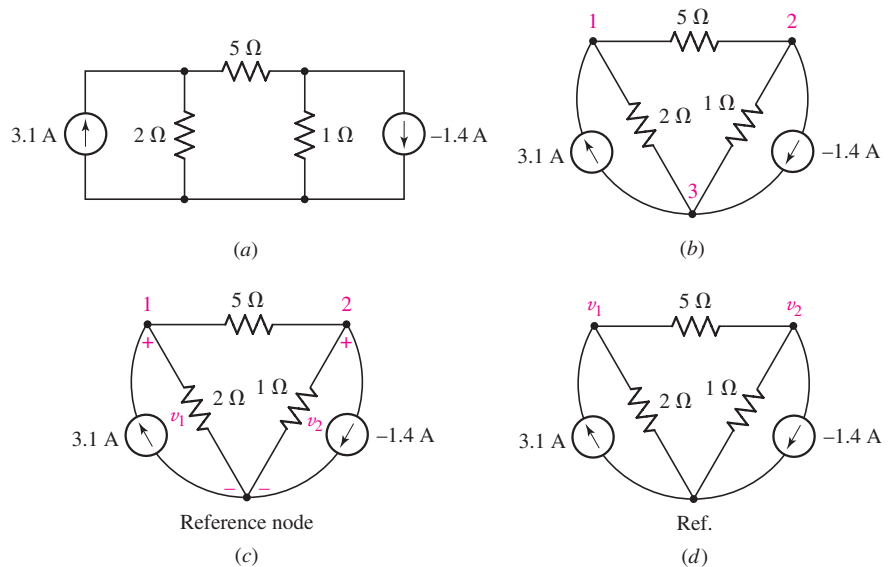

■ FIGURE 4.1 (a) A simple three-node circuit. (b) Circuit redrawn to emphasize nodes. (c) Reference node selected and voltages assigned. (d) Shorthand voltage references. If desired, an appropriate ground symbol may be substituted for "Ref."

two voltages are all we need, as the voltage between any other pair of nodes may be found in terms of them. For example, the voltage of node 1 with respect to node 2 is  $v_1 - v_2$ . The voltages  $v_1$  and  $v_2$  and their reference signs are shown in Fig. 4.1c. It is common practice once a reference node has been labeled to omit the reference signs for the sake of clarity; the node labeled with the voltage is taken to be the positive terminal (Fig. 4.1d). This is understood to be a type of shorthand voltage notation.

We now apply KCL to nodes 1 and 2. We do this by equating the total current leaving the node through the several resistors to the total source current entering the node. Thus,

$$\frac{v_1}{2} + \frac{v_1 - v_2}{5} = 3.1 \quad [1]$$

or

$$0.7v_1 - 0.2v_2 = 3.1 \quad [2]$$

At node 2 we obtain

$$\frac{v_2}{1} + \frac{v_2 - v_1}{5} = -(-1.4) \quad [3]$$

or

$$-0.2v_1 + 1.2v_2 = 1.4 \quad [4]$$

Equations [2] and [4] are the desired two equations in two unknowns, and they may be solved easily. The results are  $v_1 = 5$  V and  $v_2 = 2$  V.

From this, it is straightforward to determine the voltage across the  $5\ \Omega$  resistor:  $v_{5\Omega} = v_1 - v_2 = 3$  V. The currents and absorbed powers may also be computed in one step.

We should note at this point that there is more than one way to write the KCL equations for nodal analysis. For example, the reader may prefer to sum all the currents entering a given node and set this quantity to zero. Thus, for node 1 we might have written

$$3.1 - \frac{v_1}{2} - \frac{v_1 - v_2}{5} = 0$$

or

$$3.1 + \frac{-v_1}{2} + \frac{v_2 - v_1}{5} = 0$$

either of which is equivalent to Eq. [1].

*Is one way better than any other?* Every instructor and every student develop a personal preference, and at the end of the day the most important thing is to be consistent. The authors prefer constructing KCL equations for nodal analysis in such a way as to end up with all current source terms on one side and all resistor terms on the other. Specifically,

$$\begin{aligned} \sum \text{currents entering the node from current sources} \\ = \sum \text{currents leaving the node through resistors} \end{aligned}$$

There are several advantages to such an approach. First, there is never any confusion regarding whether a term should be " $v_1 - v_2$ " or " $v_2 - v_1$ ;" the

The reference node in a schematic is implicitly defined as zero volts. However, it is important to remember that any terminal can be designated as the reference terminal. Thus, the reference node is at zero volts with respect to the other defined nodal voltages, and not necessarily with respect to *earth* ground.

first voltage in every resistor current expression corresponds to the node for which a KCL equation is being written, as seen in Eqs. [1] and [3]. Second, it allows a quick check that a term has not been accidentally omitted. Simply count the current sources connected to a node and then the resistors; grouping them in the stated fashion makes the comparison a little easier.

### EXAMPLE 4.1

**Determine the current flowing left to right through the 15  $\Omega$  resistor of Fig. 4.2a.**

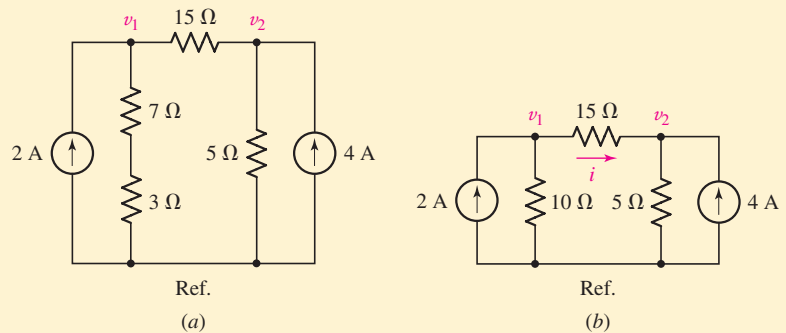

■ FIGURE 4.2 (a) A four-node circuit containing two independent current sources. (b) The two resistors in series are replaced with a single 10  $\Omega$  resistor, reducing the circuit to three nodes.

Nodal analysis will directly yield numerical values for the nodal voltages  $v_1$  and  $v_2$ , and the desired current is given by  $i = (v_1 - v_2)/15$ .

Before launching into nodal analysis, however, we first note that no details regarding either the 7  $\Omega$  resistor or the 3  $\Omega$  resistor are of interest. Thus, we may replace their series combination with a 10  $\Omega$  resistor as in Fig. 4.2b. The result is a reduction in the number of equations to solve.

Writing an appropriate KCL equation for node 1,

$$2 = \frac{v_1}{10} + \frac{v_1 - v_2}{15} \quad [5]$$

and for node 2,

$$4 = \frac{v_2}{5} + \frac{v_2 - v_1}{15} \quad [6]$$

Rearranging, we obtain

$$5v_1 - 2v_2 = 60$$

and

$$-v_1 + 4v_2 = 60$$

Solving, we find that  $v_1 = 20$  V and  $v_2 = 20$  V so that  $v_1 - v_2 = 0$ . In other words, **zero current** is flowing through the 15  $\Omega$  resistor in this circuit!

## PRACTICE

4.1 For the circuit of Fig. 4.3, determine the nodal voltages  $v_1$  and  $v_2$ .

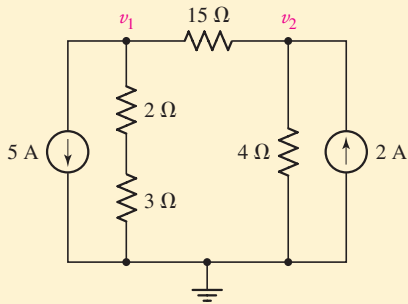

FIGURE 4.3

Ans:  $v_1 = -145/8$  V,  $v_2 = 5/2$  V.

Now let us increase the number of nodes so that we may use this technique to work a slightly more difficult problem.

## EXAMPLE 4.2

Determine the nodal voltages for the circuit of Fig. 4.4a, as referenced to the bottom node.

► **Identify the goal of the problem.**

There are four nodes in this circuit. With the bottom node as our reference, we label the other three nodes as shown in Fig. 4.4b. The circuit has been redrawn for clarity, taking care to identify the two relevant nodes for the  $4 \Omega$  resistor.

► **Collect the known information.**

We have three unknown voltages,  $v_1$ ,  $v_2$ , and  $v_3$ . All current sources and resistors have designated values, which are marked on the schematic.

► **Devise a plan.**

This problem is well suited to nodal analysis, as three independent KCL equations may be written in terms of the current sources and the current through each resistor.

► **Construct an appropriate set of equations.**

We begin by writing a KCL equation for node 1:

$$-8 - 3 = \frac{v_1 - v_2}{3} + \frac{v_1 - v_3}{4}$$

or

$$0.5833v_1 - 0.3333v_2 - 0.25v_3 = -11 \quad [7]$$

At node 2:

$$-(-3) = \frac{v_2 - v_1}{3} + \frac{v_2}{1} + \frac{v_2 - v_3}{7}$$

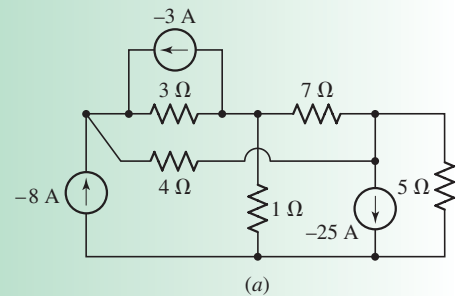

(a)

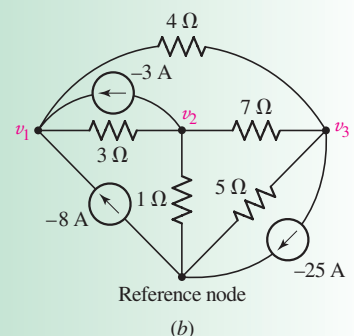

(b)

FIGURE 4.4 (a) A four-node circuit. (b) Redrawn circuit with reference node chosen and voltages labeled.

(Continued on next page)

or

$$-0.3333v_1 + 1.4762v_2 - 0.1429v_3 = 3 \quad [8]$$

And, at node 3:

$$-(-25) = \frac{v_3}{5} + \frac{v_3 - v_2}{7} + \frac{v_3 - v_1}{4}$$

or, more simply,

$$-0.25v_1 - 0.1429v_2 + 0.5929v_3 = 25 \quad [9]$$

► **Determine if additional information is required.**

We have three equations in three unknowns. Provided that they are independent, this is sufficient to determine the three voltages.

► **Attempt a solution.**

Equations [7] through [9] can be solved using a scientific calculator (Appendix 5), software packages such as MATLAB, or more traditional “plug-and-chug” techniques such as elimination of variables, matrix methods, or Cramer’s rule. Using the latter method, described in Appendix 2, we have

$$v_1 = \frac{\begin{vmatrix} -11 & -0.3333 & -0.2500 \\ 3 & 1.4762 & -0.1429 \\ 25 & -0.1429 & 0.5929 \end{vmatrix}}{\begin{vmatrix} 0.5833 & -0.3333 & -0.2500 \\ -0.3333 & 1.4762 & -0.1429 \\ -0.2500 & -0.1429 & 0.5929 \end{vmatrix}} = \frac{1.714}{0.3167} = 5.412 \text{ V}$$

Similarly,

$$v_2 = \frac{\begin{vmatrix} 0.5833 & -11 & -0.2500 \\ -0.3333 & 3 & -0.1429 \\ -0.2500 & 25 & 0.5929 \end{vmatrix}}{0.3167} = \frac{2.450}{0.3167} = 7.736 \text{ V}$$

and

$$v_3 = \frac{\begin{vmatrix} 0.5833 & -0.3333 & -11 \\ -0.3333 & 1.4762 & 3 \\ -0.2500 & -0.1429 & 25 \end{vmatrix}}{0.3167} = \frac{14.67}{0.3167} = 46.32 \text{ V}$$

► **Verify the solution. Is it reasonable or expected?**

Substituting the nodal voltages into any of our three nodal equations is sufficient to ensure we made no computational errors. Beyond that, is it possible to determine whether these voltages are “reasonable” values? We have a maximum possible current of  $3 + 8 + 25 = 36$  amperes anywhere in the circuit. The largest resistor is  $7 \Omega$ , so we do not expect any voltage magnitude greater than  $7 \times 36 = 252 \text{ V}$ .

There are, of course, numerous methods available for the solution of linear systems of equations, and we describe several in Appendix 2 in detail. Prior to the advent of the scientific calculator, Cramer’s rule as seen in Example 4.2 was very common in circuit analysis, although occasionally tedious to implement. It is, however, straightforward to use on a simple

four-function calculator, and so an awareness of the technique can be valuable. MATLAB, on the other hand, although not likely to be available during an examination, is a powerful software package that can greatly simplify the solution process; a brief tutorial on getting started is provided in Appendix 6.

For the situation encountered in Example 4.2, there are several options available through MATLAB. First, we can represent Eqs. [7] to [9] in *matrix form*:

$$\begin{bmatrix} 0.5833 & -0.3333 & -0.25 \\ -0.3333 & 1.4762 & -0.1429 \\ -0.25 & -0.1429 & 0.5929 \end{bmatrix} \begin{bmatrix} v_1 \\ v_2 \\ v_3 \end{bmatrix} = \begin{bmatrix} -11 \\ 3 \\ 25 \end{bmatrix}$$

so that

$$\begin{bmatrix} v_1 \\ v_2 \\ v_3 \end{bmatrix} = \begin{bmatrix} 0.5833 & -0.3333 & -0.25 \\ -0.3333 & 1.4762 & -0.1429 \\ -0.25 & -0.1429 & 0.5929 \end{bmatrix}^{-1} \begin{bmatrix} -11 \\ 3 \\ 25 \end{bmatrix}$$

In MATLAB, we write

```
>> a = [0.5833 -0.3333 -0.25; -0.3333 1.4762 -0.1429; -0.25 -0.1429 0.5929];
>> c = [-11; 3; 25];
>> b = a^-1 * c
b =
    5.4124
    7.7375
   46.3127
>>
```

where spaces separate elements along rows, and a semicolon separates rows. The matrix named **b**, which can also be referred to as a *vector* as it has only one column, is our solution. Thus,  $v_1 = 5.412$  V,  $v_2 = 7.738$  V, and  $v_3 = 46.31$  V (some rounding error has been incurred).

We could also use the KCL equations as we wrote them initially if we employ the symbolic processor of MATLAB.

```
>> eqn1 = '-8 -3 = (v1 - v2)/ 3 + (v1 - v3)/ 4';
>> eqn2 = '-(-3) = (v2 - v1)/ 3 + v2/ 1 + (v2 - v3)/ 7';
>> eqn3 = '-(-25) = v3/ 5 + (v3 - v2)/ 7 + (v3 - v1)/ 4';
>> answer = solve(eqn1, eqn2, eqn3, 'v1', 'v2', 'v3');
>> answer.v1
ans =
    720/133
>> answer.v2
ans =
    147/19
>> answer.v3
ans =
    880/19
>>
```

which results in exact answers, with no rounding errors. The *solve()* routine is invoked with the list of symbolic equations we named eqn1, eqn2, and eqn3, but the variables  $v_1$ ,  $v_2$  and  $v_3$  must also be specified. If *solve()* is called with fewer variables than equations, an algebraic solution is returned. The form of the solution is worth a quick comment; it is returned in what is referred to in programming parlance as a *structure*; in this case, we called our structure “answer.” Each component of the structure is accessed separately by name as shown.

### PRACTICE

4.2 For the circuit of Fig. 4.5, compute the voltage across each current source.

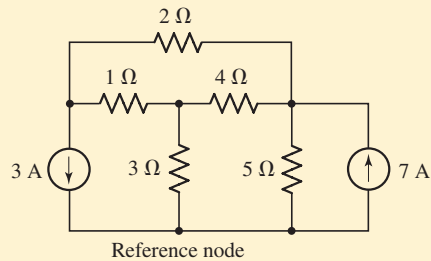

FIGURE 4.5

Ans:  $v_{3A} = 5.235$  V;  $v_{7A} = 11.47$  V.

The previous examples have demonstrated the basic approach to nodal analysis, but it is worth considering what happens if dependent sources are present as well.

### EXAMPLE 4.3

Determine the power supplied by the dependent source of Fig. 4.6a.

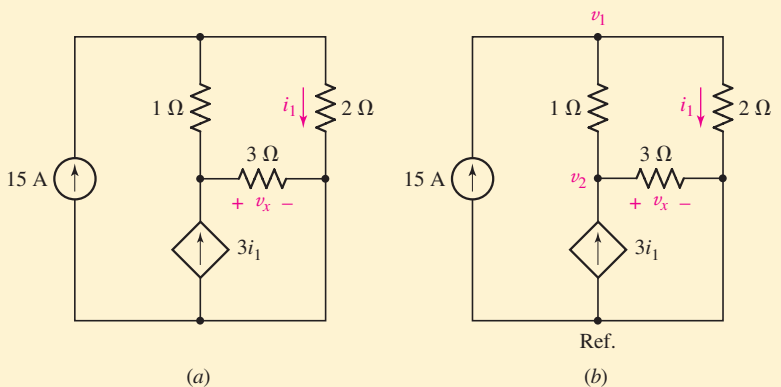

FIGURE 4.6 (a) A four-node circuit containing a dependent current source. (b) Circuit labeled for nodal analysis.



We choose the bottom node as our reference, since it has a large number of branch connections, and proceed to label the nodal voltages  $v_1$  and  $v_2$  as shown in Fig. 4.6b. The quantity labeled  $v_x$  is actually equal to  $v_2$ .

At node 1, we write

$$15 = \frac{v_1 - v_2}{1} + \frac{v_1}{2} \quad [10]$$

and at node 2

$$3i_1 = \frac{v_2 - v_1}{1} + \frac{v_2}{3} \quad [11]$$

Unfortunately, we have only two equations but three unknowns; *this is a direct result of the presence of the dependent current source, since it is not controlled by a nodal voltage*. Thus, we need an additional equation that relates  $i_1$  to one or more nodal voltages.

In this case, we find that

$$i_1 = \frac{v_1}{2} \quad [12]$$

which upon substitution into Eq. [11] yields (with a little rearranging)

$$3v_1 - 2v_2 = 30 \quad [13]$$

and Eq. [10] simplifies to

$$-15v_1 + 8v_2 = 0 \quad [14]$$

Solving, we find that  $v_1 = -40$  V,  $v_2 = -75$  V, and  $i_1 = 0.5v_1 = -20$  A. Thus, the power supplied by the dependent source is equal to  $(3i_1)(v_2) = (-60)(-75) = 4.5$  kW.

We see that the presence of a dependent source will create the need for an additional equation in our analysis if the controlling quantity is not a nodal voltage. Now let's look at the same circuit, but with the controlling variable of the dependent current source changed to a different quantity—the voltage across the  $3\ \Omega$  resistor, which is in fact a nodal voltage. We will find that only *two* equations are required to complete the analysis.



## EXAMPLE 4.4

### Determine the power supplied by the dependent source of Fig. 4.7a.

We select the bottom node as our reference and label the nodal voltages as shown in Fig. 4.7b. We have labeled the nodal voltage  $v_x$  explicitly for clarity. Note that our choice of reference node is important in this case; it led to the quantity  $v_x$  being a nodal voltage.

Our KCL equation for node 1 is

$$15 = \frac{v_1 - v_x}{1} + \frac{v_1}{2} \quad [15]$$

(Continued on next page)

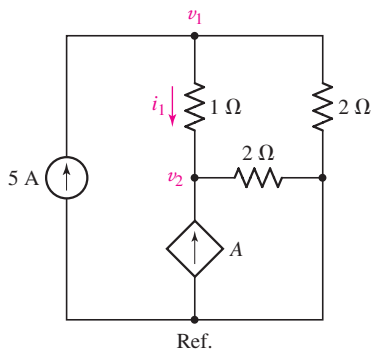

■ FIGURE 4.8

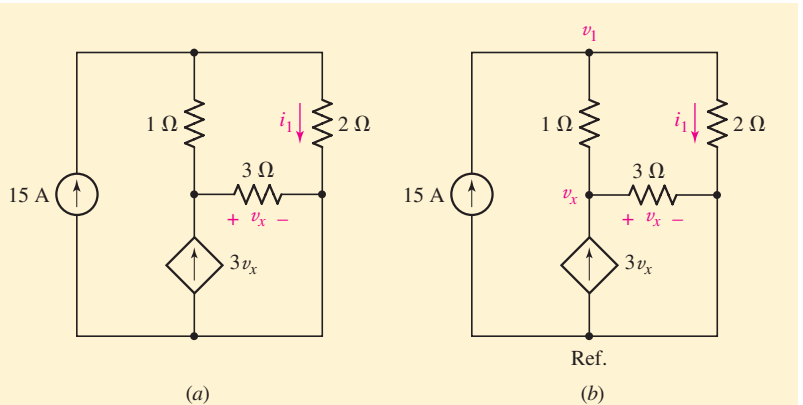

■ FIGURE 4.7 (a) A four-node circuit containing a dependent current source. (b) Circuit labeled for nodal analysis.

and for node  $x$  is

$$3v_x = \frac{v_x - v_1}{1} + \frac{v_2}{3} \quad [16]$$

Grouping terms and solving, we find that  $v_1 = \frac{50}{7}$  V and  $v_x = -\frac{30}{7}$  V. Thus, the dependent source in this circuit generates  $(3v_x)(v_x) = 55.1$  W.

### PRACTICE

4.3 For the circuit of Fig. 4.8, determine the nodal voltage  $v_1$  if  $A$  is (a)  $2i_1$ ; (b)  $2v_1$ .

Ans: (a)  $\frac{70}{9}$  V; (b)  $-10$  V.

### Summary of Basic Nodal Analysis Procedure

1. **Count the number of nodes ( $N$ ).**
2. **Designate a reference node.** The number of terms in your nodal equations can be minimized by selecting the node with the greatest number of branches connected to it.
3. **Label the nodal voltages** (there are  $N - 1$  of them).
4. **Write a KCL equation for each of the nonreference nodes.** Sum the currents flowing *into* a node from sources on one side of the equation. On the other side, sum the currents flowing *out of* the node through resistors. Pay close attention to “ $-$ ” signs.
5. **Express any additional unknowns such as currents or voltages other than nodal voltages in terms of appropriate nodal voltages.** This situation can occur if voltage sources or dependent sources appear in our circuit.
6. **Organize the equations.** Group terms according to nodal voltages.
7. **Solve the system of equations for the nodal voltages** (there will be  $N - 1$  of them).

These seven basic steps will work on any circuit we ever encounter, although the presence of voltage sources will require extra care. Such situations are discussed next.

## 4.2 THE SUPERNODE

As an example of how voltage sources are best handled when performing nodal analysis, consider the circuit shown in Fig. 4.9a. The original four-node circuit of Fig. 4.4 has been changed by replacing the  $7\ \Omega$  resistor between nodes 2 and 3 with a  $22\ \text{V}$  voltage source. We still assign the same node-to-reference voltages  $v_1$ ,  $v_2$ , and  $v_3$ . Previously, the next step was the application of KCL at each of the three nonreference nodes. If we try to do that once again, we see that we will run into some difficulty at both nodes 2 and 3, for we do not know what the current is in the branch with the voltage source. There is no way by which we can express the current as a function of the voltage, for the definition of a voltage source is exactly that the voltage is independent of the current.

There are two ways out of this dilemma. The more difficult approach is to assign an unknown current to the branch which contains the voltage source, proceed to apply KCL three times, and then apply KVL ( $v_3 - v_2 = 22$ ) once between nodes 2 and 3; the result is then four equations in four unknowns.

The easier method is to treat node 2, node 3, and the voltage source together as a sort of *supernode* and apply KCL to both nodes at the same time; the supernode is indicated by the region enclosed by the broken line in Fig. 4.9a. This is okay because if the total current leaving node 2 is zero and the total current leaving node 3 is zero, then the total current leaving the combination of the two nodes is zero. This concept is represented graphically in the expanded view of Fig. 4.9b.

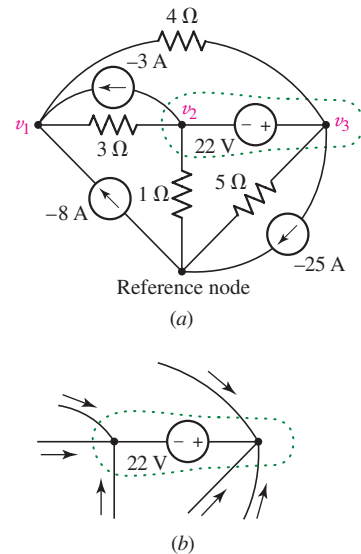

FIGURE 4.9 (a) The circuit of Example 4.2 with a  $22\ \text{V}$  source in place of the  $7\ \Omega$  resistor. (b) Expanded view of the region defined as a supernode; KCL requires that all currents flowing into the region sum to zero, or we would pile up or run out of electrons.

### EXAMPLE 4.5

Determine the value of the unknown node voltage  $v_1$  in the circuit of Fig. 4.9a.

The KCL equation at node 1 is unchanged from Example 4.2:

$$-8 - 3 = \frac{v_1 - v_2}{3} + \frac{v_1 - v_3}{4}$$

or

$$0.5833v_1 - 0.3333v_2 - 0.2500v_3 = -11 \quad [17]$$

Next we consider the 2-3 supernode. Two current sources are connected, and four resistors. Thus,

$$3 + 25 = \frac{v_2 - v_1}{3} + \frac{v_3 - v_1}{4} + \frac{v_3}{5} + \frac{v_2}{1}$$

or

$$-0.5833v_1 + 1.3333v_2 + 0.45v_3 = 28 \quad [18]$$

(Continued on next page)

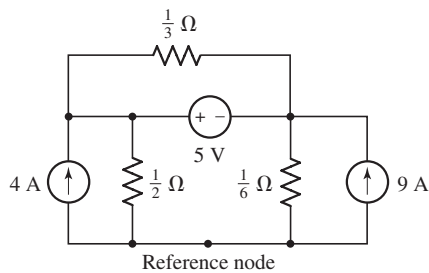

■ FIGURE 4.10



Since we have three unknowns, we need one additional equation, and it must utilize the fact that there is a 22 V voltage source between nodes 2 and 3:

$$v_2 - v_3 = -22 \quad [19]$$

Solving Eqs. [17] to [19], the solution for  $v_1$  is 1.071 V.

### PRACTICE

4.4 For the circuit of Fig. 4.10, compute the voltage across each current source.

Ans: 5.375 V, 375 mV.

The presence of a voltage source thus reduces by 1 the number of nonreference nodes at which we must apply KCL, regardless of whether the voltage source extends between two nonreference nodes or is connected between a node and the reference. We should be careful in analyzing circuits such as that of Practice Problem 4.4. Since both ends of the resistor are part of the supernode, there must technically be *two* corresponding current terms in the KCL equation, but they cancel each other out. We can summarize the supernode method as follows:

### Summary of Supernode Analysis Procedure

1. **Count the number of nodes ( $N$ ).**
2. **Designate a reference node.** The number of terms in your nodal equations can be minimized by selecting the node with the greatest number of branches connected to it.
3. **Label the nodal voltages** (there are  $N - 1$  of them).
4. **If the circuit contains voltage sources, form a supernode about each one.** This is done by enclosing the source, its two terminals, and any other elements connected between the two terminals within a broken-line enclosure.
5. **Write a KCL equation for each nonreference node and for each supernode that does not contain the reference node.** Sum the currents flowing *into* a node/supernode from current sources on one side of the equation. On the other side, sum the currents flowing *out* of the node/supernode through resistors. Pay close attention to “-” signs.
6. **Relate the voltage across each voltage source to nodal voltages.** This is accomplished by simple application of KVL; one such equation is needed for each supernode defined.
7. **Express any additional unknowns (i.e., currents or voltages other than nodal voltages) in terms of appropriate nodal voltages.** This situation can occur if dependent sources appear in our circuit.
8. **Organize the equations.** Group terms according to nodal voltages.
9. **Solve the system of equations for the nodal voltages** (there will be  $N - 1$  of them).

We see that we have added two additional steps from our general nodal analysis procedure. In reality, however, application of the supernode technique to a circuit containing voltage sources not connected to the reference node will result in a reduction in the number of KCL equations required. With this in mind, let's consider the circuit of Fig. 4.11, which contains all four types of sources and has five nodes.

## EXAMPLE 4.6

**Determine the node-to-reference voltages in the circuit of Fig. 4.11.**

After establishing a supernode about each *voltage* source, we see that we need to write KCL equations only at node 2 and at the supernode containing the dependent voltage source. By inspection, it is clear that  $v_1 = -12$  V.

At node 2,

$$\frac{v_2 - v_1}{0.5} + \frac{v_2 - v_3}{2} = 14 \quad [20]$$

while at the 3-4 supernode,

$$0.5v_x = \frac{v_3 - v_2}{2} + \frac{v_4}{1} + \frac{v_4 - v_1}{2.5} \quad [21]$$

We next relate the source voltages to the node voltages:

$$v_3 - v_4 = 0.2v_y \quad [22]$$

and

$$0.2v_y = 0.2(v_4 - v_1) \quad [23]$$

Finally, we express the dependent current source in terms of the assigned variables:

$$0.5v_x = 0.5(v_2 - v_1) \quad [24]$$

Five nodes requires *four* KCL equations in general nodal analysis, but we have reduced this requirement to *only two*, as we formed two separate supernodes. Each supernode required a KVL equation (Eq. [22] and  $v_1 = -12$ , the latter written by inspection). Neither dependent source was controlled by a nodal voltage, so two additional equations were needed as a result.

With this done, we can now eliminate  $v_x$  and  $v_y$  to obtain a set of four equations in the four node voltages:

$$\begin{aligned} -2v_1 + 2.5v_2 - 0.5v_3 &= 14 \\ 0.1v_1 - v_2 + 0.5v_3 + 1.4v_4 &= 0 \\ v_1 &= -12 \\ 0.2v_1 + v_3 - 1.2v_4 &= 0 \end{aligned}$$

Solving,  $v_1 = -12$  V,  $v_2 = -4$  V,  $v_3 = 0$  V, and  $v_4 = -2$  V.

## PRACTICE

4.5 Determine the nodal voltages in the circuit of Fig. 4.12.

Ans:  $v_1 = 3$  V,  $v_2 = -2.33$  V,  $v_3 = -1.91$  V,  $v_4 = 0.945$  V.

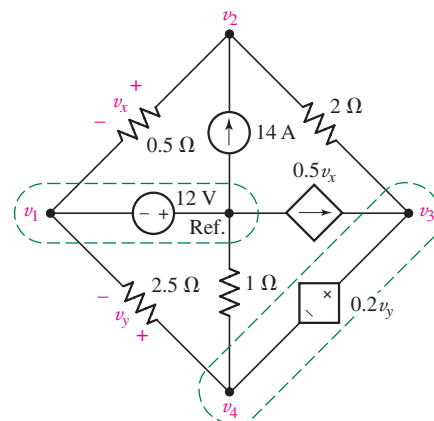

FIGURE 4.11 A five-node circuit with four different types of sources.

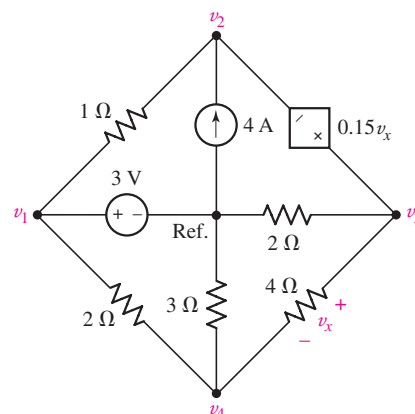
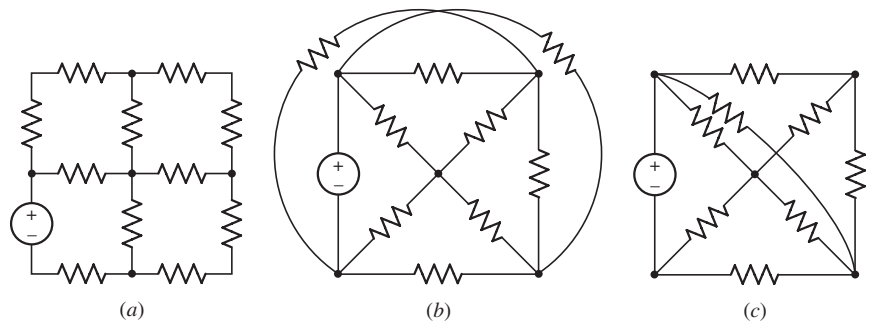

FIGURE 4.12

### 4.3 MESH ANALYSIS

As we have seen, nodal analysis is a straightforward analysis technique when only current sources are present, and voltage sources are easily accommodated with the supernode concept. Still, nodal analysis is based on KCL, and the reader might at some point wonder if there isn't a similar approach based on KVL. There is—it's known as *mesh analysis*—and although only strictly speaking applicable to what we will shortly define as a planar circuit, it can in many cases prove simpler to apply than nodal analysis.

If it is possible to draw the diagram of a circuit on a plane surface in such a way that no branch passes over or under any other branch, then that circuit is said to be a *planar circuit*. Thus, Fig. 4.13a shows a planar network, Fig. 4.13b shows a nonplanar network, and Fig. 4.13c also shows a planar network, although it is drawn in such a way as to make it appear nonplanar at first glance.



■ FIGURE 4.13 Examples of planar and nonplanar networks; crossed wires without a solid dot are not in physical contact with each other.

In Sec. 3.1, the terms *path*, *closed path*, and *loop* were defined. Before we define a mesh, let us consider the sets of branches drawn with heavy lines in Fig. 4.14. The first set of branches is not a path, since four branches are connected to the center node, and it is of course also not a loop. The second set of branches does not constitute a path, since it is traversed only by passing through the central node twice. The remaining four paths are all loops. The circuit contains 11 branches.

The mesh is a property of a planar circuit and is undefined for a nonplanar circuit. We define a *mesh* as a loop that does not contain any other loops within it. Thus, the loops indicated in Fig. 4.14c and d are not meshes, whereas those of parts e and f are meshes. Once a circuit has been drawn neatly in planar form, it often has the appearance of a multipaned window; the boundary of each pane in the window may be considered to be a mesh.

If a network is planar, mesh analysis can be used to accomplish the analysis. This technique involves the concept of a *mesh current*, which we introduce by considering the analysis of the two-mesh circuit of Fig. 4.15a.

As we did in the single-loop circuit, we will begin by defining a current through one of the branches. Let us call the current flowing to the right through the  $6\ \Omega$  resistor  $i_1$ . We will apply KVL around each of the two meshes, and the two resulting equations are sufficient to determine two unknown currents. We next define a second current  $i_2$  flowing to the right in

We should mention that mesh-type analysis can be applied to nonplanar circuits, but since it is not possible to define a complete set of unique meshes for such circuits, assignment of unique mesh currents is not possible.

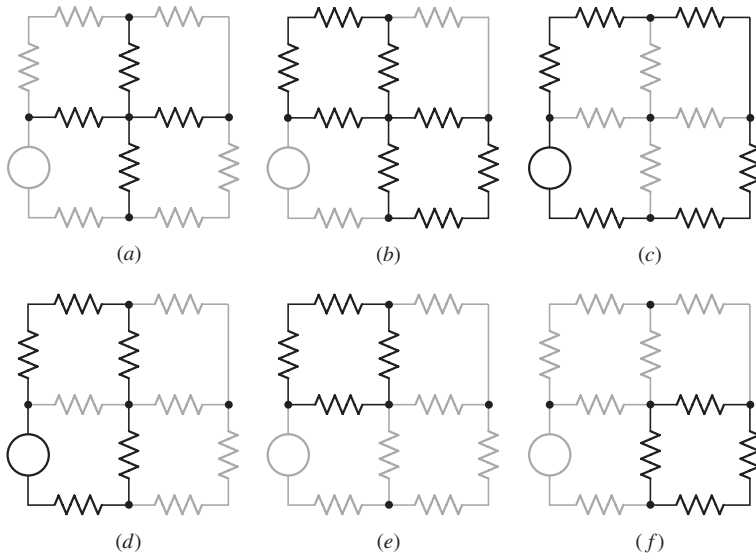

■ FIGURE 4.14 (a) The set of branches identified by the heavy lines is neither a path nor a loop. (b) The set of branches here is not a path, since it can be traversed only by passing through the central node twice. (c) This path is a loop but not a mesh, since it encloses other loops. (d) This path is also a loop but not a mesh. (e, f) Each of these paths is both a loop and a mesh.

the  $4\ \Omega$  resistor. We might also choose to call the current flowing downward through the central branch  $i_3$ , but it is evident from KCL that  $i_3$  may be expressed in terms of the two previously assumed currents as  $(i_1 - i_2)$ . The assumed currents are shown in Fig. 4.15b.

Following the method of solution for the single-loop circuit, we now apply KVL to the left-hand mesh,

$$-42 + 6i_1 + 3(i_1 - i_2) = 0$$

or

$$9i_1 - 3i_2 = 42 \quad [25]$$

Applying KVL to the right-hand mesh,

$$-3(i_1 - i_2) + 4i_2 - 10 = 0$$

or

$$-3i_1 + 7i_2 = 10 \quad [26]$$

Equations [25] and [26] are independent equations; one cannot be derived from the other. With two equations and two unknowns, the solution is easily obtained:

$$i_1 = 6\ \text{A} \quad i_2 = 4\ \text{A} \quad \text{and} \quad (i_1 - i_2) = 2\ \text{A}$$

If our circuit contains  $M$  meshes, then we expect to have  $M$  mesh currents and therefore will be required to write  $M$  independent equations.

Now let us consider this same problem in a slightly different manner by using mesh currents. We define a **mesh current** as a current that flows only around the perimeter of a mesh. One of the greatest advantages in the use of mesh currents is the fact that Kirchhoff's current law is automatically satisfied. If a mesh current flows *into* a given node, it flows *out* of it also.

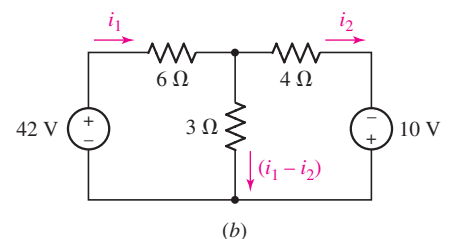
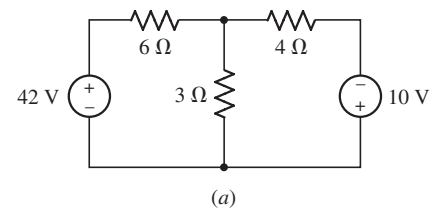

■ FIGURE 4.15 (a, b) A simple circuit for which currents are required.



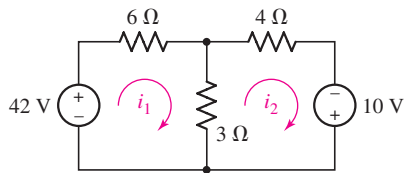

■ FIGURE 4.16 The same circuit considered in Fig. 4.15b, but viewed a slightly different way.

A mesh current may often be identified as a branch current, as  $i_1$  and  $i_2$  have been identified in this example. This is not always true, however, for consideration of a square nine-mesh network soon shows that the central mesh current cannot be identified as the current in any branch.

If we call the left-hand mesh of our problem mesh 1, then we may establish a mesh current  $i_1$  flowing in a clockwise direction about this mesh. A mesh current is indicated by a curved arrow that almost closes on itself and is drawn inside the appropriate mesh, as shown in Fig. 4.16. The mesh current  $i_2$  is established in the remaining mesh, again in a clockwise direction. Although the directions are arbitrary, we will always choose clockwise mesh currents because a certain error-minimizing symmetry then results in the equations.

We no longer have a current or current arrow shown directly on each branch in the circuit. The current through any branch must be determined by considering the mesh currents flowing in every mesh in which that branch appears. This is not difficult, because no branch can appear in more than two meshes. For example, the  $3\ \Omega$  resistor appears in both meshes, and the current flowing downward through it is  $i_1 - i_2$ . The  $6\ \Omega$  resistor appears only in mesh 1, and the current flowing to the right in that branch is equal to the mesh current  $i_1$ .

For the left-hand mesh,

$$-42 + 6i_1 + 3(i_1 - i_2) = 0$$

while for the right-hand mesh,

$$3(i_2 - i_1) + 4i_2 - 10 = 0$$

and these two equations are equivalent to Eqs. [25] and [26].

## EXAMPLE 4.7

Determine the power supplied by the 2 V source of Fig. 4.17a.

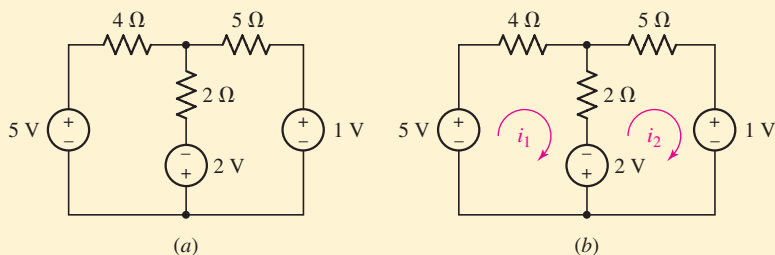

■ FIGURE 4.17 (a) A two-mesh circuit containing three sources. (b) Circuit labeled for mesh analysis.

We first define two clockwise mesh currents as shown in Fig. 4.17b.

Beginning at the bottom left node of mesh 1, we write the following KVL equation as we proceed clockwise through the branches:

$$-5 + 4i_1 + 2(i_1 - i_2) - 2 = 0$$

Doing the same for mesh 2, we write

$$+2 + 2(i_2 - i_1) + 5i_2 + 1 = 0$$



Rearranging and grouping terms,

$$6i_1 - 2i_2 = 7$$

and

$$-2i_1 + 7i_2 = -3$$

Solving,  $i_1 = \frac{43}{38} = 1.132$  A and  $i_2 = -\frac{2}{19} = -0.1053$  A.

The current flowing out of the positive reference terminal of the 2 V source is  $i_1 - i_2$ . Thus, the 2 V source supplies  $(2)(1.237) = 2.474$  W.

### PRACTICE

4.6 Determine  $i_1$  and  $i_2$  in the circuit in Fig. 4.18.

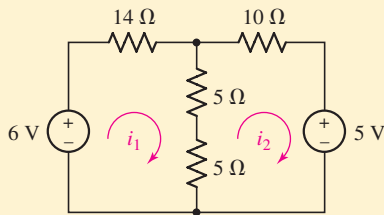

FIGURE 4.18

Ans: +184.2 mA; -157.9 mA.

Let us next consider the five-node, seven-branch, three-mesh circuit shown in Fig. 4.19. This is a slightly more complicated problem because of the additional mesh.

### EXAMPLE 4.8

Use mesh analysis to determine the three mesh currents in the circuit of Fig. 4.19.

The three required mesh currents are assigned as indicated in Fig. 4.19, and we methodically apply KVL about each mesh:

$$-7 + 1(i_1 - i_2) + 6 + 2(i_1 - i_3) = 0$$

$$1(i_2 - i_1) + 2i_2 + 3(i_2 - i_3) = 0$$

$$2(i_3 - i_1) - 6 + 3(i_3 - i_2) + 1i_3 = 0$$

Simplifying,

$$3i_1 - i_2 - 2i_3 = 1$$

$$-i_1 + 6i_2 - 3i_3 = 0$$

$$-2i_1 - 3i_2 + 6i_3 = 6$$

and solving, we obtain  $i_1 = 3$  A,  $i_2 = 2$  A, and  $i_3 = 3$  A.

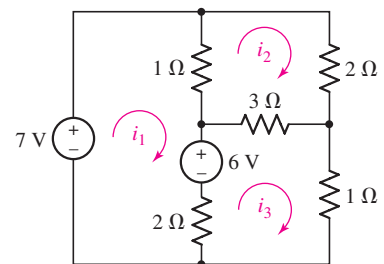

FIGURE 4.19 A five-node, seven-branch, three-mesh circuit.

## PRACTICE

4.7 Determine  $i_1$  and  $i_2$  in the circuit of Fig 4.20.

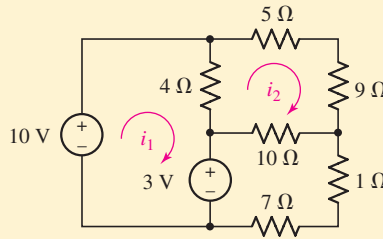
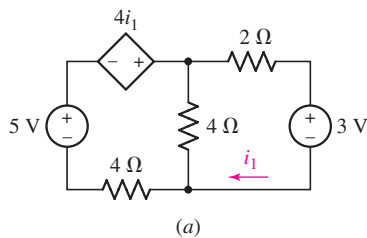

FIGURE 4.20

Ans: 2.220 A, 470.0 mA.

The previous examples dealt with circuits powered exclusively by independent voltage sources. If a current source is included in the circuit, it may either simplify or complicate the analysis, as discussed in Sec. 4.4. As seen in our study of the nodal analysis technique, dependent sources generally require an additional equation besides the  $M$  mesh equations, unless the controlling variable is a mesh current (or sum of mesh currents). We explore this in the following example.

## EXAMPLE 4.9



(a)

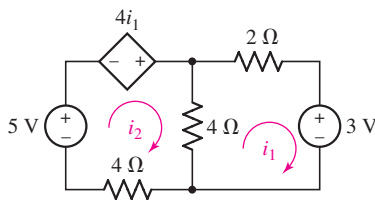

(b)

FIGURE 4.21 (a) A two-mesh circuit containing a dependent source. (b) Circuit labeled for mesh analysis.

Determine the current  $i_1$  in the circuit of Fig. 4.21a.

The current  $i_1$  is actually a mesh current, so rather than redefine it we label the rightmost mesh current  $i_1$  and define a clockwise mesh current  $i_2$  for the left mesh, as shown in Fig. 4.21b.

For the left mesh, KVL yields

$$-5 - 4i_1 + 4(i_2 - i_1) + 4i_2 = 0 \quad [27]$$

and for the right mesh we find

$$4(i_1 - i_2) + 2i_1 + 3 = 0 \quad [28]$$

Grouping terms, these equations may be written more compactly as

$$-8i_1 + 8i_2 = 5$$

and

$$6i_1 - 4i_2 = -3$$

Solving,  $i_2 = 375$  mA, so  $i_1 = -250$  mA.

Since the dependent source of Fig. 4.21 is controlled by a mesh current ( $i_1$ ), only two equations—Eqs. [27] and [28]—were required to analyze the two-mesh circuit. In the following example, we explore the situation that arises if the controlling variable is *not* a mesh current.

## EXAMPLE 4.10

Determine the current  $i_1$  in the circuit of Fig. 4.22a.

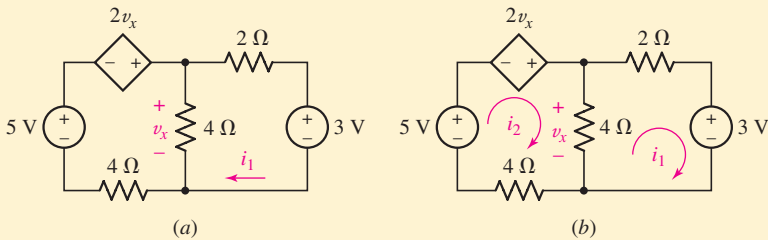

FIGURE 4.22 (a) A circuit with a dependent source controlled by a voltage. (b) Circuit labeled for mesh analysis.

In order to draw comparisons to Example 4.9 we use the same mesh current definitions, as shown in Fig. 4.22b.

For the left mesh, KVL now yields

$$-5 - 2v_x + 4(i_2 - i_1) + 4i_2 = 0 \quad [29]$$

and for the right mesh we find the same as before, namely,

$$4(i_1 - i_2) + 2i_1 + 3 = 0 \quad [30]$$

Since the dependent source is controlled by the unknown voltage  $v_x$ , we are faced with *two* equations in *three* unknowns. The way out of our dilemma is to construct an equation for  $v_x$  in terms of mesh currents, such as

$$v_x = 4(i_2 - i_1) \quad [31]$$

We simplify our system of equations by substituting Eq. [31] into Eq. [29], resulting in

$$4i_1 = 5$$

Solving, we find that  $i_1 = 1.25$  A. In this particular instance, Eq. [30] is not needed unless a value for  $i_2$  is desired.

## PRACTICE

4.8 Determine  $i_1$  in the circuit of Fig. 4.23 if the controlling quantity  $A$  is equal to (a)  $2i_2$ ; (b)  $2v_x$ .

Ans: (a) 1.35 A; (b) 546 mA.

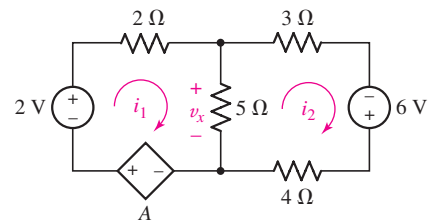

FIGURE 4.23

The mesh analysis procedure can be summarized by the seven basic steps that follow. It will work on any *planar* circuit we ever encounter, although the presence of current sources will require extra care. Such situations are discussed in Sec. 4.4.

### Summary of Basic Mesh Analysis Procedure

1. **Determine if the circuit is a planar circuit.** If not, perform nodal analysis instead.
2. **Count the number of meshes ( $M$ ).** Redraw the circuit if necessary.
3. **Label each of the  $M$  mesh currents.** Generally, defining all mesh currents to flow clockwise results in a simpler analysis.
4. **Write a KVL equation around each mesh.** Begin with a convenient node and proceed in the direction of the mesh current. Pay close attention to “−” signs. If a current source lies on the periphery of a mesh, no KVL equation is needed and the mesh current is determined by inspection.
5. **Express any additional unknowns such as voltages or currents other than mesh currents in terms of appropriate mesh currents.** This situation can occur if current sources or dependent sources appear in our circuit.
6. **Organize the equations.** Group terms according to mesh currents.
7. **Solve the system of equations for the mesh currents** (there will be  $M$  of them).

## 4.4 THE SUPERMESH

How must we modify this straightforward procedure when a current source is present in the network? Taking our lead from nodal analysis, we should feel that there are two possible methods. First, we could assign an unknown voltage across the current source, apply KVL around each mesh as before, and then relate the source current to the assigned mesh currents. This is generally the more difficult approach.

A better technique is one that is quite similar to the supernode approach in nodal analysis. There we formed a supernode, completely enclosing the voltage source inside the supernode and reducing the number of non-reference nodes by 1 for each voltage source. Now we create a kind of “*supermesh*” from two meshes that have a current source as a common element; the current source is in the interior of the supermesh. We thus reduce the number of meshes by 1 for each current source present. If the current source lies on the *perimeter* of the circuit, then the single mesh in which it is found is ignored. Kirchhoff’s voltage law is thus applied only to those meshes or supermeshes in the reinterpreted network.

### EXAMPLE 4.11

#### Determine the three mesh currents in Fig. 4.24a.

We note that a 7 A independent current source is in the common boundary of two meshes, which leads us to create a supermesh whose interior

is that of meshes 1 and 3 as shown in Fig. 4.24b. Applying KVL about this loop,

$$-7 + 1(i_1 - i_2) + 3(i_3 - i_2) + 1i_3 = 0$$

or

$$i_1 - 4i_2 + 4i_3 = 7 \quad [32]$$

and around mesh 2,

$$1(i_2 - i_1) + 2i_2 + 3(i_2 - i_3) = 0$$

or

$$-i_1 + 6i_2 - 3i_3 = 0 \quad [33]$$

Finally, the independent source current is related to the mesh currents,

$$i_1 - i_3 = 7 \quad [34]$$

Solving Eqs. [32] through [34], we find  $i_1 = 9$  A,  $i_2 = 2.5$  A, and  $i_3 = 2$  A.

### PRACTICE

4.9 Determine the current  $i_1$  in the circuit of Fig. 4.25.

Ans:  $-1.93$  A.

The presence of one or more dependent sources merely requires each of these source quantities and the variable on which it depends to be expressed in terms of the assigned mesh currents. In Fig. 4.26, for example, we note that both a dependent and an independent current source are included in the network. Let's see how their presence affects the analysis of the circuit and actually simplifies it.

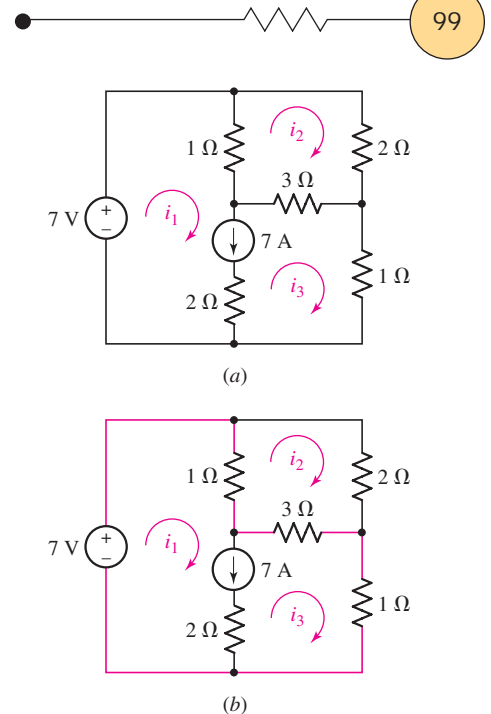

FIGURE 4.24 (a) A three-mesh circuit with an independent current source. (b) A supermesh is defined by the colored line.

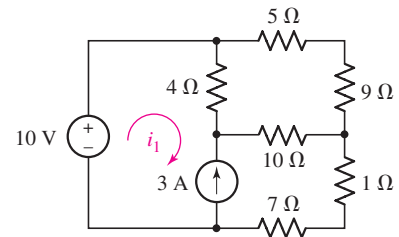

FIGURE 4.25

### EXAMPLE 4.12

Evaluate the three unknown currents in the circuit of Fig. 4.26.

The current sources appear in meshes 1 and 3. Since the 15 A source is located on the perimeter of the circuit, we may eliminate mesh 1 from consideration—it is clear that  $i_1 = 15$  A.

We find that because we now know one of the two mesh currents relevant to the dependent current source, there is no need to write a supermesh equation about meshes 1 and 3. Instead, we simply relate  $i_1$  and  $i_3$  to the current from the dependent source using KCL:

$$\frac{v_x}{9} = i_3 - i_1 = \frac{3(i_3 - i_2)}{9}$$

(Continued on next page)

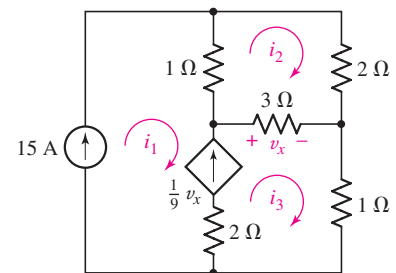

FIGURE 4.26 A three-mesh circuit with one dependent and one independent current source.

which can be written more compactly as

$$-i_1 + \frac{1}{3}i_2 + \frac{2}{3}i_3 = 0 \quad \text{or} \quad \frac{1}{3}i_2 + \frac{2}{3}i_3 = 15 \quad [35]$$

With one equation in two unknowns, all that remains is to write a KVL equation about mesh 2:

$$1(i_2 - i_1) + 2i_2 + 3(i_2 - i_3) = 0$$

or

$$6i_2 - 3i_3 = 15 \quad [36]$$

Solving Eqs. [35] and [36], we find that  $i_2 = 11$  A and  $i_3 = 17$  A; we already determined that  $i_1 = 15$  A by inspection.

### PRACTICE

4.10 Determine  $v_3$  in the circuit of Fig. 4.27.

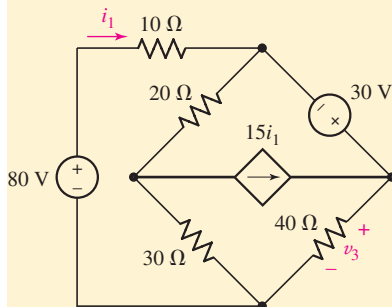

■ FIGURE 4.27

Ans: 104.2 V

We can now summarize the general approach to writing mesh equations, whether or not dependent sources, voltage sources, and/or current sources are present, provided that the circuit can be drawn as a planar circuit:

#### Summary of Supermesh Analysis Procedure

1. **Determine if the circuit is a planar circuit.** If not, perform nodal analysis instead.
2. **Count the number of meshes ( $M$ ).** Redraw the circuit if necessary.
3. **Label each of the  $M$  mesh currents.** Generally, defining all mesh currents to flow clockwise results in a simpler analysis.
4. **If the circuit contains current sources shared by two meshes, form a supermesh to enclose both meshes.** A highlighted enclosure helps when writing KVL equations.
5. **Write a KVL equation around each mesh/supermesh.** Begin with a convenient node and proceed in the direction of the mesh current. Pay close attention to “−” signs. If a current source lies

on the periphery of a mesh, no KVL equation is needed and the mesh current is determined by inspection.

6. **Relate the current flowing from each current source to mesh currents.** This is accomplished by simple application of KCL; one such equation is needed for each supermesh defined.
7. **Express any additional unknowns such as voltages or currents other than mesh currents in terms of appropriate mesh currents.** This situation can occur if dependent sources appear in our circuit.
8. **Organize the equations.** Group terms according to nodal voltages.
9. **Solve the system of equations for the mesh currents** (there will be  $M$  of them).

## 4.5 NODAL VS. MESH ANALYSIS: A COMPARISON

Now that we have examined two distinctly different approaches to circuit analysis, it seems logical to ask if there is ever any advantage to using one over the other. If the circuit is nonplanar, then there is no choice: only nodal analysis may be applied.

Provided that we are indeed considering the analysis of a *planar* circuit, however, there are situations where one technique has a small advantage over the other. If we plan to use nodal analysis, then a circuit with  $N$  nodes will lead to at most  $(N - 1)$  KCL equations. Each supernode defined will further reduce this number by 1. If the same circuit has  $M$  distinct meshes, then we will obtain at most  $M$  KVL equations; each supermesh will reduce this number by 1. Based on these facts, we should select the approach that will result in the smaller number of simultaneous equations.

If one or more dependent sources are included in the circuit, then each controlling quantity may influence our choice of nodal or mesh analysis. For example, a dependent voltage source controlled by a nodal voltage does not require an additional equation when we perform nodal analysis. Likewise, a dependent current source controlled by a mesh current does not require an additional equation when we perform mesh analysis. *What about the situation where a dependent voltage source is controlled by a current? Or the converse, where a dependent current source is controlled by a voltage?* Provided that the controlling quantity can be easily related to mesh currents, we might expect mesh analysis to be the more straightforward option. Likewise, if the controlling quantity can be easily related to nodal voltages, nodal analysis may be preferable. One final point in this regard is to keep in mind the *location* of the source; current sources which lie on the periphery of a mesh, whether dependent or independent, are easily treated in mesh analysis; voltage sources connected to the reference terminal are easily treated in nodal analysis.

When either method results in essentially the same number of equations, it may be worthwhile to also consider what quantities are being sought. Nodal analysis results in direct calculation of nodal voltages, whereas mesh analysis provides currents. If we are asked to find currents through a set of resistors, for example, after performing nodal analysis, we must still invoke Ohm's law at each resistor to determine the current.

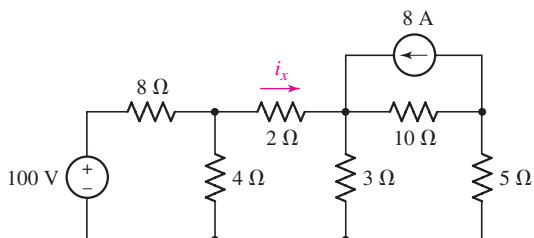

■ FIGURE 4.28 A planar circuit with five nodes and four meshes.

As an example, consider the circuit in Fig. 4.28. We wish to determine the current  $i_x$ .

We choose the bottom node as the reference node, and note that there are four nonreference nodes. Although this means that we can write four distinct equations, there is no need to label the node between the 100 V source and the 8 Ω resistor, since that node voltage is clearly 100 V. Thus, we label the remaining node voltages  $v_1$ ,  $v_2$ , and  $v_3$  as in Fig. 4.29.

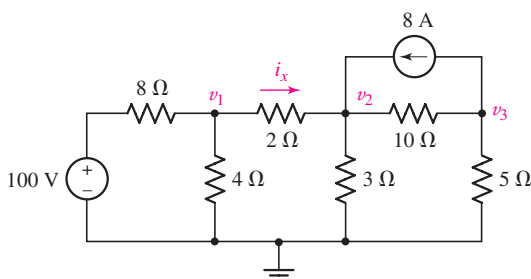

■ FIGURE 4.29 The circuit of Fig. 4.28 with node voltages labeled. Note that an earth ground symbol was chosen to designate the reference terminal.

We write the following three equations:

$$\frac{v_1 - 100}{8} + \frac{v_1}{4} + \frac{v_1 - v_2}{2} = 0 \quad \text{or} \quad 0.875v_1 - 0.5v_2 = 12.5 \quad [37]$$

$$\frac{v_2 - v_1}{2} + \frac{v_2}{3} + \frac{v_2 - v_3}{10} - 8 = 0 \quad \text{or} \quad -0.5v_1 - 0.9333v_2 - 0.1v_3 = 8 \quad [38]$$

$$\frac{v_3 - v_2}{10} + \frac{v_3}{5} + 8 = 0 \quad \text{or} \quad -0.1v_2 + 0.3v_3 = -8 \quad [39]$$

Solving, we find that  $v_1 = 25.89$  V and  $v_2 = 20.31$  V. We determine the current  $i_x$  by application of Ohm's law:

$$i_x = \frac{v_1 - v_2}{2} = 2.79 \text{ A} \quad [40]$$



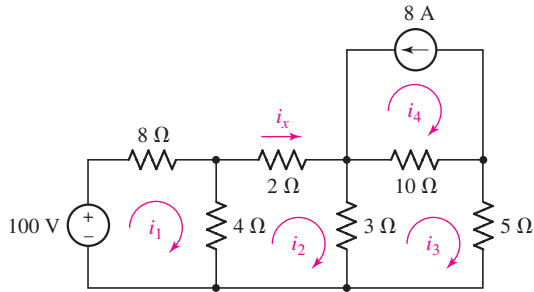

■ FIGURE 4.30 The circuit of Fig. 4.28 with mesh currents labeled.

Next, we consider the same circuit using mesh analysis. We see in Fig. 4.30 that we have four distinct meshes, although it is obvious that  $i_4 = -8$  A; we therefore need to write three distinct equations.

Writing a KVL equation for meshes 1, 2, and 3:

$$-100 + 8i_1 + 4(i_1 - i_2) = 0 \quad \text{or} \quad 12i_1 - 4i_2 = 100 \quad [41]$$

$$4(i_2 - i_1) + 2i_2 + 3(i_2 - i_3) = 0 \quad \text{or} \quad -4i_1 + 9i_2 - 3i_3 = 0 \quad [42]$$

$$3(i_3 - i_2) + 10(i_3 + 8) + 5i_3 = 0 \quad \text{or} \quad -3i_2 + 18i_3 = -80 \quad [43]$$

Solving, we find that  $i_2 (= i_x) = 2.79$  A. For this particular problem, mesh analysis proved to be simpler. Since either method is valid, however, working the same problem both ways can also serve as a means to check our answers.

## 4.6 COMPUTER-AIDED CIRCUIT ANALYSIS

We have seen that it does not take many components at all to create a circuit of respectable complexity. As we continue to examine even more complex circuits, it will become obvious rather quickly that it is easy to make errors during the analysis, and verifying solutions by hand can be time-consuming. A powerful computer software package known as PSpice is commonly employed for rapid analysis of circuits, and the schematic capture tools are typically integrated with either a printed circuit board or integrated circuit layout tool. Originally developed in the early 1970s at the University of California at Berkeley, SPICE (*Simulation Program with Integrated Circuit Emphasis*) is now an industry standard. MicroSim Corporation introduced PSpice in 1984, which built intuitive graphical interfaces around the core SPICE program. Depending on the type of circuit application being considered, there are now several companies offering variations of the basic SPICE package.

Although computer-aided analysis is a relatively quick means of determining voltages and currents in a circuit, we should be careful not to allow simulation packages to completely replace traditional “paper and pencil” analysis. There are several reasons for this. First, in order to design we must be able to analyze. Overreliance on software tools can inhibit the development of necessary analytical skills, similar to introducing calculators too early in grade school. Second, it is virtually impossible to use a complicated software package over a long period of time without making some type of data-entry error. If we have no basic intuition as to what type of answer to



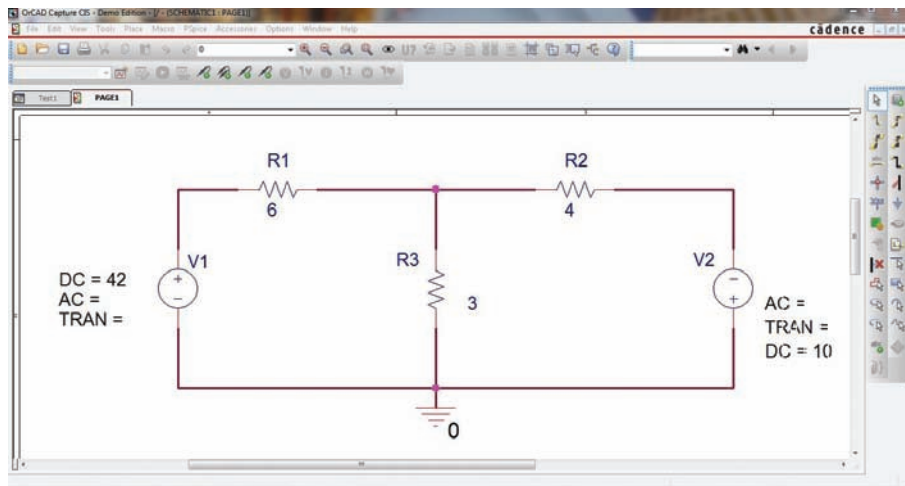

(a)



(b)

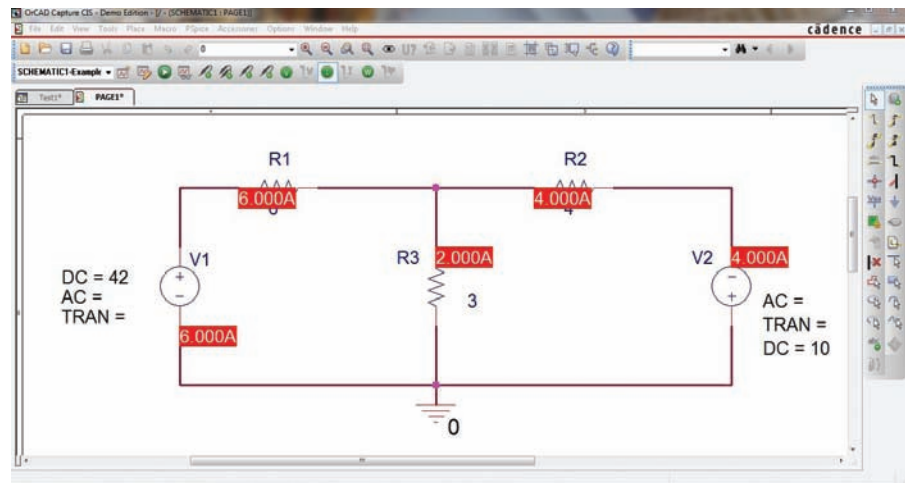

(c)

■ FIGURE 4.31 (a) Circuit of Fig. 4.15a drawn using OrCAD schematic capture software. (b) Current, voltage, and power display buttons. (c) Circuit after simulation run, with current display enabled.

expect from a simulation, then there is no way to determine whether or not it is valid. Thus, the generic name really is a fairly accurate description: *computer-aided analysis*. Human brains are not obsolete. Not yet, anyway.

As an example, consider the circuit of Fig. 4.15b, which includes two dc voltage sources and three resistors. We wish to simulate this circuit using PSpice so that we may determine the currents  $i_1$  and  $i_2$ . Figure 4.31a shows the circuit as drawn using a schematic capture program.<sup>1</sup>

(1) Refer to Appendix 4 for a brief tutorial on PSpice and schematic capture.

In order to determine the mesh currents, we need only run a bias point simulation. Under **PSpice**, select **New Simulation Profile**, type in a name (such as Example), and click on **Create**. Under the **Analysis type**: pull-down menu, select **Bias Point**, then click on **OK**. Returning to the original schematic window, under **PSpice** select **Run** (or use either of the two shortcuts: pressing the F11 key or clicking on the blue “Play” symbol). To see the currents calculated by PSpice, make sure the current button is selected (Fig. 4.31b). The results of our simulation are shown in Fig. 4.31c. We see that the two currents  $i_1$  and  $i_2$  are 6 A and 4 A, respectively, as we found previously.

As a further example, consider the circuit shown in Fig. 4.32a. It contains a dc voltage source, a dc current source, and a voltage-controlled current source. We are interested in the three nodal voltages, which from either nodal or mesh analysis are found to be 82.91 V, 69.9 V, and 59.9 V, respectively, as we move from left to right across the top of the circuit. Figure 4.32b shows this circuit after the simulation was performed. The three nodal voltages are indicated directly on the schematic. Note that in drawing a dependent source using the schematic capture tool, we must *explicitly* link two terminals of the source to the controlling voltage or current.

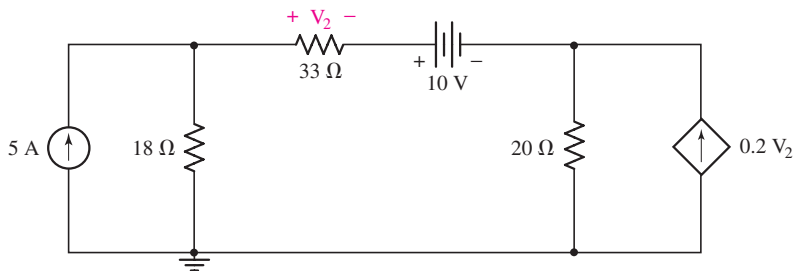

(a)

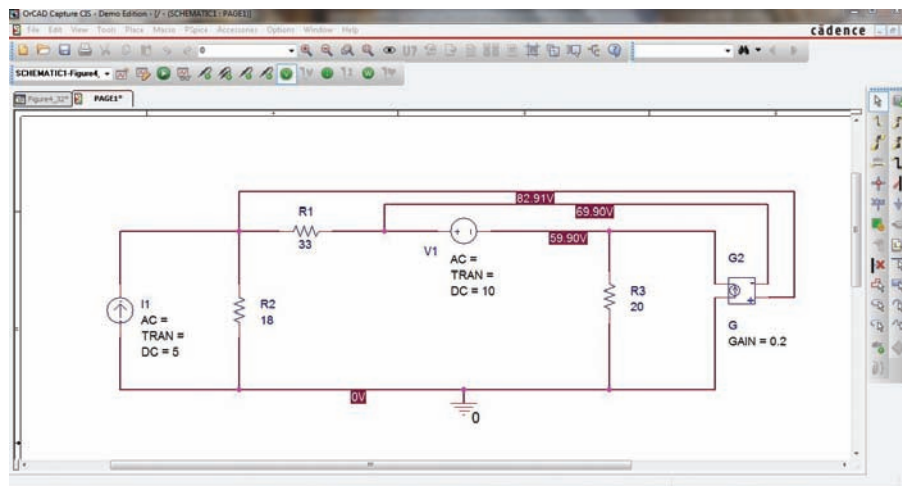

(b)

■ FIGURE 4.32 (a) Circuit with dependent current source. (b) Circuit drawn using a schematic capture tool, with simulation results presented directly on the schematic.

# PRACTICAL APPLICATION

## Node-Based PSpice Schematic Creation

The most common method of describing a circuit in conjunction with computer-aided circuit analysis is with some type of graphical schematic drawing package, an example output of which was shown in Fig. 4.32. SPICE, however, was written before the advent of such software, and as such requires circuits to be described in a specific text-based format. The format has its roots in the syntax used for punch cards, which gives it a somewhat distinct appearance. The basis for circuit description is the definition of elements, each terminal of which is assigned a node number. So, although we have just studied two different generalized circuit analysis methods—the nodal and mesh techniques—it is interesting that SPICE and PSpice were written using a clearly defined nodal analysis approach.

Even though modern circuit analysis is largely done using graphics-oriented interactive software, when errors are generated (usually due to a mistake in drawing the schematic or in selecting a combination of analysis options), the ability to read the text-based “input deck” generated by the schematic capture tool can be invaluable in tracking down the specific problem. The easiest way to develop such an ability is to learn how to run PSpice directly from a user-written input deck.

Consider, for example, the sample input deck below (lines beginning with an asterisk are comments, and are skipped by SPICE).

\* Example SPICE input deck for simple voltage divider circuit.

```
.OP                                (Requests dc operating point)
R1 1 2 1k                          (Locates R1 between nodes 1 and 2; value is 1 kΩ)
R2 2 0 1k                          (Locates R2 between nodes 2 and 0; also 1 kΩ)
V1 1 0 DC 5                        (Locates 5 V source between nodes 1 and 0)
```

\* End of input deck.

We can create the input deck by using the Notepad program from Windows or our favorite text editor. Saving the file under the name `example.cir`, we next invoke PSpice A/D (see Appendix. 4). Under **File**, we choose **Open**, locate the directory in which we saved our file `example.cir`, and for **Files of type**: select **Circuit Files (\*.cir)**. After selecting our file and clicking **Open**, we see the PSpice A/D window with our circuit file loaded (Fig. 4.33a). A netlist such as this, containing instructions for the simulation to be performed, can be created by schematic capture software or created manually as in this example.

We run the simulation by either clicking the green “play” symbol at the top right, or selecting **Run** under **Simulation**.

To view the results, we select **Output File** from under the **View** menu, which provides the window shown in Fig. 4.33b. Here it is worth noting that the output provides the expected nodal voltages (5 V at node 1, 2.5 V across resistor R2), but the current is quoted using the passive sign convention (i.e.,  $-2.5$  mA).

Text-based schematic entry is reasonably straightforward, but for complex (large number of elements) circuits, it can quickly become cumbersome. It is also easy to misnumber nodes, an error that can be difficult to isolate. However, reading the input and output files is often helpful when running simulations, so some experience with this format is useful.

At this point, the real power of computer-aided analysis begins to be apparent: Once you have the circuit drawn in the schematic capture program, it is easy to experiment by simply changing component values and observing the effect on currents and voltages. To gain a little experience at this point, try simulating any of the circuits shown in previous examples and practice problems.

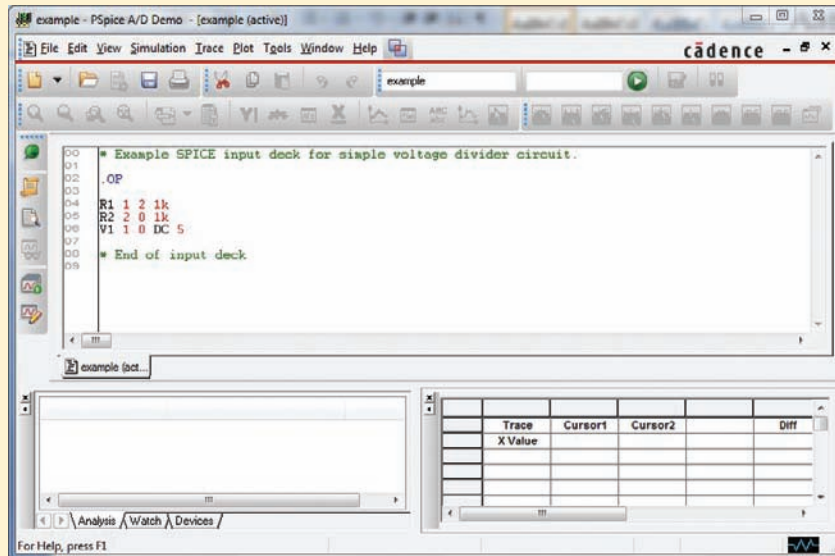

(a)

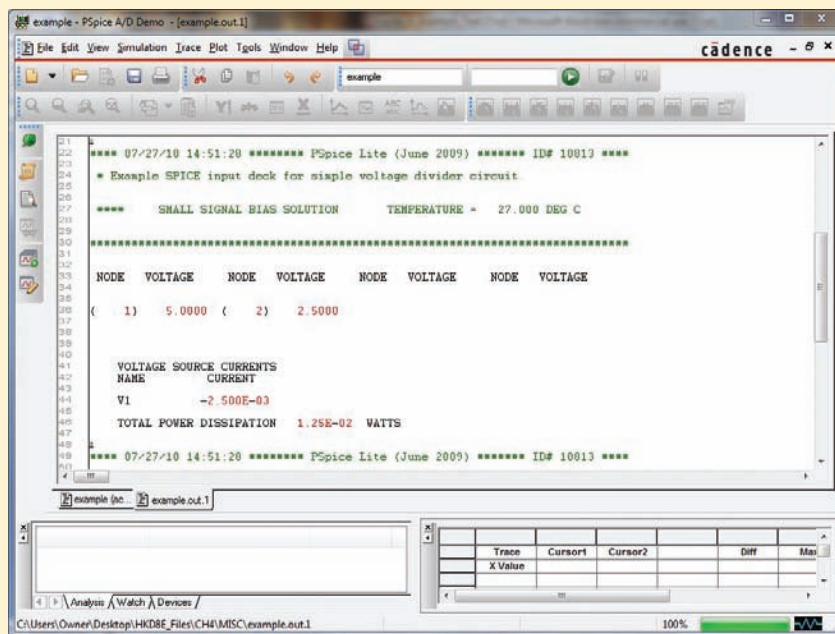

(b)

■ FIGURE 4.33 (a) PSpice A/D window after the input deck describing our voltage divider is loaded. (b) Output window, showing nodal voltages and current from the source (but quoted using the passive sign convention). Note that the voltage across R1 requires post-simulation subtraction.

## SUMMARY AND REVIEW

Although Chap. 3 introduced KCL and KVL, both of which are sufficient to enable us to analyze any circuit, a more methodical approach proves helpful in everyday situations. Thus, in this chapter we developed the nodal analysis technique based on KCL, which results in a voltage at each node

(with respect to some designated “reference” node). We generally need to solve a system of simultaneous equations, unless voltage sources are connected so that they automatically provide nodal voltages. The controlling quantity of a *dependent* source is written down just as we would write down the numerical value of an “independent” source. Typically an additional equation is then required, unless the dependent source is controlled by a nodal voltage. When a voltage source bridges two nodes, the basic technique can be extended by creating a *supernode*; KCL dictates that the sum of the currents flowing into a group of connections so defined is equal to the sum of the currents flowing out.

As an alternative to nodal analysis, the mesh analysis technique was developed through application of KVL; it yields the complete set of *mesh* currents, which do not always represent the *net* current flowing through any particular element (for example, if an element is shared by two meshes). The presence of a current source will simplify the analysis if it lies on the periphery of a mesh; if the source is shared, then the *supermesh* technique is best. In that case, we write a KVL equation around a path that avoids the shared current source, then algebraically link the two corresponding mesh currents using the source.

A common question is: “Which analysis technique should I use?” We discussed some of the issues that might go into choosing a technique for a given circuit. These included whether or not the circuit is planar, what types of sources are present and how they are connected, and also what specific information is required (i.e., a voltage, current, or power). For complex circuits, it may take a greater effort than it is worth to determine the “optimum” approach, in which case most people will opt for the method with which they feel most comfortable. We concluded the chapter by introducing PSpice, a common circuit simulation tool, which is very useful for checking our results.

At this point we wrap up by identifying key points of this chapter to review, along with relevant example(s).

- Start each analysis with a neat, simple circuit diagram. Indicate all element and source values. (Example 4.1)
- For nodal analysis,
  - Choose one node as the reference node. Then label the node voltages  $v_1, v_2, \dots, v_{N-1}$ . Each is understood to be measured with respect to the reference node. (Examples 4.1, 4.2)
  - If the circuit contains only current sources, apply KCL at each nonreference node. (Examples 4.1, 4.2)
  - If the circuit contains voltage sources, form a supernode about each one, and then apply KCL at all nonreference nodes and supernodes. (Examples 4.5, 4.6)
- For mesh analysis, first make certain that the network is a planar network.
  - Assign a clockwise mesh current in each mesh:  $i_1, i_2, \dots, i_M$ . (Example 4.7)
  - If the circuit contains only voltage sources, apply KVL around each mesh. (Examples 4.7, 4.8, 4.9)
  - If the circuit contains current sources, create a supermesh for each one that is common to two meshes, and then apply KVL around each mesh and supermesh. (Examples 4.11, 4.12)

- Dependent sources will add an additional equation to nodal analysis if the controlling variable is a current, but not if the controlling variable is a nodal voltage. (Conversely, a dependent source will add an additional equation to mesh analysis if the controlling variable is a voltage, but not if the controlling variable is a mesh current). (Examples 4.3, 4.4, 4.6, 4.9, 4.10, 4.12)
- In deciding whether to use nodal or mesh analysis for a planar circuit, a circuit with fewer nodes/supernodes than meshes/supermeshes will result in fewer equations using nodal analysis.
- Computer-aided analysis is useful for checking results and analyzing circuits with large numbers of elements. However, common sense must be used to check simulation results.

## READING FURTHER

A detailed treatment of nodal and mesh analysis can be found in:

R. A. DeCarlo and P. M. Lin, *Linear Circuit Analysis*, 2nd ed. New York: Oxford University Press, 2001.

A solid guide to SPICE is

P. Tuinenga, *SPICE: A Guide to Circuit Simulation and Analysis Using PSpice*, 3rd ed. Upper Saddle River, N.J.: Prentice-Hall, 1995.

## EXERCISES

### 4.1 Nodal Analysis

1. Solve the following systems of equations:

(a)  $2v_2 - 4v_1 = 9$  and  $v_1 - 5v_2 = -4$ ;

(b)  $-v_1 + 2v_3 = 8$ ;  $2v_1 + v_2 - 5v_3 = -7$ ;  $4v_1 + 5v_2 + 8v_3 = 6$ .

2. Evaluate the following determinants:

(a)  $\begin{vmatrix} 2 & 1 \\ -4 & 3 \end{vmatrix}$       (b)  $\begin{vmatrix} 0 & 2 & 11 \\ 6 & 4 & 1 \\ 3 & -1 & 5 \end{vmatrix}$ .

3. Employ Cramer's rule to solve for  $v_2$  in each part of Exercise 1.

4. (a) Solve the following system of equations:

$$3 = \frac{v_1}{5} - \frac{v_2 - v_1}{22} + \frac{v_1 - v_3}{3}$$

$$2 - 1 = \frac{v_2 - v_1}{22} + \frac{v_2 - v_3}{14}$$

$$0 = \frac{v_3}{10} + \frac{v_3 - v_1}{3} + \frac{v_3 - v_2}{14}$$

(b) Verify your solution using MATLAB.

5. (a) Solve the following system of equations:

$$7 = \frac{v_1}{2} - \frac{v_2 - v_1}{12} + \frac{v_1 - v_3}{19}$$

$$15 = \frac{v_2 - v_1}{12} + \frac{v_2 - v_3}{2}$$

$$4 = \frac{v_3}{7} + \frac{v_3 - v_1}{19} + \frac{v_3 - v_2}{2}$$

(b) Verify your solution using MATLAB.





6. Correct (and verify by running) the following MATLAB code:

```
>> e1 = '3 = v/7 - (v2 - v1)/2 + (v1 - v3)/3;
>> e2 = '2 = (v2 - v1)/2 + (v2 - v3)/14';
>> e3 = '0 = v3/10 + (v3 - v1)/3 + (v3 - v2)/14';
>>
>> a = solve(e1 e2 e3, 'v1', v2, 'v3')
```

7. Identify the obvious errors in the following complete set of nodal equations if the last equation is known to be correct:

$$7 = \frac{v_1}{4} - \frac{v_2 - v_1}{1} + \frac{v_1 - v_3}{9}$$

$$0 = \frac{v_2 - v_1}{2} + \frac{v_2 - v_3}{2}$$

$$4 = \frac{v_3}{7} + \frac{v_3 - v_1}{19} + \frac{v_3 - v_2}{2}$$

8. In the circuit of Fig. 4.34, determine the current labeled  $i$  with the assistance of nodal analysis techniques.

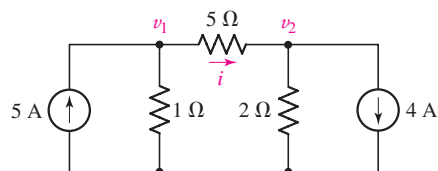

■ FIGURE 4.34

9. Calculate the power dissipated in the 1 Ω resistor of Fig. 4.35.

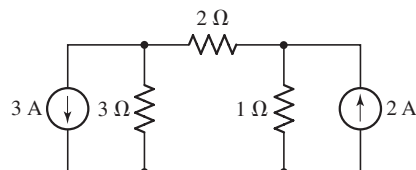

■ FIGURE 4.35

10. With the assistance of nodal analysis, determine  $v_1 - v_2$  in the circuit shown in Fig. 4.36.

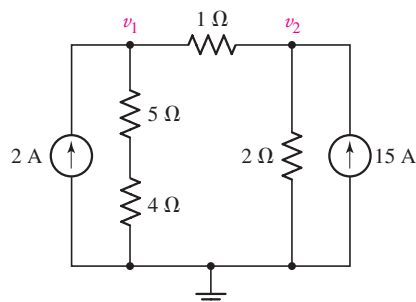

■ FIGURE 4.36



11. For the circuit of Fig. 4.37, determine the value of the voltage labeled  $v_1$  and the current labeled  $i_1$ .

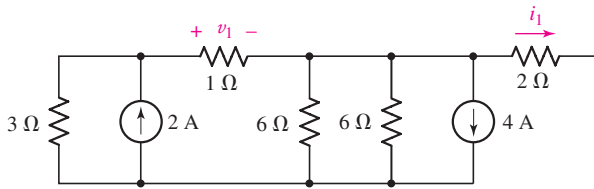

■ FIGURE 4.37

12. Use nodal analysis to find  $v_P$  in the circuit shown in Fig. 4.38.

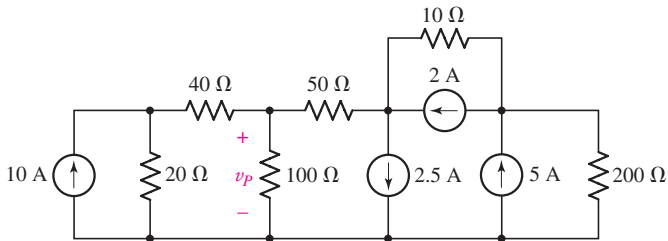

■ FIGURE 4.38

13. Using the bottom node as reference, determine the voltage across the  $5 \Omega$  resistor in the circuit of Fig. 4.39, and calculate the power dissipated by the  $7 \Omega$  resistor.

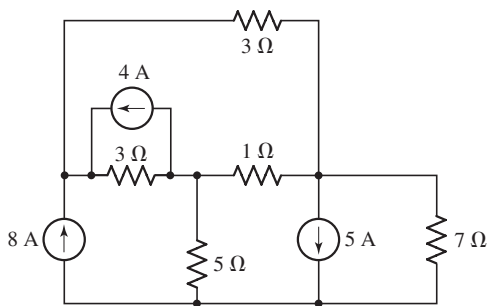

■ FIGURE 4.39

14. For the circuit of Fig. 4.40, use nodal analysis to determine the current  $i_5$ .

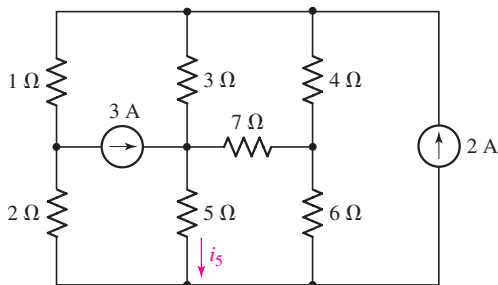

■ FIGURE 4.40

15. Determine a numerical value for each nodal voltage in the circuit of Fig. 4.41.

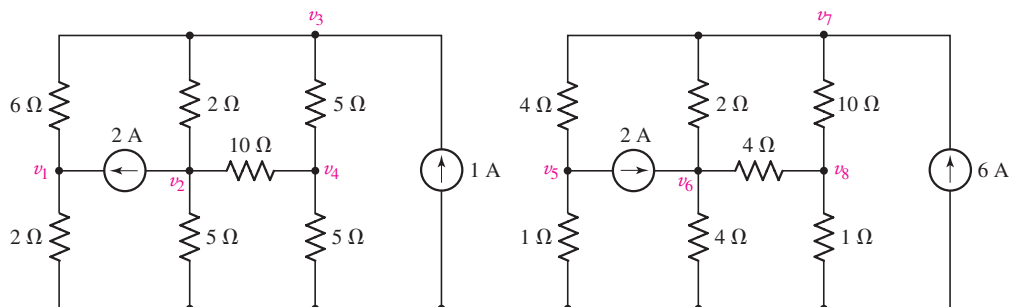

■ FIGURE 4.41

16. Determine the current  $i_2$  as labeled in the circuit of Fig. 4.42, with the assistance of nodal analysis.

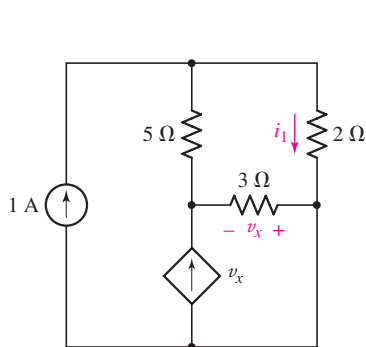

■ FIGURE 4.43

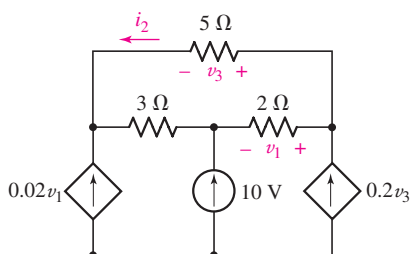

■ FIGURE 4.42

17. Using nodal analysis as appropriate, determine the current labeled  $i_1$  in the circuit of Fig. 4.43.

## 4.2 The Supernode

18. Determine the nodal voltages as labeled in Fig. 4.44, making use of the supernode technique as appropriate.

19. For the circuit shown in Fig. 4.45, determine a numerical value for the voltage labeled  $v_1$ .

20. For the circuit of Fig. 4.46, determine all four nodal voltages.

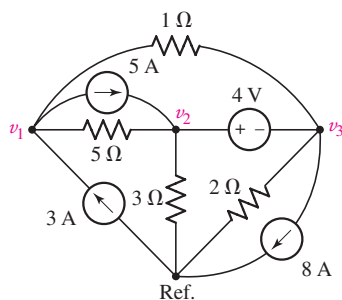

■ FIGURE 4.44

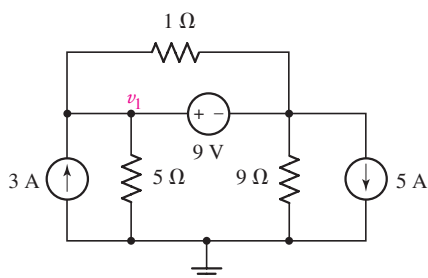

■ FIGURE 4.45

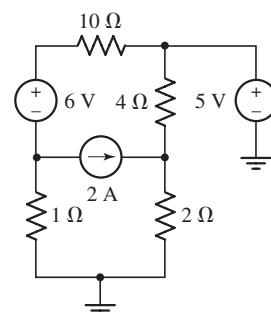

■ FIGURE 4.46

21. Employing supernode/nodal analysis techniques as appropriate, determine the power dissipated by the  $1\ \Omega$  resistor in the circuit of Fig. 4.47.

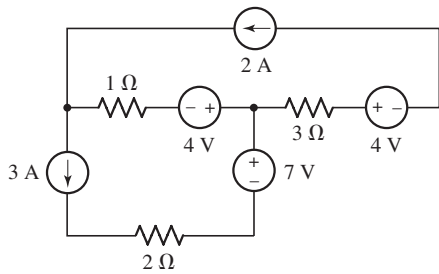

■ FIGURE 4.47

22. Referring to the circuit of Fig. 4.48, obtain a numerical value for the power supplied by the 1 V source.

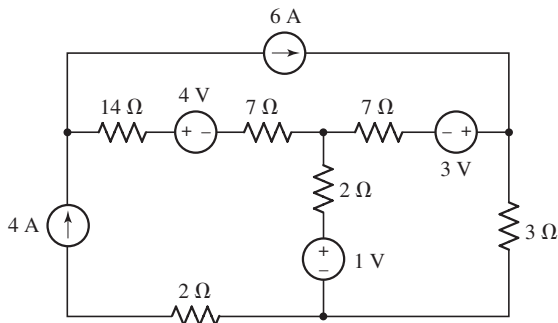

■ FIGURE 4.48

23. Determine the voltage labeled  $v$  in the circuit of Fig. 4.49.  
 24. Determine the voltage  $v_x$  in the circuit of Fig. 4.50, and the power supplied by the 1 A source.

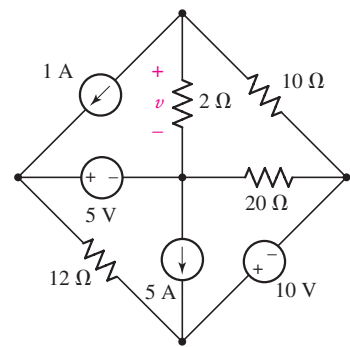

■ FIGURE 4.49

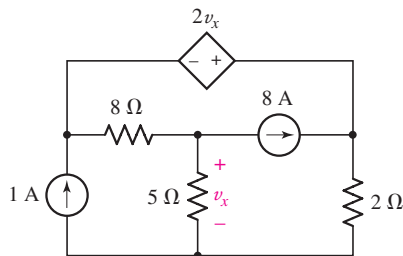

■ FIGURE 4.50

25. Consider the circuit of Fig. 4.51. Determine the current labeled  $i_1$ .

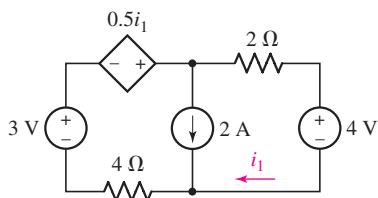

■ FIGURE 4.51

26. Determine the value of  $k$  that will result in  $v_x$  being equal to zero in the circuit of Fig. 4.52.

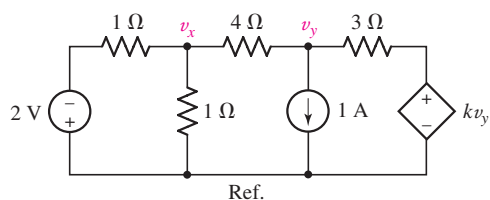

■ FIGURE 4.52

27. For the circuit depicted in Fig. 4.53, determine the voltage labeled  $v_1$  across the  $3\ \Omega$  resistor.

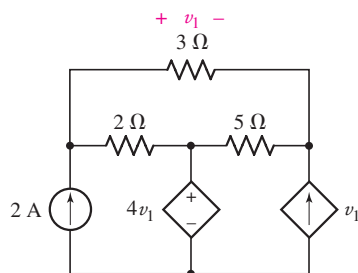

■ FIGURE 4.53

28. For the circuit of Fig. 4.54, determine all four nodal voltages.

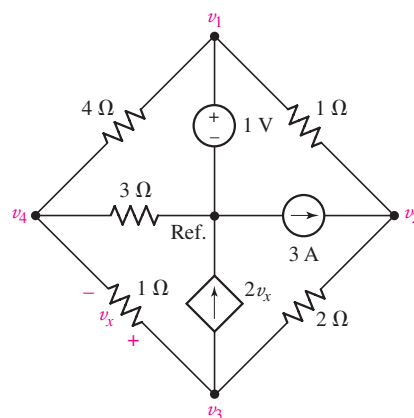

■ FIGURE 4.54

### 4.3 Mesh Analysis

29. Determine the currents flowing out of the positive terminal of each voltage source in the circuit of Fig. 4.55.

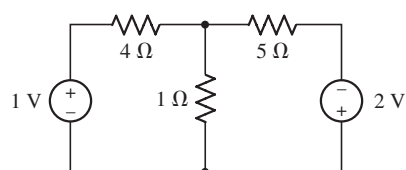

■ FIGURE 4.55

30. Obtain numerical values for the two mesh currents  $i_1$  and  $i_2$  in the circuit shown in Fig. 4.56.

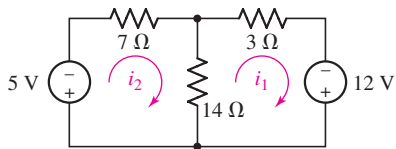

■ FIGURE 4.56

31. Use mesh analysis as appropriate to determine the two mesh currents labeled in Fig. 4.57.

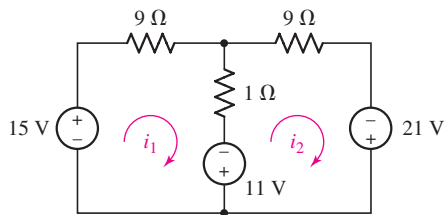

■ FIGURE 4.57

32. Determine numerical values for each of the three mesh currents as labeled in the circuit diagram of Fig. 4.58.

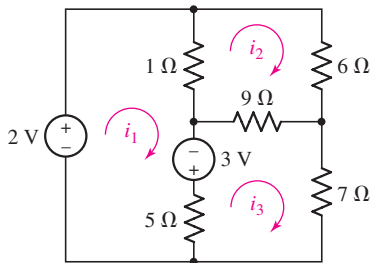

■ FIGURE 4.58

33. Calculate the power dissipated by each resistor in the circuit of Fig. 4.58.
34. Employing mesh analysis as appropriate, obtain (a) a value for the current  $i_y$  and (b) the power dissipated by the  $220\ \Omega$  resistor in the circuit of Fig. 4.59.
35. Choose nonzero values for the three voltage sources of Fig. 4.60 so that no current flows through any resistor in the circuit.

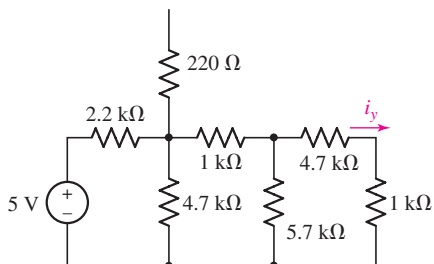

■ FIGURE 4.59

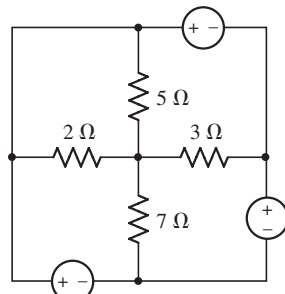

■ FIGURE 4.60

36. Calculate the current  $i_x$  in the circuit of Fig. 4.61.

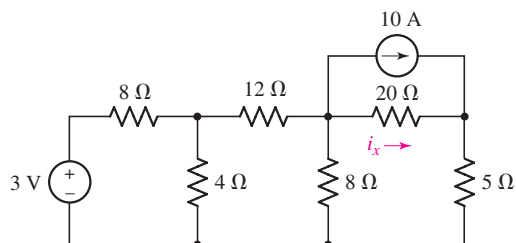

FIGURE 4.61

37. Employing mesh analysis procedures, obtain a value for the current labeled  $i$  in the circuit represented by Fig. 4.62.

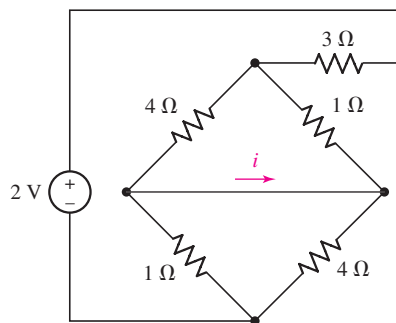

FIGURE 4.62

38. Determine the power dissipated in the  $4\ \Omega$  resistor of the circuit shown in Fig. 4.63.

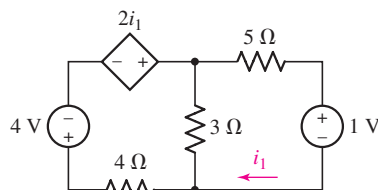

FIGURE 4.63

39. (a) Employ mesh analysis to determine the power dissipated by the  $1\ \Omega$  resistor in the circuit represented schematically by Fig. 4.64. (b) Check your answer using nodal analysis.

40. Define three clockwise mesh currents for the circuit of Fig. 4.65, and employ mesh analysis to obtain a value for each.

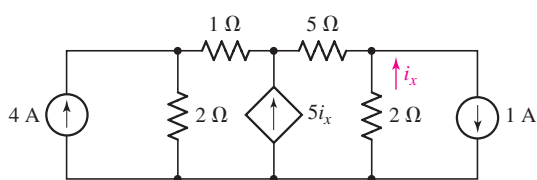

FIGURE 4.64

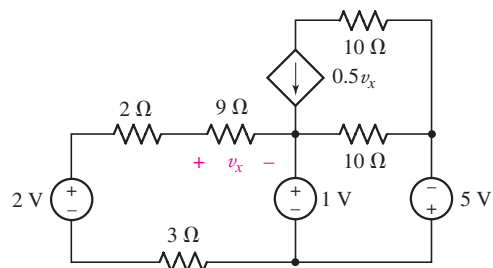
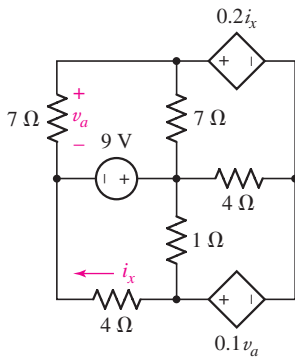

FIGURE 4.65

41. Employ mesh analysis to obtain values for  $i_x$  and  $v_a$  in the circuit of Fig. 4.66.



■ FIGURE 4.66

#### 4.4 The Supermesh

42. Determine values for the three mesh currents of Fig. 4.67.

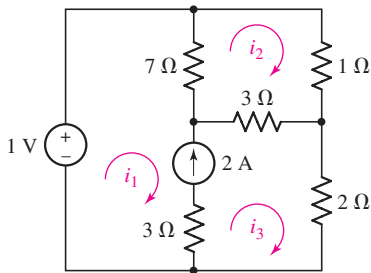

■ FIGURE 4.67

43. Through appropriate application of the supermesh technique, obtain a numerical value for the mesh current  $i_3$  in the circuit of Fig. 4.68, and calculate the power dissipated by the  $1\ \Omega$  resistor.

44. For the circuit of Fig. 4.69, determine the mesh current  $i_1$  and the power dissipated by the  $1\ \Omega$  resistor.

45. Calculate the three mesh currents labeled in the circuit diagram of Fig. 4.70.

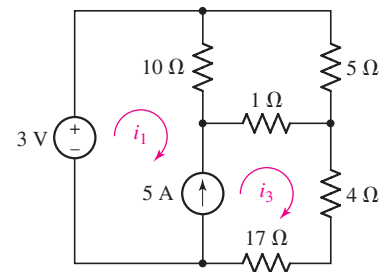

■ FIGURE 4.68

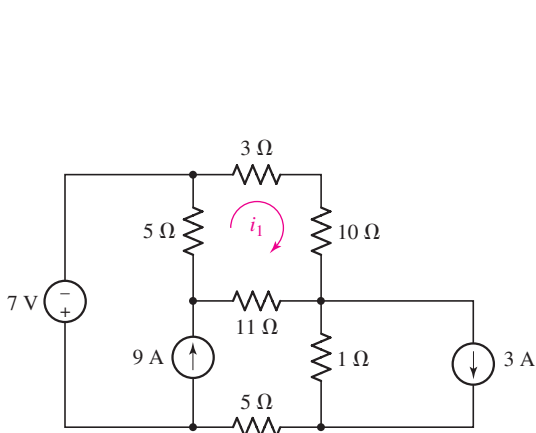

■ FIGURE 4.69

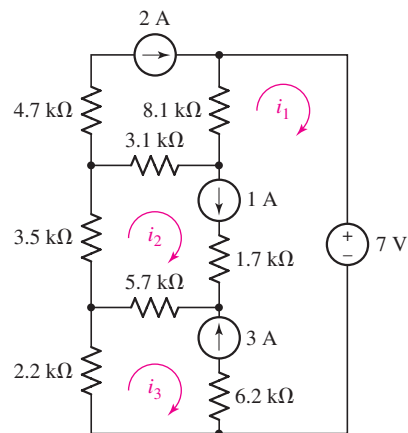

■ FIGURE 4.70

46. Employing the supermesh technique to best advantage, obtain numerical values for each of the mesh currents identified in the circuit depicted in Fig. 4.71.

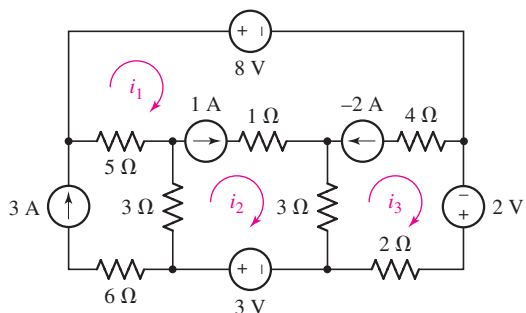

■ FIGURE 4.71

47. Through careful application of the supermesh technique, obtain values for all three mesh currents as labeled in Fig. 4.72.

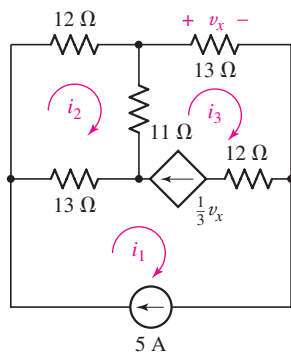

■ FIGURE 4.72

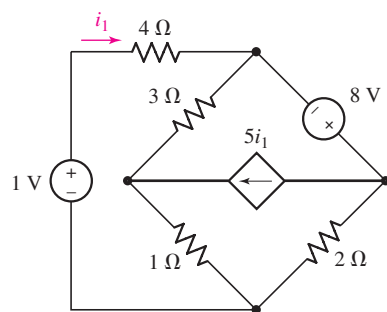

■ FIGURE 4.73

48. Determine the power supplied by the 1 V source in Fig. 4.73.  
 49. Define three clockwise mesh currents for the circuit of Fig. 4.74, and employ the supermesh technique to obtain a numerical value for each.  
 50. Determine the power absorbed by the 10 Ω resistor in Fig. 4.75.

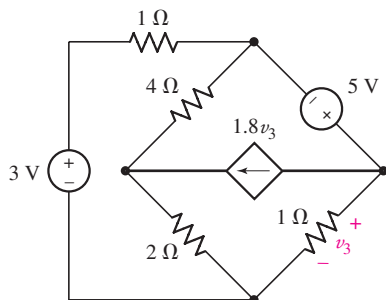

■ FIGURE 4.74

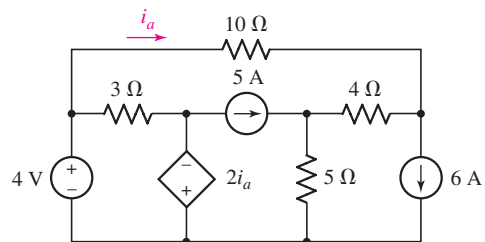

■ FIGURE 4.75



#### 4.5 Nodal vs. Mesh Analysis: A Comparison

51. For the circuit represented schematically in Fig. 4.76: (a) How many nodal equations would be required to determine  $i_5$ ? (b) Alternatively, how many mesh equations would be required? (c) Would your preferred analysis method change if only the voltage across the  $7\ \Omega$  resistor were needed? *Explain.*

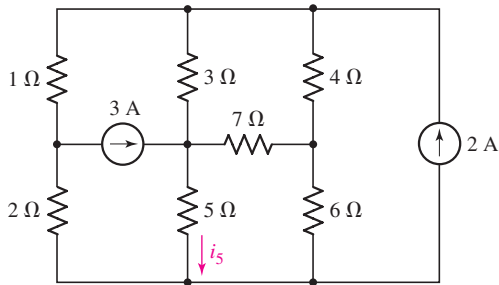

■ FIGURE 4.76

52. The circuit of Fig. 4.76 is modified such that the 3 A source is replaced by a 3 V source whose positive reference terminal is connected to the  $7\ \Omega$  resistor. (a) Determine the number of nodal equations required to determine  $i_5$ . (b) Alternatively, how many mesh equations would be required? (c) Would your preferred analysis method change if only the voltage across the  $7\ \Omega$  resistor were needed? *Explain.*
53. The circuit of Fig. 4.77 contains three sources. (a) As presently drawn, would nodal or mesh analysis result in fewer equations to determine the voltages  $v_1$  and  $v_2$ ? *Explain.* (b) If the voltage source were replaced with current sources, and the current source replaced with a voltage source, would your answer to part (a) change? *Explain?*

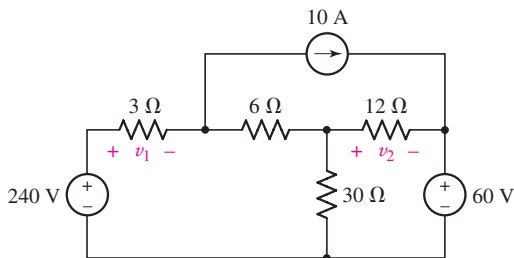

■ FIGURE 4.77

54. Solve for the voltage  $v_x$  as labeled in the circuit of Fig. 4.78 using (a) mesh analysis. (b) Repeat using nodal analysis. (c) Which approach was easier, and why?

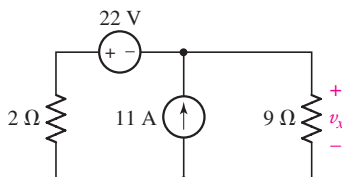

■ FIGURE 4.78

55. Consider the five-source circuit of Fig. 4.79. Determine the total number of simultaneous equations that must be solved in order to determine  $v_1$  using (a) nodal analysis; (b) mesh analysis. (c) Which method is preferred, and does it depend on which side of the  $40\ \Omega$  resistor is chosen as the reference node? Explain your answer.

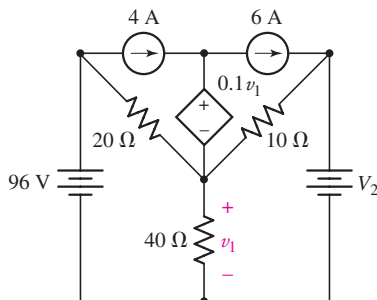

■ FIGURE 4.79

56. Replace the dependent voltage source in the circuit of Fig. 4.79 with a dependent current source oriented such that the arrow points upward. The controlling expression  $0.1v_1$  remains unchanged. The value  $V_2$  is zero. (a) Determine the total number of simultaneous equations required to obtain the power dissipated by the  $40\ \Omega$  resistor if nodal analysis is employed. (b) Is mesh analysis preferred instead? Explain.
57. After studying the circuit of Fig. 4.80, determine the total number of simultaneous equations that must be solved to determine voltages  $v_1$  and  $v_3$  using (a) nodal analysis; (b) mesh analysis.

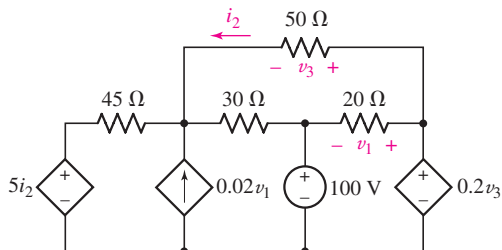

■ FIGURE 4.80



58. From the perspective of determining voltages and currents associated with all components, (a) design a five-node, four-mesh circuit that is analyzed more easily using nodal techniques. (b) Modify your circuit by replacing only one component such that it is now more easily analyzed using mesh techniques.

#### 4.6 Computer-Aided Circuit Analysis



59. Employ PSpice (or similar CAD tool) to verify the solution of Exercise 8. Submit a printout of a properly labeled schematic with the answer highlighted, along with your hand calculations.



60. Employ PSpice (or similar CAD tool) to verify the solution of Exercise 10. Submit a printout of a properly labeled schematic with the two nodal voltages highlighted, along with your hand calculations solving for the same quantities.



61. Employ PSpice (or similar CAD tool) to verify the voltage across the  $5\ \Omega$  resistor in the circuit of Exercise 13. Submit a printout of a properly labeled schematic with the answer highlighted, along with your hand calculations.

62. Verify numerical values for each nodal voltage in Exercise 15 by employing PSpice or a similar CAD tool. Submit a printout of an appropriately labeled schematic with the nodal voltages highlighted, along with your hand calculations.
63. Verify the numerical values for  $i_1$  and  $v_x$  as indicated in the circuit accompanying Exercise 17, using PSpice or a similar CAD tool. Submit a printout of a properly labeled schematic with the answers highlighted, along with hand calculations.
64. (a) Generate an input deck for SPICE to determine the voltage  $v_9$  as labeled in Fig. 4.81. Submit a printout of the output file with the solution highlighted. (b) Verify your answer by hand.

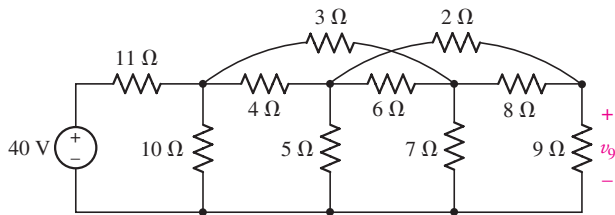

FIGURE 4.81

### Chapter-Integrating Exercises

65. (a) Design a circuit employing only 9 V batteries and standard 5% tolerance value resistors that provide voltages of 1.5 V, 4.5 V, and 5 V and at least one mesh current of 1 mA. (b) Verify your design using PSpice or similar CAD tool.
66. A decorative string of multicolored outdoor lights is installed on a home in a quiet residential area. After plugging the 12 V ac adapter into the electrical socket, the homeowner immediately notes that two bulbs are burned out. (a) Are the individual lights connected in series or parallel? *Explain.* (b) Simulate the string by writing a SPICE input deck, assuming 44 lights, 12 V dc power supply, 24 AWG soft solid copper wire, and individual bulbs rated at 10 mW each. Submit a printout of the output file, with the power supplied by the 12 V supply highlighted. (c) Verify your simulation with hand calculations.
67. Consider the circuit depicted in Fig. 4.82. Employ either nodal or mesh analysis as a design tool to obtain a value of 200 mA for  $i_1$ , if elements A, B, C, D, E, and F must be either current or voltage sources with nonzero values.

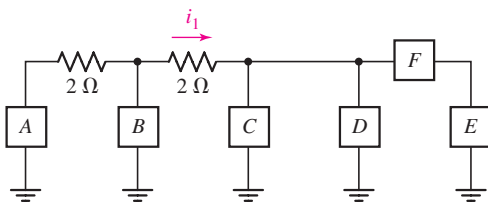
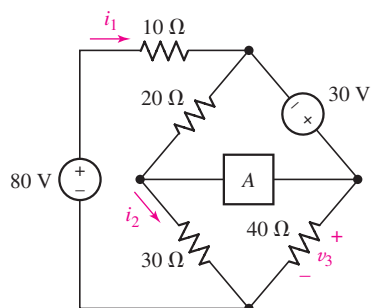

FIGURE 4.82

68. (a) Under what circumstances does the presence of an independent voltage source greatly simplify nodal analysis? *Explain.* (b) Under what circumstances does the presence of an independent current source significantly simplify mesh analysis? *Explain.* (c) On which fundamental physical principle do we base nodal analysis? (d) On which fundamental physical principle do we base mesh analysis?

69. Referring to Fig. 4.83, (a) determine whether nodal or mesh analysis is more appropriate in determining  $i_2$  if element A is replaced with a short circuit, then carry out the analysis. (b) Verify your answer with an appropriate PSpice simulation. Submit a properly labeled schematic along with the answer highlighted.



■ FIGURE 4.83

70. The element marked A in the circuit of Fig. 4.83 is replaced by a 2.5 V independent voltage source with the positive reference terminal connected to the common node of the 20 Ω and 30 Ω resistors. (a) Determine whether mesh or nodal analysis is more straightforward for determining the voltage marked  $v_3$ . (b) Verify your answer using PSpice. (c) Would your conclusion for part (a) change if the current  $i_2$  were required as well? *Explain.*