

Roll Number -



INDUS UNIVERSITY

# WORKSHOP PRACTICE

LABORATORY MANUAL

B.Tech. FIRST YEAR

**INDUS INSTITUTE OF TECHNOLOGY &  
ENGINEERING MECHANICAL ENGINEERING  
DEPARTMENT AHMEDABAD**

**CERTIFICATE**

*This is to certify that Mr./Ms./Mrs. \_\_\_\_\_*

*Reg.No. \_\_\_\_\_ of \_\_\_\_\_*

*class has satisfactory completed the course in*

\_\_\_\_\_

*at **INDUS INSTITUTE OF TECHNOLOGY & ENGINEERING,***

*Rancharda, Ahmedabad.*

*Date of Submission: \_\_\_\_\_*

*Concern Faculty: \_\_\_\_\_*

*Head of Department: \_\_\_\_\_*

# INDEX

---

Sr. No	Title	Page		Date of Start	Date of Comp.	Faculty Sign.	Gr.
		From	To				
1.	To study about safety rules in Mechanical Workshop.	7	7				
2.	To study about Workshop layout and preparation of actual layout of Mechanical Workshop	8	8				
3.	To study about Carpentry shop and preparation of job	9	19				
4.	To study about Fitting shop and preparation of job.	20	28				
5.	To study about Tin Smithy shop and preparation of job.	29	31				
<b>Assignments</b>							

**\* INSTRUCTIONS \***

- ✓ Laboratory manual is issued once only.
- ✓ Keep it in good condition up to Term Work submission & Viva Voca examination.
- ✓ Use only HB pencil to write in this manual.
- ✓ Writing should be neat and clean.
- ✓ Unreadable practical and assignments and / or not presented in a professional style will not receive credit (Higher Grades).
- ✓ At the end of the performance of the each practical, check the manual from the respective faculty member.

## Teaching and Examination Scheme

Subject: Workshop Practice								
Program: B. Tech. (F Y All Branches)				Subject Code: ME0117			Semester: I	
Teaching Scheme				Examination Evaluation Scheme				
Lecture	Tutorial	Practical	Credits	University Theory Examination	University Practical Examination	Continuous Internal Evaluation (CIE)- Theory	Continuous Internal Evaluation (CIE)- Practical	Total
0	0	4	2	-----	16/40	-----	24/60	100

### Course Objective:

1. Recognize the importance of Workshop in today's technology and its impacts on market competition.
2. Understand basic of various methodologies to manufacture components/structure.
3. Understand different tools and equipments used in mechanical workshop.
4. Analyze the engineering and economical aspects of workshop practices.

### Course Outcome:

After learning the course the students should be able to:

1. Prepare basic joints used in carpentry.
2. Prepare edges for better joint for fitting.
3. Prepare better joint for welding.
4. Prepare various shapes and objects by using Carpentry, Fitting, and Welding.

### Text Books & Reference Books :

- 1) Choudhary Hajara, "Elements of Workshop Technology", Media Promoters & Publishers.
- 2) Raghuvanshi B.S., "Workshop Technology" Vol. I & II, Dhanpat Rai & Sons.
- 3) Chapman W.A. J and Arnold E. "Workshop Technology" Low priced Student Edition.

**\* Units \***

<b>SI base units</b>				
<b>Name</b>	<b>Symbol</b>	<b>Quantity</b>	<b>Expression in terms of other units</b>	<b>Expression in terms of SI base units</b>
Newton	N	Force, Weight	$\text{m}\cdot\text{kg}/\text{s}^2$	$\text{m}\cdot\text{kg}\cdot\text{s}^{-2}$
joule	J	Energy, Work, Heat	$\text{N}\cdot\text{m}$	$\text{m}^2\cdot\text{kg}\cdot\text{s}^{-2}$
watt	W	Power	$\text{J}/\text{s}$	$\text{m}^2\cdot\text{kg}\cdot\text{s}^{-3}$
Pascal	Pa	Pressure, Stress	$\text{N}/\text{m}^2$	$\text{m}^{-1}\cdot\text{kg}\cdot\text{s}^{-2}$

<b>Some Important Derived Units</b>			
<b>Name</b>	<b>Symbol</b>	<b>Quantity</b>	<b>Expression in terms of SI base units</b>
Square metre	$\text{m}^2$	<b>area</b>	$\text{m}^2$
Cubic metre	$\text{m}^3$	<b>volume</b>	$\text{m}^3$
Metre per second	$\text{s} \cdot \text{m}^{-1}$	<b>speed, velocity</b>	$\text{m}\cdot\text{s}^{-1}$
Metre per second squared	$\text{s} \cdot \text{m}^{-2}$	<b>acceleration</b>	$\text{m}\cdot\text{s}^{-2}$
Radian per second	$\text{s} \cdot \text{rad}$	<b>angular velocity</b>	$\text{s}^{-1}$
Newton second	$\text{N}\cdot\text{s}$	<b>momentum, impulse</b>	$\text{s} \cdot \text{kg}\cdot\text{m}^{-1}$
Newton metre second	$\text{N}\cdot\text{m}\cdot\text{s}$	<b>angular momentum</b>	$\text{s} \cdot \text{kg}\cdot\text{m}^2\cdot\text{s}^{-1}$
Newton metre	$\text{N}\cdot\text{m}$	<b>torque, moment of force</b>	$\text{s} \cdot \text{kg}\cdot\text{m}^2\cdot\text{s}^{-2}$
Kilogram per cubic metre	$\text{kg}\cdot\text{m}^{-3}$	<b>density, mass density</b>	$\text{kg}\cdot\text{m}^{-3}$
Cubic metre per kilogram	$\text{kg}^{-1}\cdot\text{m}^3$	<b>specific volume</b>	$\text{kg}^{-1}\cdot\text{m}^3$
Mass Moment of Inertia	$\text{m} \cdot \text{kg}\cdot\text{m}^2$	<b>Mass Moment of Inertia</b>	$\text{kg}\cdot\text{m}^2$

# **PRACTICAL: 1**

## **To study about safety rules in Mechanical Workshop**

### **Introduction:**

Safety is a vital issue in all workplaces. Before using any equipment and machines or attempt practical work in a workshop everyone must understand basic safety rules. These rules will help keep all safe in the workshop.

### **Safety Rules:**

1. Always listen carefully to the teacher and follow instructions.
2. When learning how to use a machine, listen very carefully to all the instructions given by the teacher. Ask questions, especially if you do not fully understand.
3. Do not run in the workshop.
4. Always wear an apron as it will protect your clothes and holds loose clothing such as ties in place.
5. Wear good strong shoes.
6. Bags should not be brought into a workshop as people can trip over them.
7. Do not use a machine if you have not been shown how to operate it safely by the teacher.
8. Know where the emergency stop buttons are positioned in the workshop. If you see an accident at the other side of the workshop you can use the emergency stop button to turn off all electrical power to machines.
9. Wherever required, wear protective equipment, such as goggles, safety glasses, masks, gloves, hair nets, etc.
10. Always be patient, never rush in the workshop.
11. Always use a guard when working on a machine.
12. Keep hands away from moving/rotating machinery.
13. Use hand tools carefully, keeping both hands behind the cutting edge.
14. Do not tamper with electric controls or switches.
15. Report any UNSAFE condition or acts to instructor.
16. Report any damage to machines/equipment as this could cause an accident.
17. Keep your work area clean.

## PRACTICAL: 2

### To study about Workshop layout and preparation of actual layout of Mechanical Workshop

#### Introduction:

The word workshop is a combination of two separate words Work and Shop.

Mechanical workshop is a room or building which provides both area and tools (or machinery) that may be required for the manufacture of the goods. Every engineer in any way is associated with workshop.

Students are expected to know basic workshop practice like Wood working, Sheet metal, metal joining processes, manufacturing processes etc. they are required to identify, operate and control various machines, tools and equipments.

The student will able to

- ☐ Know basic workshop processes.
- ☐ Read and interpret job drawing.
- ☐ Identify, select and use various marking, measuring, holding, striking and cutting tools & equipments.
- ☐ Operate and control different machines and equipments.
- ☐ Inspect the job for specified dimensions
- ☐ Produce jobs as per specified dimensions.
- ☐ Adopt safety practices while working on various machines.

Following sections are there in the Workshop:

1. Carpentry Shop
2. Fitting Shop
3. Tin Smithy Shop
4. Black Smithy Shop
5. Welding Shop
6. Machining Shop
7. Plumbing Shop

#### Exercise-2

1. Draw the detail layout of the workshop showing all the sections and instructors places.
2. Draw the layout and list the tools and equipments in the following sections.
  - a. Carpentry Shop
  - b. Fitting Shop
  - c. Tin Smithy Shop
  - d. Black Smithy Shop
  - e. Welding Shop
  - f. Machining Shop
  - g. Plumbing Shop



## PRACTICAL: 3

### To study about Carpentry shop and preparation of job

#### Introduction:

Carpenters are skilled craftsmen who build structures and products from wood and other similar materials. Carpentry and joinery are common terms used with any class of work with wood and other similar materials. Carpentry deals with all constructional work of building such as making of doors, windows, cupboards, stairs etc. It is also used to make the prototypes of the product using wood materials.

#### Carpentry Material/s:

There are many varieties of stock available to woodworkers. Each species has different rules for getting the most out of that particular type of wood. In this list, find woodworking tips for dealing with just a few of the most popular varieties of wood used for woodworking, such as oak, maple, pine and more.

<u>Name</u>	<u>Colour</u>	<u>Density</u>	<u>Characteristics, Usage and Status</u>
Babul	Whitish red	835 kg/m <sup>3</sup>	It is strong, hard and tough and it takes up a good polish. It is used for such products as bodies and wheels of bullock cart, agricultural instruments, tool handles, and well curbs.
Deodar	Yellowish brown	560 kg/m <sup>3</sup>	Deodar is the most important timber tree providing soft wood. It can be easily worked and it is moderately strong. It possesses distinct annual rings. It is used for making cheap furniture, railway carriages, railway sleepers, packing boxes, structural work and so forth.
Mahogany	Reddish brown	720 kg/m <sup>3</sup>	It takes a good polish and is easily worked. It is durable under water. It is most commonly used for furniture, pattern making and cabinet work.
Mango	Deep gray	560-720 kg/m <sup>3</sup>	The mango tree is well known for its fruits. It is easy to work and it maintains its shape well. It is moderately strong. It is most often used for cheap furniture, toys, packing boxes, cabinet work, and panels for doors and for windows.
Oak	Yellowish brown	865 kg/m <sup>3</sup>	Oak is strong and durable, with straight silvery grain. It is used for preparing sporting goods.
Sal	Brown	880-1050 kg/m <sup>3</sup>	It is hard, fibrous and close-grained. It does not take up a good polish. It requires slow and careful seasoning. It is

			durable underground and water. It is used for railway Sleepers, shipbuilding, and bridges.
Sandalwood	White or Red	930 kg/m <sup>3</sup>	It has a pleasant smell. It is commonly used for agricultural instruments, well curbs, wheels, and mallets.
Sissoo	Dark brown	770 kg/m <sup>3</sup>	Also known as shisham or tali, this wood is strong and tough. It is durable and handsome and it maintains its shape well. It can be easily seasoned. It is difficult to work but it takes a fine polish. It is used for high quality furniture, plywoods, bridge piles, sport goods, railway sleepers and so forth. It is a very good material for decorative works and carvings.
Teak	Deep yellow to dark brown	639 kg/m <sup>3</sup>	Moderately hard, teak is durable and fire-resistant. It can be easily seasoned and worked. It takes up a good polish and is not attacked by white ants and dry rot. It does not corrode iron fastenings and it shrinks little. It is among the most valuable timber trees of the world and its use is limited to superior work only.
Mulberry	Brown	650 kg/m <sup>3</sup>	It is strong, tough and elastic. It takes up a clean finish. It can be well seasoned. It is turned and carved easily. Mulberry is typically used for baskets and sports goods like hockey sticks, tennis rackets and cricket bats.

Engineered wood, also called composite wood or man-made wood, includes a range of derivative wood products which are manufactured by binding together the strands, particles, fibers, or veneers of wood, together with adhesives, to form composite materials. These products are engineered to precise design specifications which are tested to meet national or international standards.

applications due to certain comparative advantages:

- Because engineered wood is human-made, it can be designed to meet application-specific performance requirements.
- Large panels of engineered wood may be manufactured from fibers of small diameter trees.
- Small pieces of wood, and wood that has defects, can be used in many engineered wood products, especially particle and fiber-based boards.

Following are the some of the manmade woods generally used for industrial and household applications:

### 1. Plywood

Plywood is a manufactured wood, made by gluing together a number of thin veneers or plies of softwood or hardwood. It is used mostly in commercial sites, purely because it is a strong durable substance.

### 2. Block board:

Blockboard is made up of a core of softwood strips. These strips may be up to about 25mm wide.

The strips are placed edge to edge and sandwiched between veneers of hardwood. The sandwich is then glued under high pressure. Blockboard is not suitable for outdoor use because the glues used are interior glues. When using blockboard to make such things as doors or tables, it is important to ensure that the core runs lengthways in order to achieve maximum strength.

### **Tools and Equipments used in Carpentry Shop:**

The tools that are used for carpentry work are as follows:

1. Marking and measuring tools
2. Cutting tools
3. Planning tools
4. Boring tools
5. Sinking tools
6. Holding tools

### **Marking and Measuring Tool**

#### **Carpenter's Rule**

Measuring stick consisting of a strip of wood or metal or plastic with a straight edge is used for drawing straight lines and measuring lengths. It are made portable by folding (carpenter's folding rule) or retracting into a coil (metal tape measure) when not in use. When extended for use they are straight. They are in the range of 0 -60 cm.

#### **Straight Rule**

A straight rule, or rule, is an instrument used in geometry, technical drawing and engineering/building to measure distances and/or to rule straight lines. The ruler is essentially a straightedge used to rule lines and the calibrated instrument used for determining measurement.

#### **Try Square**

A try-square is a woodworking or a metal working tool used for marking and measuring a piece of wood. The square refers to the tool's primary use of measuring the accuracy of a right angle (90 degrees); to try a surface is to check its straightness or correspondence to an adjoining surface. A piece of wood that is rectangular, flat, and has all edges (faces, sides, and ends) 90 degrees is called four square. A board is often milled four squares in preparation for using it in building furniture. it is useful for getting right angles Try-square is sometimes spelled "tri square".

#### **Marking Gauge**

A marking gauge is used to mark a line parallel to a straight edge. The stem and stock are made from beech and the thumbscrew from clear yellow plastic. The better quality gauges have brass inserts at the front of the stock. These help reduce the wear on the stock as it is pushed against the surface of the wood - to be marked. The marking gauge is an extremely important tool for marking parallel lines and preparing for cutting joints.

#### **Divider**

A divider, also known as a measuring compass, is a mathematical, drafting or cartographic instrument used to aid measurements of the length of irregular lines and of distances on maps or charts. It is commonly used in geometry and in nautical navigation. It is similar in appearance to a drafting compass, the difference being that the drafting compass has a spike on one end and a pencil (or other drawing utensil) on the other which allows the drawing of

circles, whereas the dividers has spikes on both ends. Often a compass can be fitted with a spike in place of the drawing utensil and thus converted to dividers.

### **Cutting Tools Saws**

A saw is a tool that uses a hard blade with an abrasive edge to cut through softer materials. The cutting edge of a saw is either a serrated blade or an abrasive. A saw may be worked by hand, or powered by steam, water, electricity or other power.

#### **Rip Saw**

In woodworking, a cut made parallel to the direction of the grain of the workpiece is known as a rip cut. If one were to cut a tree trunk in half from top to bottom, this would be a rip cut — but the term also applies to cutting free lumber. A rip saw is a saw that is specially designed for making rip cuts. The cutting edge of each tooth has a flat front edge and it is not angled forward or backward. It is about 700 mm long with 3 – 5 points or teeth per 25 mm.

#### **Cross Cut Saw**

A crosscut saw is a saw that is specially designed for making crosscuts. A crosscut is a cut made horizontally through the trunk of a standing tree, but the term also applies to cutting free lumber. Crosscut saws have teeth that are designed to cut wood at a right angle to the direction of the wood grain. The cutting edge of each tooth is angled back and has a beveled edge. This design allows each tooth to act like a knife edge and slice through the wood, in contrast to a rip saw, which tears along the grain, acting like a miniature chisel. It is about 650 mm long with 8 – 10 points or teeth per 25 mm.

#### **Panel Saw**

Panel saw is any type of sawing machine that cuts sheets into sized parts. Panel saws are used by cabinet shops to easily cut plywood and melamine sheets into cabinet components. They are also used by sign shops to cut sheets of aluminum, plastic and wood for their sign blanks. Panel saws typically fall into one of two categories: Horizontal and Vertical. Some higher end panel saws feature computer controls that move the blade and fence systems to preset values. Other lower end machines offer simplicity and ease of use. It is about 500 mm long with 10 – 12 points or teeth per 25 mm.

#### **Tenon or Back Saw**

A backsaw is any hand saw which has a stiffening rib on the edge opposite the cutting edge, allowing for better control and more precise cutting than with other types of saws. Backsaws are normally used in woodworking for precise work, such as cutting dovetails, tenons in cabinetry and joinery. Because of the stiffening rib, the backsaws are limited in the depth to which they can cut. Backsaws usually have relatively closely-spaced teeth, often with little or no set. It is about 400 mm long with 12 – 13 points or teeth per 25 mm.

#### **Dovetail Saw**

A small backsaw used by furniture makers to cut dovetails and other fine joints. Besides its small size, the distinguishing feature of the dovetail saw that separates it from other backsaws is the thickness of its blade – about 26 gauge. Other backsaws can be about 0.65 mm – 1 mm depending on length and intended purpose. A thin blade and its resulting kerfs allow the most accurate saw cut for a small joint like a drawer's dovetail. It is about 200 mm long with 12 – 13 points or teeth per 25 mm.

**Bow Saw**

A bow saw is a metal-framed saw in the shape of a bow with a coarse wide blade. This type of saw is also known as a sewed saw or a buck saw. It is a rough tool that can be used for cross-cutting branches (maybe up to 6 inches in diameter) down to size. Traditionally, a bow saw is a woodworking tool used for straight or curved cuts.

**Compass Saw**

A handsaw with a narrow triangular blade is used for cutting circles and curves in wood. Compass saws have longer, coarser blades than keyhole saws. They are designed for slightly heavier work such as cutting holes in subflooring for plumbing or electrical wiring.

**Chisels**

A chisel is a tool with a characteristically shaped cutting edge (such that wood chisels have lent part of their name to a particular grind) of blade on its end, for carving or cutting a hard material such as wood, stone, or metal. The handle and blade of some types of chisel are made of metal or wood with a sharp edge in it. In use, the chisel is forced into the material to cut the material. The driving force may be manually applied or applied using a mallet or hammer. In industrial use, a hydraulic ram or falling weight ('trip hammer') drives the chisel into the material to be cut.

**Firmer Chisel**

The firmer chisel is used to remove fairly large pieces of waste and because the blade is thicker it can withstand rough treatment, but not hitting with a mallet. The paring chisel is used for taking off small quantities of wood in thin slices. The blade is thinner and will not stand knocking about. The mortise chisel is used for chopping mortises (rectangular holes) and is robust with a shock absorbing washer to enable it to be struck with a mallet. It has blade about 125 mm long and the width varies from 1.5 to 50 mm.

**Bevel Chisel**

A chisel is used for cutting wood, having its cutting edge at an angle to the sides. They are slightly undercut making them easy to push into corners. They are normally used for finishing dovetail joints.

**Mortise Chisel**

Mortise chisels are used for 'chopping out' joints (chiseling away the waste wood). They are particularly useful for cutting mortise joints as they are strong enough to withstand heavy blows with a mallet. Blade width varies from 3 – 16 mm.

**Planing Tools****Jack Plane**

A jack plane is the general-purpose bench plane, used for general smoothing of the edges, sizing of wood and jointing edges. Jack planes are about 400 mm long and the blade can have either a slightly curved edge for smoothing stock, or a straight edge for jointing stock.

**Trying Plane**

Trying plane is a type of hand plane used primarily to straighten the edges of boards in the operation known as jointing. A jointer plane may also be used to flatten the face of a board. Its long length is designed to 'ride over' the undulations of an uneven surface, skimming off the peaks, gradually creating a flat surface. In thickening or preparing rough stock, the

jointer plane is usually preceded by the jack plane and followed by the smoothing plane. These are typically 510 to 610 mm long.

### **Smoothing Plane**

A smoothing plane or smooth plane is a type of bench plane used in woodworking. The smoothing plane is typically the last plane used on a wood surface - when used properly; the finish it gives will be far superior to that made by sandpaper or scrapers. The smooth finish is the result of planing the wood off in strips, rather than by successive buffing and scratching. The smoothing plane is typically 8 to 10 inches long.

### **Rebate Plane**

The rebate plane (also known as the rabbet plane) is a hand plane designed for cutting rebates in wood. The rebate plane is one of a group of planes including the shoulder plane, bull nose plane and carriage makers plane in which the blade protrudes by a very small amount - usually less than half a millimeter - from the sides of the plane body on both sides. The blade is very slightly wider than the body of the plane.

### **Metal Plane**

The metal plane serves the same purpose but facilitate a smoother operation. The body of the metal plane is made of a grey iron casting. The thickness of the shaving blade removed is governed by a fine screw adjustment and a lever is used for adjusting the blade at right angle.

### **Boring Tools**

Boring tools are used to make round holes in wood and they are selected according to the type and the purpose of the hole. They include bradawl, gimlet, brace and drill bit.

### **Bradawl**

A bradawl is a tool with a blade similar to that of a straight screwdriver and a handle made from wood or plastic. A bradawl is used to make an indentation in wood or other materials in order to ease the insertion of a nail or screw. The blade is placed across the fibers of the wood, cutting them when pressure is applied - the bradawl is then twisted through 90 degrees which displaces the fibers creating a hole. This cutting action helps to prevent splitting of the wood along the grain.

### **Gimlet**

A gimlet is a hand tool for drilling small holes, mainly in wood, without splitting. A gimlet is always a small tool. The cutting action of the gimlet is slightly different; the cutting edges pare away the wood which is moved out by the spiral sides, falling out through the entry hole. This also pulls the gimlet further into the hole as it is turned; unlike a bradawl, pressure is not required once the tip has been drawn in.

### **Drill Bit**

Drill bits are cutting tools used to create cylindrical holes. Bits are held in a tool called a drill, which rotates them and provides torque and axial force to create the hole. Specialized bits are also available for non-cylindrical-shaped holes.

### **Striking Tools**

### **Hammers**

A hammer is a tool meant to deliver an impact to an object. The most common uses are for

driving nails, fitting parts, forging metal and breaking up objects. Hammers are often designed for a specific purpose, and vary widely in their shape and structure. The usual features are a handle and a head, with most of the weight in the head. The basic design is hand-operated, but there are also many mechanically operated models for heavier uses.

### **Mallets**

A mallet is a kind of hammer, usually of wood, smaller than a maul or beetle and usually with a relatively large head. Wooden mallet, usually used in carpentry to knock wooden pieces together or to drive dowels or chisels. A wooden mallet will not deform the striking end of a metal tool, as most metal hammers would, but it also reduces the force available to drive the cutting edge of a chisel. Hardwood mallet is also used to knock in a cricket bat. Rubber mallets are used when a softer blow is called for than that delivered by a metal hammer. They are typically used to form sheet metal, since they don't leave marks, as well as for forcing tight-fitting parts together, for shifting plasterboard into place, in upholstery, and a variety of other general purposes, including some toys. It is the most commonly used mallet.

### **Holding Tool**

#### **Bench Vice**

A vise or vice (see American and British English spelling differences) is a mechanical screw apparatus used for holding or clamping a work piece to allow work to be performed on it with tools such as saws, planes, drills, mills, screwdrivers, sandpaper, etc. Vises usually have one fixed jaw and another, parallel, jaw which is moved towards or away from the fixed jaw by the screw.

#### **Bench Stop**

Bench stop is simply a block of wood projecting above the top surface of the bench. This is used to prevent the wood from moving forward when being planned. The other types of holding devices used are bench holdfast, sash clamp, G cramp, hand screw etc.

### **Carpentry Joints**

There are many kinds of joints used to connect wood stock. Each joint has a definite use and requires lay in-out, cutting them together. The strength of the joint depends upon amount of contact area. If a particular joint does not have much contact area, then it must be reinforced with nails, screws or dowels.

#### **Lap Joint**

In lap joints, an equal amount of wood is removed from each piece, as shown in figure. Lap joints are easy to layout, using a try-square and a marking gauge. Follow the procedure suggested for sawing and removing the waste stock. If the joint is found to be too tight, it is better to reduce the width of the mating piece, instead of trimming the shoulder of the joint. This type of joint is used for small boxes to large pieces of furniture.

#### **Bridle Joint**

This is the reverse of mortise and tenon joint in form. The marking-out of the joint is the same as for mortise and tenon joint. This joint is used where the members are of square or near square section and unsuitable for mortise and tenon joint.



Panel Saw



Dovetail Saw



Dovetail Saw



Bow Saw



Compass Saw

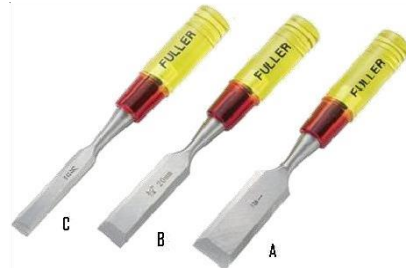

A - fiemer Chisel / B - Bevel Chisel / C - Mortise Chisel



Jack Plane



Smoothing Plane



Rebate plane



Metal Plane

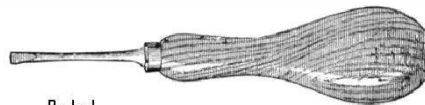

Bradawl





Gimlet



Drill Bit



Hammer



Mallet

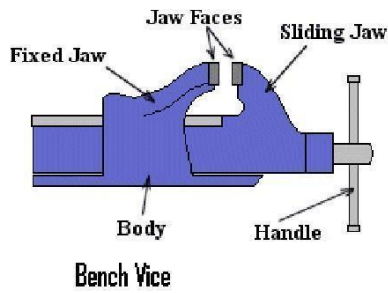

Bench Vice

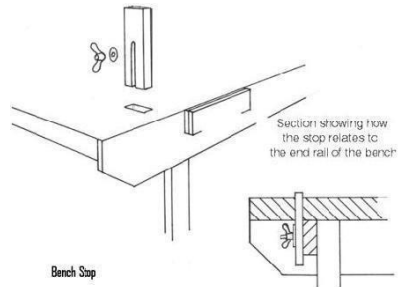

Bench Stop

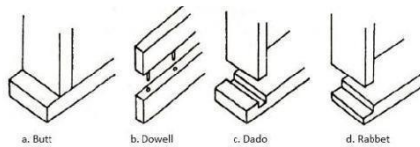

a. Butt

b. Dowel

c. Dado

d. Rabbet

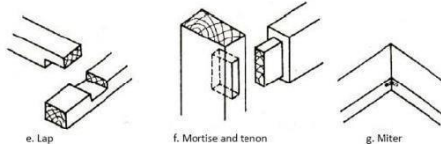

e. Lap

f. Mortise and tenon

g. Miter

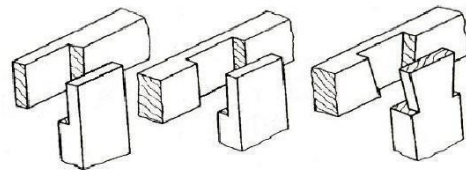

Lap joints

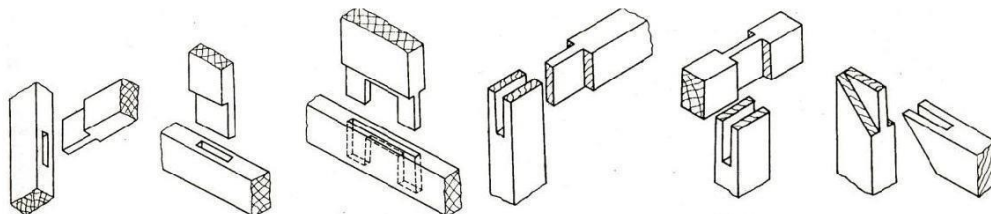

Mortise and Tenon Joint

Bridle Joint

**Exercise 3**

1. What does mean by carpentry?
2. Classify the tools used in carpentry shop.
3. List the various marking and measuring tools.
4. Explain the following with neat sketch:
  - a. Carpenter's Rule
  - b. Try Square
  - c. Marking Gauge
5. List the various cutting tools.
6. List the various planing tools in carpentry.
7. What does mean by boring tools? List the various boring tools.
8. Explain the following with neat sketch
  - a. Bench Vice
  - b. Mallet
9. Explain the following carpentry joints stating their applications:
  - a. Lap Joint
  - b. Bridal Joint
10. To Prepare Carpentry job as per given drawing.

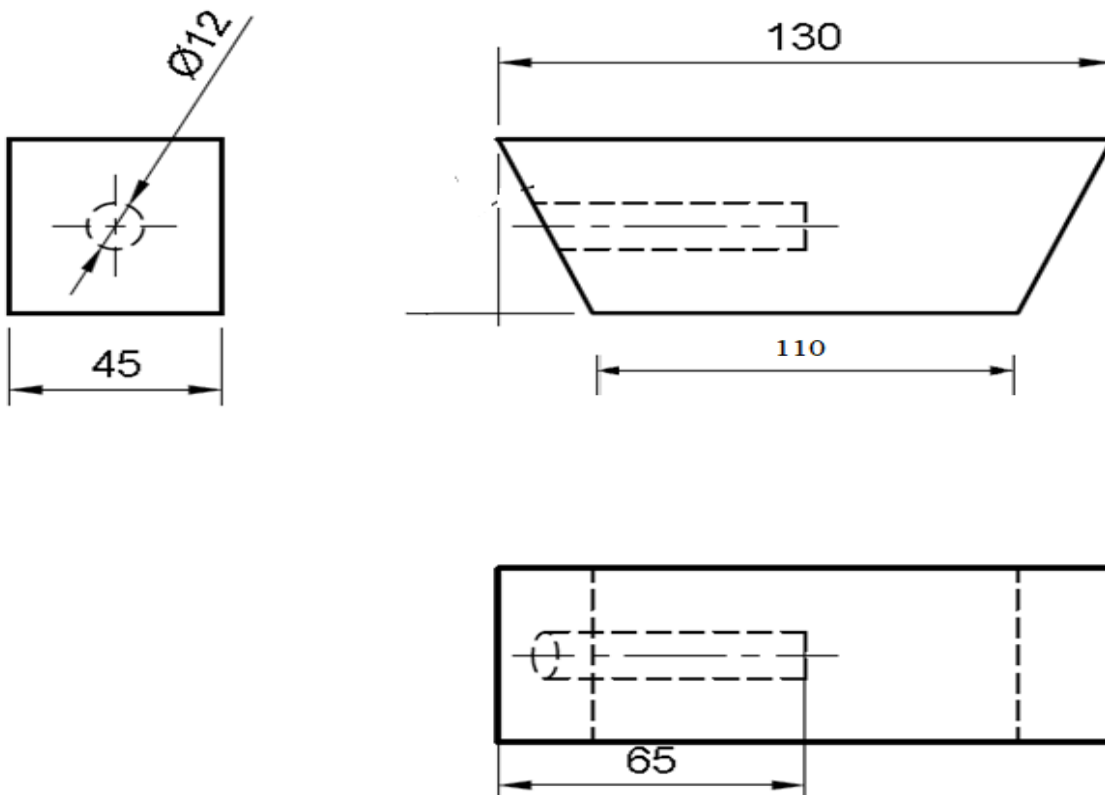

## PRACTICAL: 4

### To study about Fitting shop and preparation of job.

#### Introduction:

Machine tools are capable of producing work at a faster rate, but, there are occasions when components are processed at the bench. Sometimes, it becomes necessary to replace or repair component which must be fit accurately with another component on reassembly. This involves a certain amount of hand fitting. The assembly of machine tools, jigs, gauges, etc, involves certain amount of bench work. The accuracy of work done depends upon the experience and skill of the fitter.

The term 'bench work' refers to the production of components by hand on the bench, where as fitting deals with the assembly of mating parts, through removal of metal, to obtain the required fit. Both the bench work and fitting requires the use of number of simple hand tools and considerable manual efforts. The operations in the above works consist of filing, chipping, scraping, sawing drilling, and tapping.

#### Tool used in Fitting Shop:

Tools used in fitting shop are classified as follows:

1. Holding Tools
2. Marking and Measuring Tools
3. Cutting Tools
4. Miscellaneous Tools

#### Holding Tools

##### Bench vice

The bench vice is a work holding device. It is the most commonly used vice in a fitting shop. It is fixed to the bench with bolts and nuts. The vice body consists of two main parts, fixed jaw and movable jaw. When the vice handle is turned in a clockwise direction, the sliding jaw forces the work against the fixed jaw. Jaw plates are made of hardened steel. Serrations on the jaws ensure a good grip. Jaw caps made of soft material are used to protect finished surfaces, gripped in the vice. The size of the vice is specified by the length of the jaws. The vice body is made of cast Iron which is strong in compression, weak in tension and so fractures under shocks and therefore should never be hammered.

##### V - Block

V-block is rectangular or square block with a V-groove on one or both sides opposite to each other. The angle of the 'V' is usually 90°. V-block with a clamp is used to hold Cylindrical work securely, during layout of measurement, for measuring operations or for

drilling for this the bar is faced longitudinally in the V-Groove and the screw of V-clamp tightened. This grip the rod is firm with its axis parallel to the axis of the v-groove.

### **C - Clamp**

This is used to hold work against an angle plate or v-block or any other surface, when gripping is required. Its fixed jaw is shaped like English alphabet 'C' and the movable jaw is round in shape and directly fitted to the threaded screw at the end .The working principle of this clamp is the same as that of the bench vice.

## **Marking & Measuring Tools**

### **Surface Plate**

The surface plate is machined to fine limits and is used for testing the flatness of the work piece. It is also used for marking out small box and is more precious than the marking table. The degree of the finished depends upon whether it is designed for bench work in a fitting shop or for using in an inspection room; the surface plate is made of Cast Iron, hardened Steel or Granite stone. It is specified by length, width, height and grade. Handles are provided on two opposite sides, to carry it while shifting from one place to another.

### **Try Square**

It is measuring and marking tool for 90 angle .In practice, it is used for checking the squareness of many types of small works when extreme accuracy is not required .The blade of the Try square is made of hardened steel and the stock of cast Iron or steel. The size of the Try square is specified by the length of the blade.

### **Scriber**

A Scriber is a slender steel tool, used to scribe or mark lines on metal work pieces. It is made of hardened and tempered High Carbon Steel. The Tip of the scriber is generally ground at 12 to 15 . It is generally available in lengths, ranging from 125mm to 250mm .It has two pointed ends the bent end is used or marking lines where the straight end cannot reach.

### **Odd leg Caliper**

This is also called 'Jenny Caliper' or Hermaphrodite. This is used for marking parallel liners from a finished edge and also for locating the center of round bars; it has one leg pointed like a divider and the other leg bent like a caliper. It is specified by the length of the leg up to the hinge point.

### **Divider**

It is basically similar to the calipers except that its legs are kept straight and pointed at the measuring edge. This is used for marking circles, arcs laying out perpendicular lines, by

setting lines. It is made of case hardened mild steel or hardened and tempered low carbon steel. Its size is specified by the length of the leg.

### **Punches**

These are used for making indentations on the scribed lines, to make them visible clearly. These are made of high carbon steel. A punch is specified by its length and diameter (say as 150' 12.5mm). It consists of a cylindrical knurled body, which is plain for some length at the top of it. At the other end, it is ground to a point. The tapered point of the punch is hardened over a length of 20 to 30mm. Dot punch is used to lightly indent along the layout lines, to locate center of holes and to provide a small center mark for divider point, etc. for this purpose, the punch is ground to a conical point having 60° included angle. Center punch is similar to the dot punch, except that it is ground to a conical point having 90° included angle. It is used to mark the location of the holes to be drilled.

### **Calipers**

They are indirect measuring tools used to measure or transfer linear dimensions. These are used with the help of a steel Rule to check inside and outside measurements. These are made of Case hardened mild steel or hardened and tempered low carbon steel. While using, but the legs of the caliper are set against the surface of the work, whether inside or outside and the distance between the legs is measured with the help of a scale and the same can be transferred to another desired place. These are specified by the length of the leg. In the case of outside caliper, the legs are bent inwards and in the case of inside caliper, the legs bent outwards.

### **Cutting Tools**

#### **Hack Saw**

The Hack Saw is used for cutting metal by hand. It consists of a frame, which holds a thin blade, firmly in position. Hacksaw blade is specified by the number of teeth for centimeter. Hacksaw blades have a number of teeth ranging from 5 to 15 per centimeter (cm). Blades having lesser number of teeth per cm are used for cutting soft materials like aluminum, brass and bronze. Blades having larger number of teeth per centimeter are used for cutting hard materials like steel and cast Iron.

Hacksaw blades are classified as (i) All hard and (ii) flexible type. The all hard blades are made of H.S.S, hardened and tempered throughout to retain their cutting edges longer. These are used to cut hard metals. These blades are hard and brittle and can break easily by twisting and forcing them into the work while sawing. Flexible blades are made of H.S.S or low alloy steel but only the teeth are hardened and the rest of the blade is soft and flexible. These are suitable for use by un-skilled or semi-skilled persons.

The teeth of the hacksaw blade are staggered, as shown in figure and known as a 'set of teeth'. These make slots wider than the blade thickness, preventing the blade from jamming.

### **Chisels**

Chisels are used for removing surplus metal or for cutting thin sheets. These tools are made from 0.9% to 1.0% carbon steel of octagonal or hexagonal section. Chisels are annealed, hardened and tempered to produce a tough shank and hard cutting edge. Annealing relieves the internal stresses in a metal. The cutting angle of the chisel for general purpose is about 60°.

### **Twist Drill**

Twist drills are used for making holes. These are made of High speed steel. Both straight and taper shank twist drills are used. The parallel shank twist drill can be held in an ordinary self – centering drill check. The taper shank twist drill fits into a corresponding tapered bore provided in the drilling machine spindle.

### **Taps and Tap Wrenches**

A tap is a hardened and steel tool, used for cutting internal thread in a drill hole. Hand Taps are usually supplied in sets of three in each diameter and thread size. Each set consists of a taper tap, intermediate tap and plug or bottoming tap. Taps are made of high carbon steel or high speed steel.

### **Dies and Die Holders**

Dies are the cutting tools used for making external thread. Dies are made either solid or split type. They are fixed in a die stock for holding and adjusting the die gap. They are made of Steel or High Carbon Steel.

### **Bench Drilling Machine**

Holes are drilled for fastening parts with rivets, bolts or for producing internal thread. Bench drilling machine is the most versatile machine used in a fitting shop for the purpose. Twist drills, made of tool steel or high speed steel are used with the drilling machine for drilling holes.

Following are the stages in drilling work

Select the correct size drills, put it into the check and lock it firmly

- Adjust the speed of the machine to suit the work by changing the belt on the pulleys. Use high speed for small drills and soft materials and low speed for large diameter drills and hard materials.
- Layout of the location of the pole and mark it with a center punch.
- Hold the work firmly in the vice on the machine table and clamp it directly on to the machine table. 5. Put on the power, locate the punch mark and apply slight pressure with the Feed Handle.

- Once Drilling is commenced at the correct location, apply enough pressure and continue drilling.
- When drilling steel apply cutting oil at the drilling point.
- Release the pressure slightly, when the drill point pierces the lower surface of the metal. This prevents the drill catching and damaging the work or drill.
- On completion of drilling retrace the drill out of the work and put-off the power supply.

## Finishing Tools

### Reamers

Reaming is an operation of sizing and finishing a drilled hole, with the help of a cutting tool called reamer having a number of cutting edges. For this, a hole is first drilled, the size of which is slightly smaller than the finished size and then a hand reamer or machine reamer is used for finishing the hole to the correct size. Hand Reamer is made of High Carbon

Steel and has left-hand spiral flutes so that, it is prevented from screwing into the whole during operation. The Shank end of the reamer is made straight so that it can be held in a tap wrench. It is operated by hand, with a tap wrench fitted on the square end of the reamer and with the work piece held in the vice. The body of the reamer is given a slight taper at its working end, for its easy entry into the whole during operation, it is rotated only in clock wise direction and also while removing it from the whole.

### Files

Filing is one of the methods of removing small amounts of material from the surface of a metal part. A file is hardened steel too, having small parallel rows of cutting edges or teeth on its surfaces. On the faces, the teeth are usually diagonal to the edge. One end of the file is shaped to fit into a wooden handle. The figure shows various parts of a hand file. The hand file is parallel in width and tapering slightly in thickness, towards the tip. It is provided with double cut teeth. On the faces, single cut on one edge and no teeth on the other edge, this is known as a safe edge.

Files are classified according to their shape, cutting teeth and pitch or grade of the teeth. The figure shows the various types of files based on their shape.

## Finishing Tools

### File Card

It is a metal brush, used for cleaning the files, to free them from filings, clogged in-between the teeth.

### Spirit level

It is used to check the leveling of machines.

**Ball- Peen Hammer**

Ball- Peen Hammers are named, depending upon their shape and material and specified by their weight. A ball peen hammer has a flat face which is used for general work and a ball end, particularly used for riveting.

**Cross-Peen Hammer**

It is similar to ball peen hammer, except the shape of the peen. This is used for chipping, riveting, bending and stretching metals and hammering inside the curves and shoulders.

**Straight-Peen Hammer**

This is similar to cross peen hammer, but its peen is in-line with the hammer handle. It is used for swaging, riveting in restricted places and stretching metals.

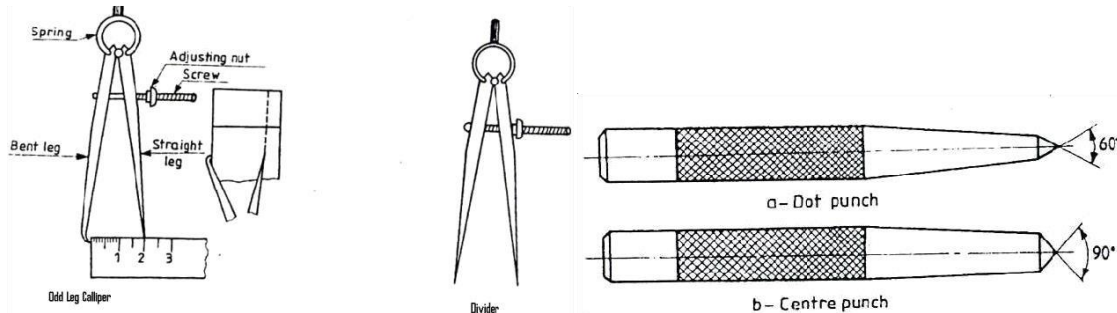
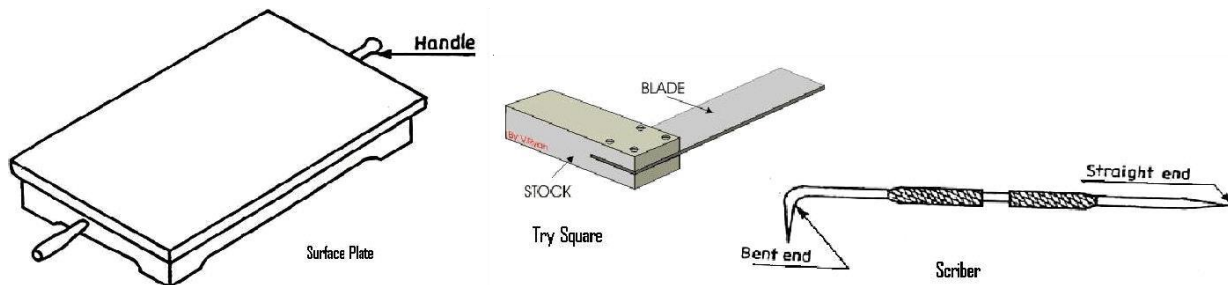
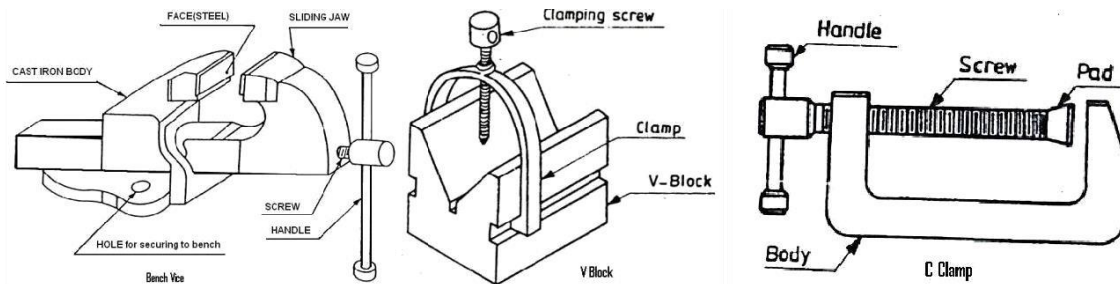



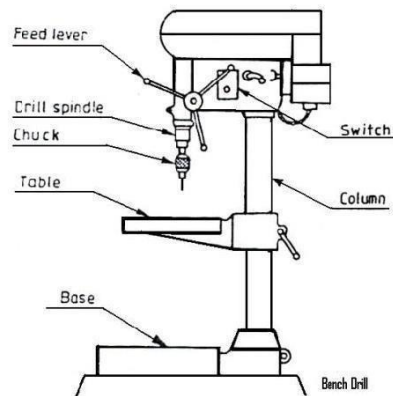
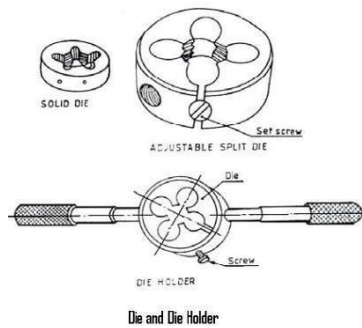
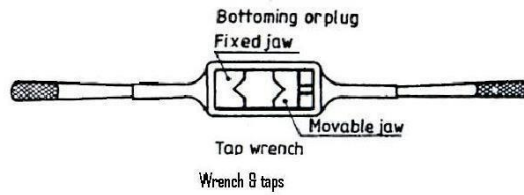
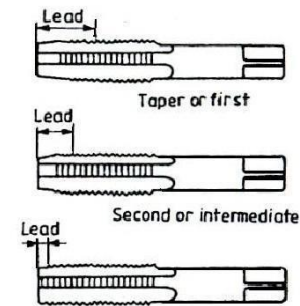
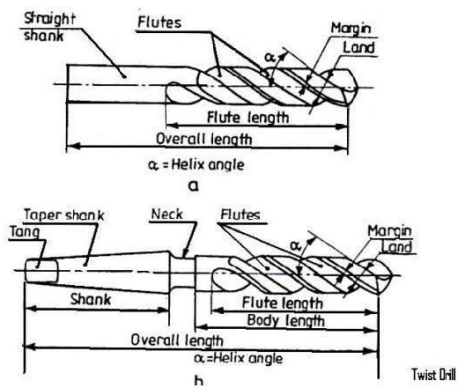
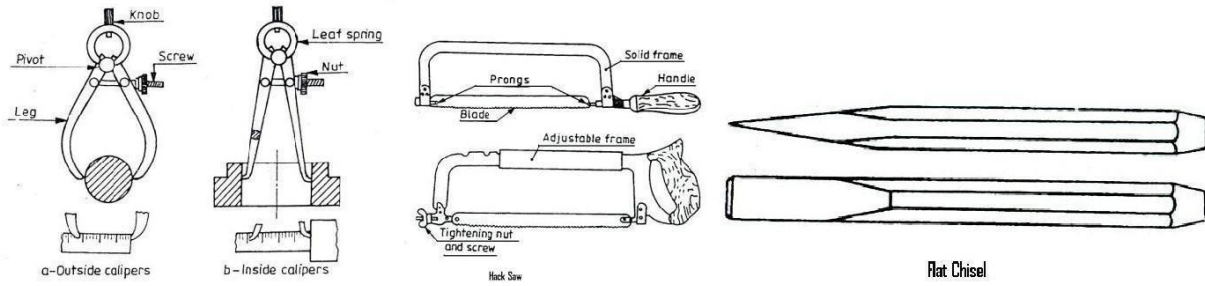

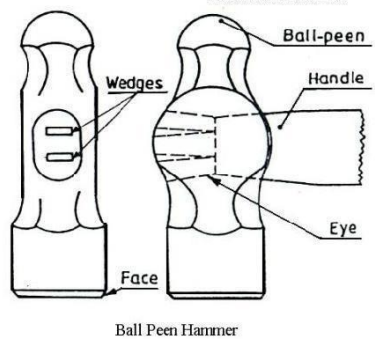
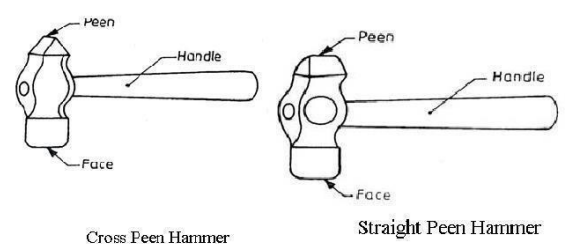
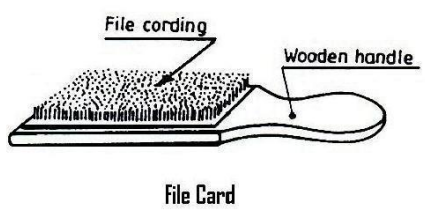
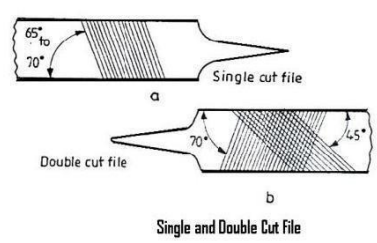
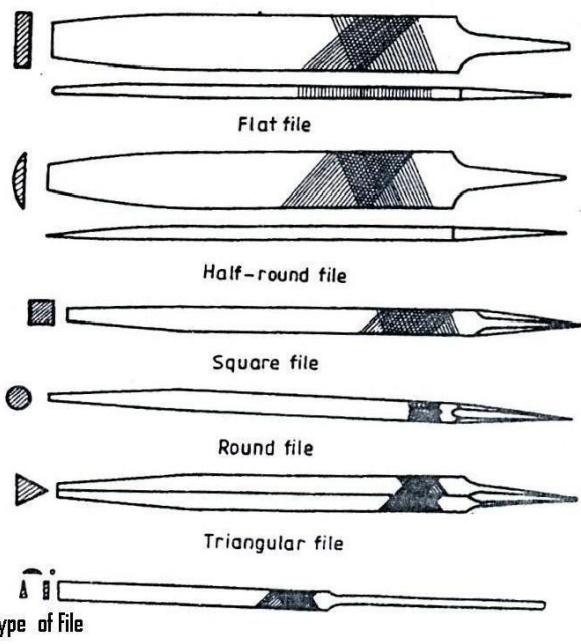
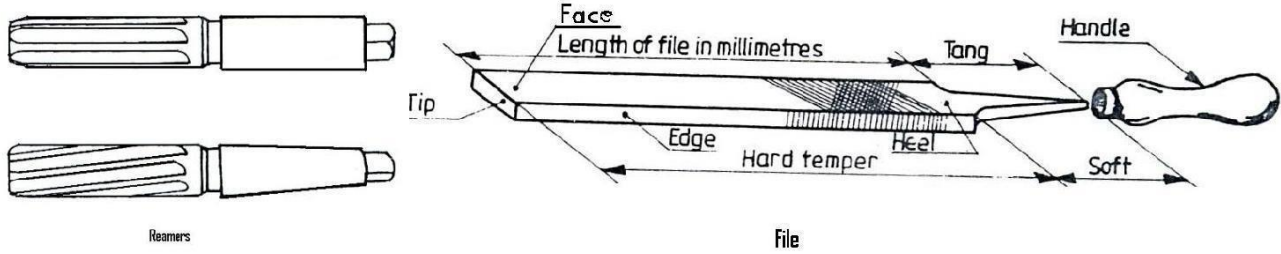

**Exercise 4**

1. What does mean by Bench Work and Fitting?
2. State the different processes done in fitting shop.
3. List the various types of tools used in fitting shop.
4. With the help of neat sketch explain the construction and working of bench vice.
5. List the different types of marking and measuring tools.
6. What are the different types of files? Explain each of them.
7. Sketch and describe hacksaw.
8. Sketch and describe Bench drilling machine.
9. Prepare the fitting job in the Mechanical Workshop as per given drawing.

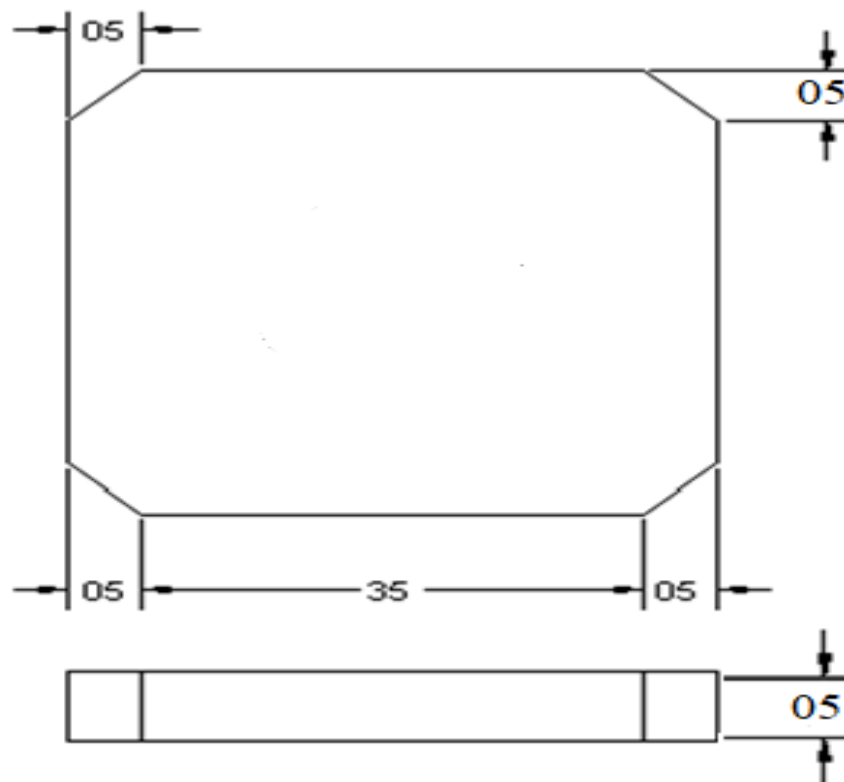
**Fitting Job**

## **PRACTICAL: 5**

### **To study about Tin Smithy shop and preparation of job**

#### **Introduction:**

The metal plank having less than 2mm thick is called sheet metal. Sheet metal work deals with the production of components in wide variety of shapes and sizes with the aid of tools or machines. Some of the important metals used in sheet metal work are described below.

**Galvanized Iron:** It is a sheet of soft steel, which is coated with zinc. Zinc resists corrosion and improves the appearance of the metal galvanized iron in one of the least expensive metals and is used for making pans, buckets, ducts, gutters, tanks, boxes, etc.

**Black Iron:** It is an uncoated sheet of metal with bluish- back appearance. It corrodes rapidly is not expensively due to difficulties of soldering the block iron sheet are used for parts that are to be painted.

**Tin plate:** Tin plate is an iron or steel coated with pure iron. It has very bright silver appearance and is used for food containers, cans, pans.

**Stainless steels:** It is an alloy steel possessing corrosion resistance. General type stainless steel contains 18 percent chromium and 8 percent nickel. This steel is commonly known as 18-8 stainless steel. These are available various sizes and thickness. It is widely used for food containers, dairy equipment.

**Copper:** It has reddish color and possesses good malleability, ductility and resistance to atmospheric corrosion.

**Aluminum:** Sheet aluminum is never pure aluminum and it is always allowed with small quantities of copper silicon, magnesium, and iron.

**Tools and Equipment:** The common hand tools used in sheet metal work are, steel rule, wire gauge, dot punch, trammels, scribe, ball peen hammer, straight –peen hammer, cross peen hammer, Mallets, Snips and Soldering Iron etc.

**Snips:** Hand shear or snips are used to cut sheet metal. Although there are many types, the sheet metal works generally use straight snips and curved snips.

a. **Straight snips:** Straight snips have straight blades and are used for cutting along the straight lines and for trimming edges.

b. **Curved snips:** Curved snips has a curved blade and used for cutting circles and irregular shapes.

**Bench shears:** Bench shear is used for cutting thick sheets. The lower fixed blade is firmly secured by bracket at bottom. The movable blade is pivoted at the rear end; the hand operating lever is attached to the front end of movable blade link mechanism.

**Stakes:** Stakes are made of steel and forged in a variety of shapes and sizes. Its working face is machined and polished to facilitate various operations such as bending, seaming or forming.

The following types of stakes are mostly used.

- a. **Double seaming:** These stakes has two horns and it is used to make double seam for vessels.
- b. **Blow horn:** These stakes have two horn tapering norms and it is used to forming or seaming funnels.
- c. **Break horn:** These stakes have a square tapered horn on one side and a round tapered horn on opposite side. It is used for shaping round and square surfaces, bending edges, and making corners.
- d. **Conductor stake:** These stakes has two cylindrical horns having different diameters. It is used for forming pipes and cylindrical pieces.
- e. **Funnel stake:** It is used for forming conical shapes and for making wire rings.
- f. **Hatchet stake:** It has a horizontal sharp straight edge and can be used for making straight sharp bends and for folding and bending edges.

**Sheet metal joints:** Various types of joints are used in sheet metal work to suit the varying requirements. Some commonly used sheet metal joints and folded edges are shown below. These are self secured joints, formed by joining together 2 pieces of sheet metal and using the metal itself to form the joint.

**Hand Hammers and Mallets:** The sheet metal worker uses a wide variety of hammers and mallet by forming shapes by different operations. The most commonly used hammers are follows.

- a. **Straight-Peen Hammer:** It has a peen end similar to its bottom size round shape and its top side is straight point. Square, slightly curved face and its peen is tapered, it is used for riveting.
- b. **Cross Peen Hammer:** It has a square flat face and it is tapered on one side. It is used for setting down the edges for making a double seam.
- c. **Mallet:** Mallet is generally made of wood and plastic. It is used whenever slight blows are required. Wooden mallets don't damage the surface.

**Safety precautions:**

Never carry tools on pockets.

Do not try to hold the sheets with bare hands. Do not remove any guards on squaring shears. ☒

Care should be exercised when working on squaring shears.

Be sure that the fingers are away from the shearing blade.

**Exercise 5**

- ☒ Enlist the equipments and operations of tin smithy shop.
- ☒ To Prepare a Tin Smithy job as per the drawing given below.
- ☒
- ☒
- ☒

### Tin Smithy Job\_ OPEN SCOOP

**Aim:** To make an open scoop as per the given dimensions.

**Tools required:** 300mm steel rule, try square, divider, scribe, straight snip, mallet, ball peen hammer and hatchet stake.

**Sequence of operation:**

1. The size of the given sheet is checked with the steel rule.
2. The layout of the Open scoop is drawn in the sheet and cut as shown in the development.
3. Single hemming is made on the two sides of the scoop.
4. The two sides of the scoop are bent to 90°.
5. Finally the third side is bent to 90° and seaming operation is done to obtain the open scoop.

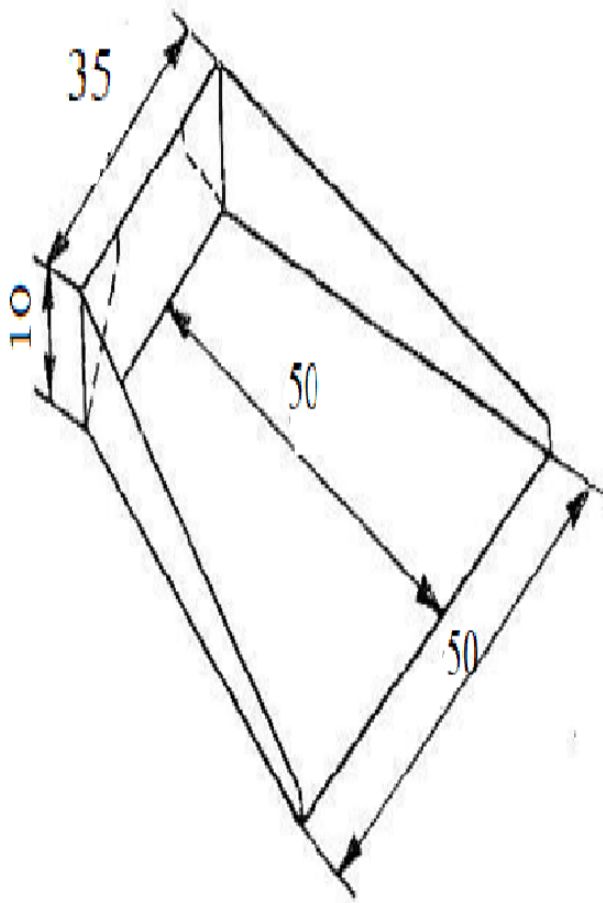

**Open Scoop**

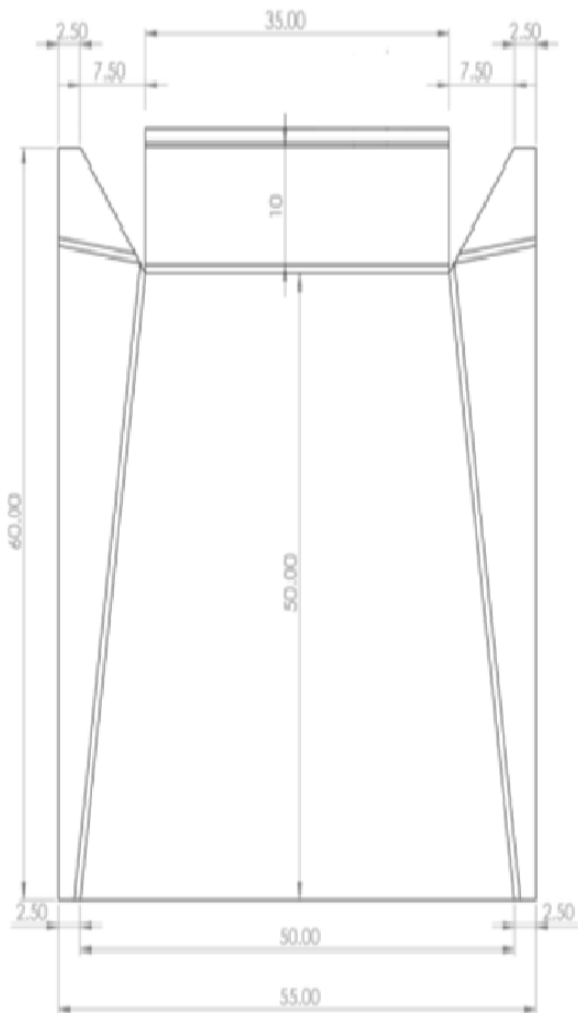

**Development**

**Precautions:**

1. Do not try to hold the sheets with bare hands.

2. Be sure that the fingers are away from the shearing bend.
3. Markings should be done carefully.
4. Cutting should be done carefully to avoid cross cutting.

**Result:**

The Open scoop is thus made, from the given sheet metal as per dimensions.