

MICROPROCESSOR 8085

- Reference Book:
 - Ramesh S. Goankar, “Microprocessor Architecture, Programming and Applications with 8085”, 5th Edition, Prentice Hall
- Week 1 – Basic Concept and Ideas about Microprocessor.
- Week 2 - Architecture of 8085
- Week 3 - Addressing Modes and Instruction set of 8085
- Week 4 – Interrupts of 8085
- Week 5 onwards – Peripherals.

Basic Concepts of Microprocessors

- Differences between:
 - Microcomputer – a computer with a microprocessor as its CPU. Includes memory, I/O etc.
 - Microprocessor – silicon chip which includes ALU, register circuits & control circuits
 - Microcontroller – silicon chip which includes microprocessor, memory & I/O in a single package.

What is a Microprocessor?

- The word comes from the combination micro and processor.
 - Processor means a device that processes whatever. In this context processor means a device that processes numbers, specifically binary numbers, 0's and 1's.
 - To process means to manipulate. It is a general term that describes all manipulation. Again in this content, it means to perform certain operations on the numbers that depend on the microprocessor's design.

What about micro?

- Micro is a new addition.
 - In the late 1960's, processors were built using discrete elements.
 - These devices performed the required operation, but were too large and too slow.
 - In the early 1970's the microchip was invented. All of the components that made up the processor were now placed on a single piece of silicon. The size became several thousand times smaller and the speed became several hundred times faster. The “Micro”Processor was born.

Was there ever a “mini”-processor?

- No.
 - It went directly from discrete elements to a single chip. However, comparing today’s microprocessors to the ones built in the early 1970’s you find an extreme increase in the amount of integration.
- So, What is a microprocessor?

Definition of the Microprocessor

The microprocessor is a programmable device that takes in numbers, performs on them arithmetic or logical operations according to the program stored in memory and then produces other numbers as a result.

Definition (Contd.)

- Lets expand each of the underlined words:
 - **Programmable device**: The microprocessor can perform different sets of operations on the data it receives depending on the sequence of instructions supplied in the given program.
By changing the program, the microprocessor manipulates the data in different ways.
 - **Instructions**: Each microprocessor is designed to execute a specific group of operations. This group of operations is called an instruction set. This instruction set defines what the microprocessor can and cannot do.

Definition (Contd.)

- **Takes in:** The data that the microprocessor manipulates must come from somewhere.
 - It comes from what is called “input devices”.
 - These are devices that bring data into the system from the outside world.
 - These represent devices such as a keyboard, a mouse, switches, and the like.

Definition (Contd.)

- **Numbers:** The microprocessor has a very narrow view on life. It only understands binary numbers.

A binary digit is called a bit (which comes from binary digit).

The microprocessor recognizes and processes a group of bits together. This group of bits is called a “word”.

The number of bits in a Microprocessor’s word, is a measure of its “abilities”.

Definition (Contd.)

– Words, Bytes, etc.

- The earliest microprocessor (the Intel 8088 and Motorola's 6800) recognized 8-bit words.
 - They processed information 8-bits at a time. That's why they are called "8-bit processors". They can handle large numbers, but in order to process these numbers, they broke them into 8-bit pieces and processed each group of 8-bits separately.
- Later microprocessors (8086 and 68000) were designed with 16-bit **words**.
 - A group of 8-bits were referred to as a "half-word" or "byte".
 - A group of 4 bits is called a "nibble".
 - Also, 32 bit groups were given the name "long word".
- Today, all processors manipulate at least 32 bits at a time and there exists microprocessors that can process 64, 80, 128 bits

Definition (Contd.)

– Arithmetic and Logic Operations:

- Every microprocessor has arithmetic operations such as add and subtract as part of its instruction set.
 - Most microprocessors will have operations such as multiply and divide.
 - Some of the newer ones will have complex operations such as square root.
- In addition, microprocessors have logic operations as well. Such as AND, OR, XOR, shift left, shift right, etc.
- Again, the number and types of operations define the microprocessor's instruction set and depends on the specific microprocessor.

Definition (Contd.)

– Stored in memory :

- First, what is memory?
 - Memory is the location where information is kept while not in current use.
 - Memory is a collection of storage devices. Usually, each storage device holds one bit. Also, in most kinds of memory, these storage devices are grouped into groups of 8. These 8 storage locations can only be accessed together. So, one can only read or write in terms of bytes to and from memory.
 - Memory is usually measured by the number of bytes it can hold. It is measured in Kilos, Megas and lately Gigas. A Kilo in computer language is $2^{10}=1024$. So, a KB (KiloByte) is 1024 bytes. Mega is 1024 Kilos and Giga is 1024 Mega.

Definition (Contd.)

– Stored in memory:

- When a program is entered into a computer, it is stored in memory. Then as the microprocessor starts to execute the instructions, it brings the instructions from memory one at a time.
- Memory is also used to hold the data.
 - The microprocessor reads (brings in) the data from memory when it needs it and writes (stores) the results into memory when it is done.

Definition (Contd.)

- **Produces:** For the user to see the result of the execution of the program, the results must be presented in a human readable form.
 - The results must be presented on an output device.
 - This can be the monitor, a paper from the printer, a simple LED or many other forms.

A Microprocessor-based system

From the above description, we can draw the following block diagram to represent a microprocessor-based system:

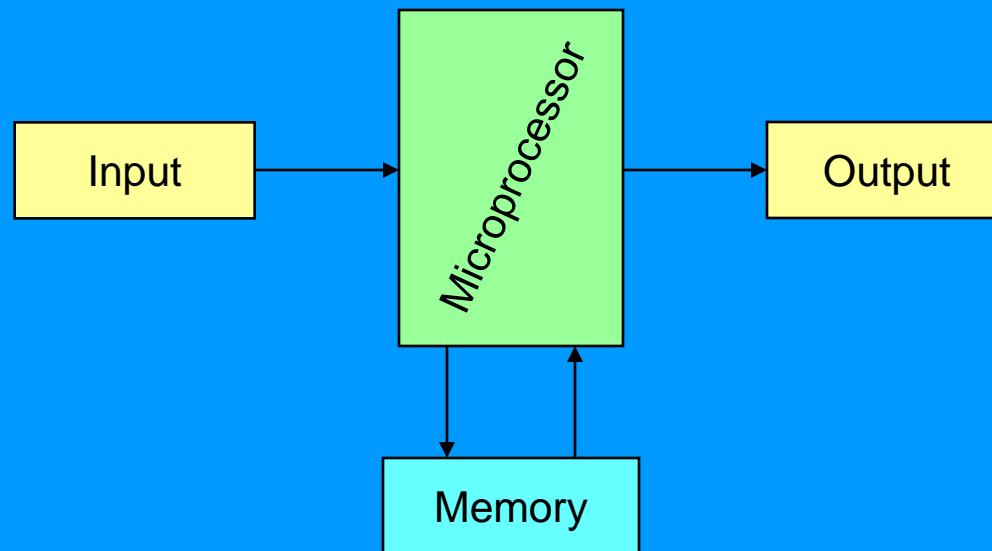

Inside The Microprocessor

- Internally, the microprocessor is made up of 3 main units.
 - The Arithmetic/Logic Unit (ALU)
 - The Control Unit.
 - An array of registers for holding data while it is being manipulated.

Organization of a microprocessor-based system

- Let's expand the picture a bit.

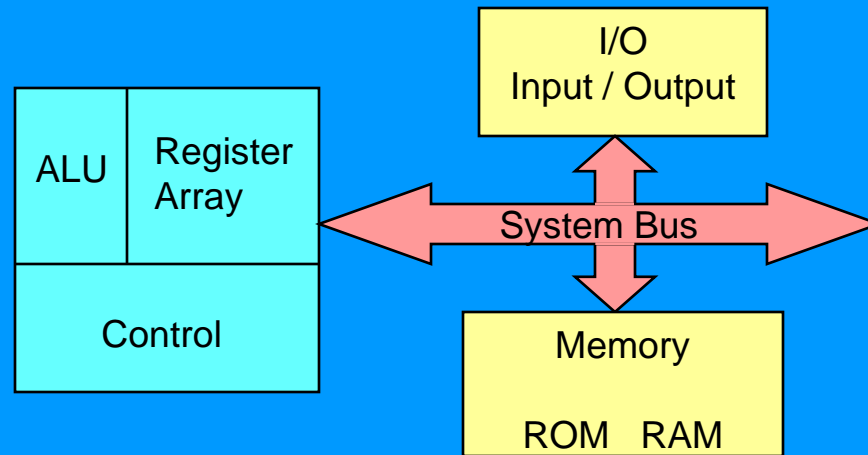

Memory

- Memory stores information such as instructions and data in binary format (0 and 1). It provides this information to the microprocessor whenever it is needed.
- Usually, there is a memory “sub-system” in a microprocessor-based system. This sub-system includes:
 - The registers inside the microprocessor
 - Read Only Memory (ROM)
 - used to store information that does not change.
 - Random Access Memory (RAM) (also known as Read/Write Memory).
 - used to store information supplied by the user. Such as programs and data.

Memory Map and Addresses

- The memory map is a picture representation of the address range and shows where the different memory chips are located within the address range.

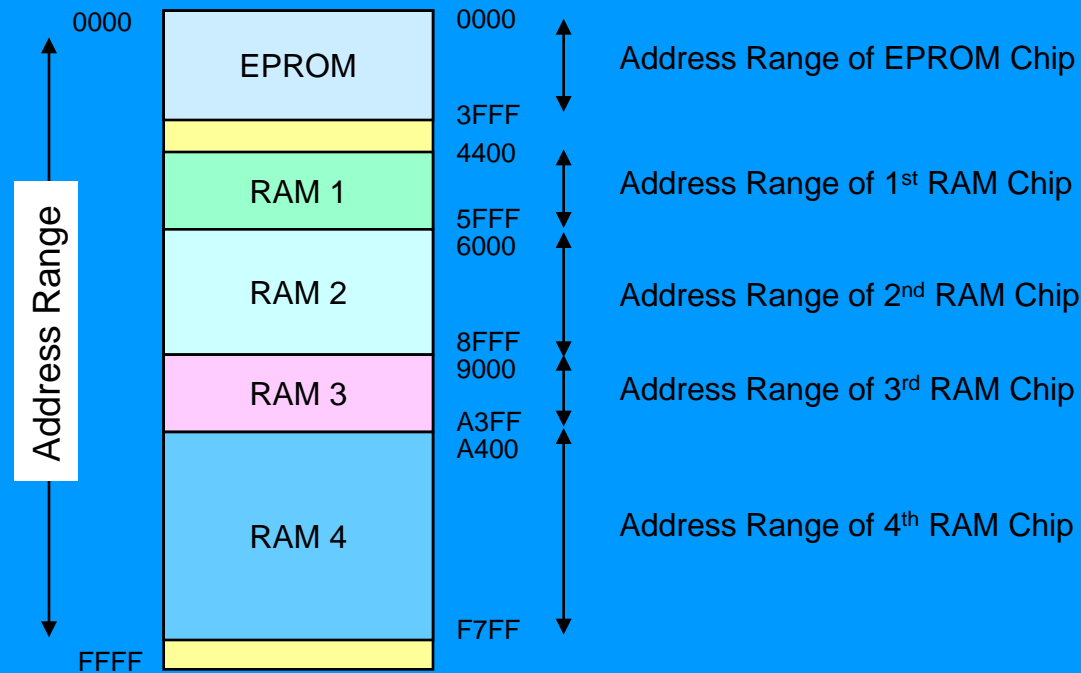

Memory

- To execute a program:
 - the user enters its instructions in binary format into the memory.
 - The microprocessor then reads these instructions and whatever data is needed from memory, executes the instructions and places the results either in memory or produces it on an output device.

The three cycle instruction execution model

- To execute a program, the microprocessor “reads” each instruction from memory, “interprets” it, then “executes” it.
- To use the right names for the cycles:
 - The microprocessor **fetches** each instruction,
 - **decodes** it,
 - Then **executes** it.
- This sequence is continued until all instructions are performed.

Machine Language

- The number of bits that form the “word” of a microprocessor is fixed for that particular processor.
 - These bits define a maximum number of combinations.
 - For example an 8-bit microprocessor can have at most $2^8 = 256$ different combinations.
- However, in most microprocessors, not all of these combinations are used.
 - Certain patterns are chosen and assigned specific meanings.
 - Each of these patterns forms an instruction for the microprocessor.
 - The complete set of patterns makes up the microprocessor’s machine language.

The 8085 Machine Language

- The 8085 (from Intel) is an 8-bit microprocessor.
 - The 8085 uses a total of 246 bit patterns to form its instruction set.
 - These 246 patterns represent only 74 instructions.
 - The reason for the difference is that some (actually most) instructions have multiple different formats.
 - Because it is very difficult to enter the bit patterns correctly, they are usually entered in hexadecimal instead of binary.
 - For example, the combination 0011 1100 which translates into “increment the number in the register called the accumulator”, is usually entered as 3C.

Assembly Language

- Entering the instructions using hexadecimal is quite easier than entering the binary combinations.
 - However, it still is difficult to understand what a program written in hexadecimal does.
 - So, each company defines a symbolic code for the instructions.
 - These codes are called “mnemonics”.
 - The mnemonic for each instruction is usually a group of letters that suggest the operation performed.

Assembly Language

- Using the same example from before,
 - 00111100 translates to 3C in hexadecimal (OPCODE)
 - Its mnemonic is: “INR A”.
 - INR stands for “increment register” and A is short for accumulator.
- Another example is: 1000 0000,
 - Which translates to 80 in hexadecimal.
 - Its mnemonic is “ADD B”.
 - “Add register B to the accumulator and keep the result in the accumulator”.

Assembly Language

- It is important to remember that a machine language and its associated assembly language are completely machine dependent.
 - In other words, they are not transferable from one microprocessor to a different one.
- For example, Motorola has an 8-bit microprocessor called the 6800.
 - The 8085 machine language is very different from that of the 6800. So is the assembly language.
 - A program written for the 8085 cannot be executed on the 6800 and vice versa.

“Assembling” The Program

- How does assembly language get translated into machine language?
 - There are two ways:
 - 1st there is “**hand assembly**”.
 - The programmer translates each assembly language instruction into its equivalent hexadecimal code (machine language). Then the hexadecimal code is entered into memory.
 - The other possibility is a program called an “**assembler**”, which does the translation automatically.

8085 Microprocessor Architecture

- 8-bit general purpose μ p
- Capable of addressing 64 k of memory
- Has 40 pins
- Requires +5 v power supply
- Can operate with 3 MHz clock
- 8085 upward compatible

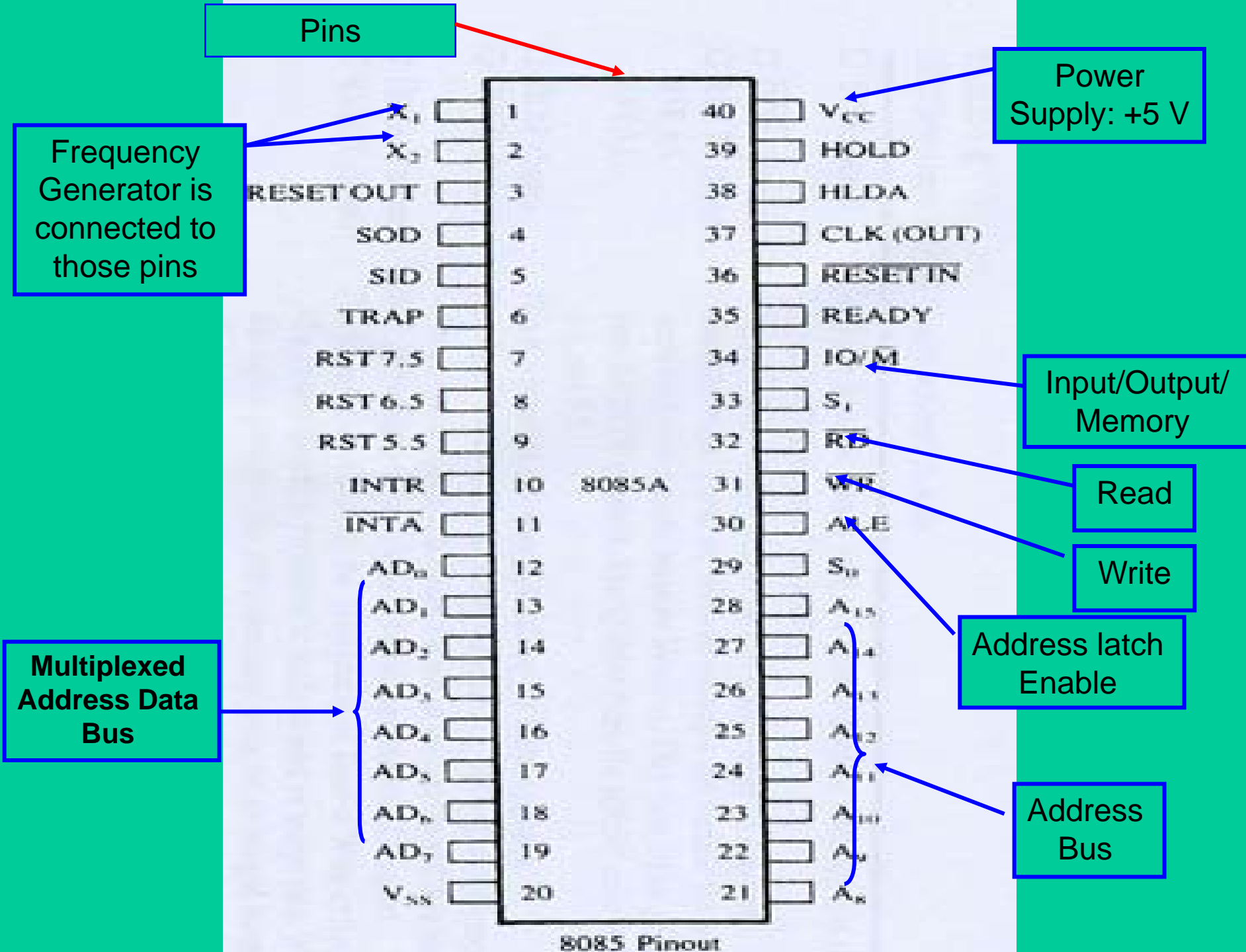

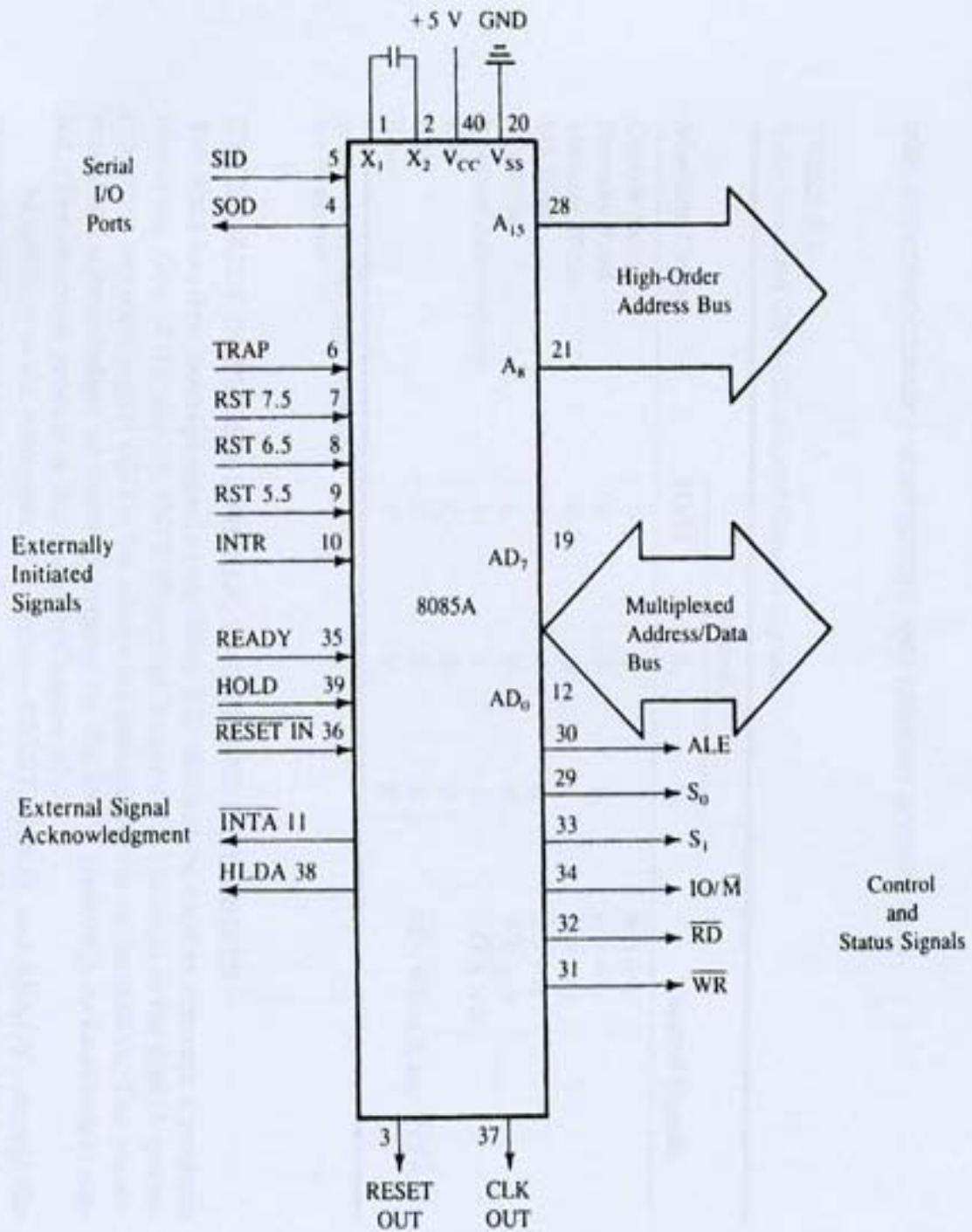

- System Bus – wires connecting memory & I/O to microprocessor
 - Address Bus
 - Unidirectional
 - Identifying peripheral or memory location
 - Data Bus
 - Bidirectional
 - Transferring data
 - Control Bus
 - Synchronization signals
 - Timing signals
 - Control signal

Architecture of Intel 8085 Microprocessor

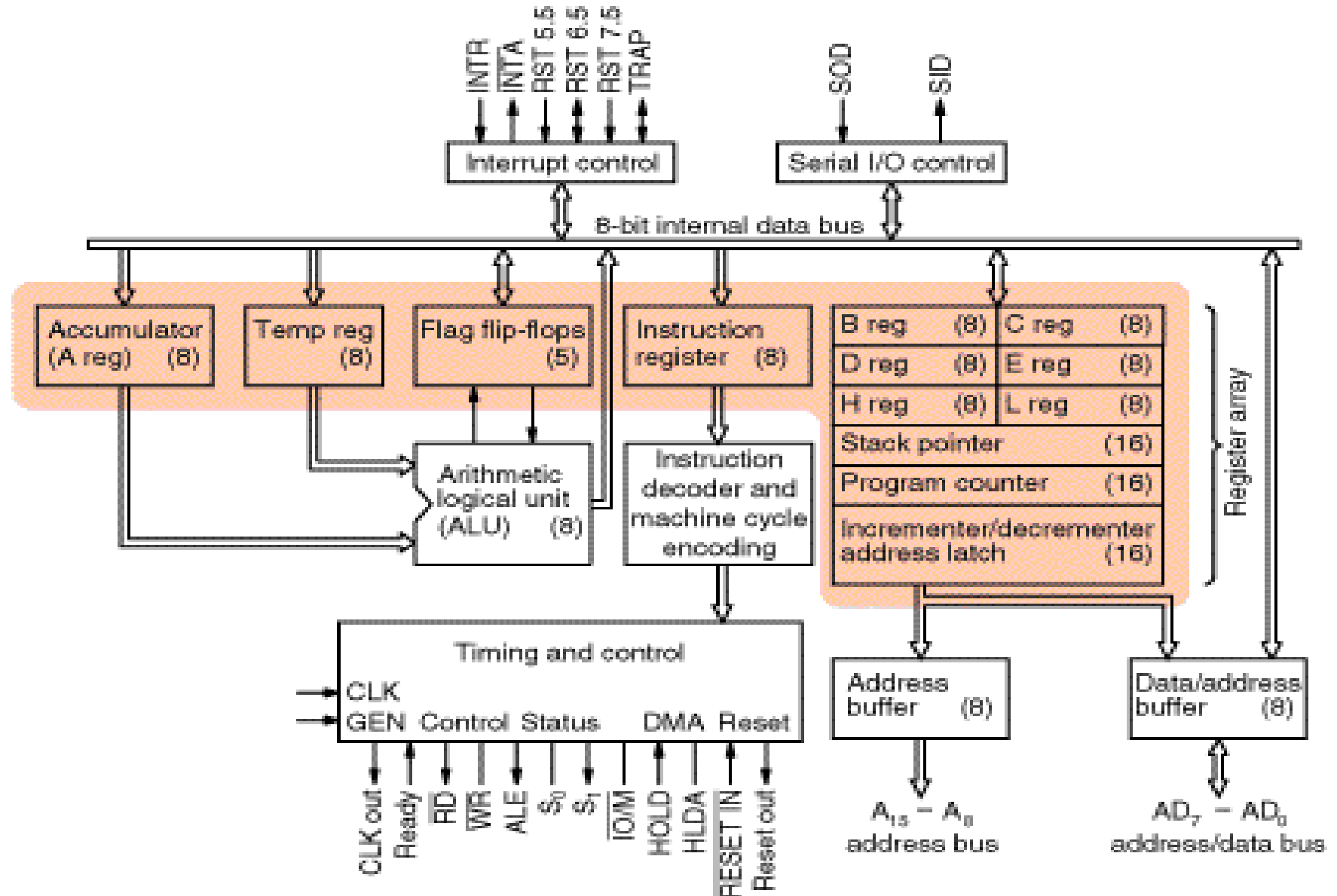

Intel 8085 Microprocessor

- Microprocessor consists of:
 - **Control unit**: control microprocessor operations.
 - **ALU**: performs data processing function.
 - **Registers**: provide storage internal to CPU.
 - **Interrupts**
 - **Internal data bus**

The ALU

- In addition to the arithmetic & logic circuits, the ALU includes the accumulator, which is part of every arithmetic & logic operation.
- Also, the ALU includes a temporary register used for holding data temporarily during the execution of the operation. This temporary register is not accessible by the programmer.

- Registers

- General Purpose Registers

- **B, C, D, E, H & L** (8 bit registers)
 - Can be used singly
 - Or can be used as 16 bit register pairs
 - BC, DE, HL
 - H & L can be used as a data pointer (holds memory address)

- Special Purpose Registers

- **Accumulator** (8 bit register)
 - Store 8 bit data
 - Store the result of an operation
 - Store 8 bit data during I/O transfer

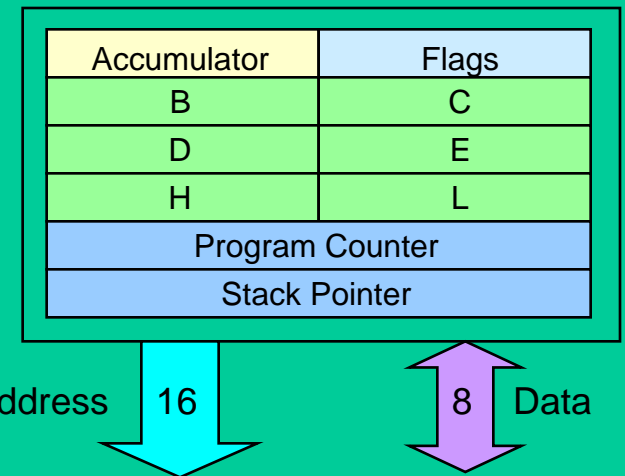

- **Flag Register**

- 8 bit register – shows the status of the microprocessor before/after an operation
- S (sign flag), Z (zero flag), AC (auxillary carry flag), P (parity flag) & CY (carry flag)

D7	D6	D5	D4	D3	D2	D1	D0
S	Z	X	AC	X	P	X	CY

- Sign Flag

- Used for indicating the sign of the data in the accumulator
- The sign flag is set if negative (1 – negative)
- The sign flag is reset if positive (0 –positive)

- Zero Flag

- Is set if result obtained after an operation is 0
- Is set following an increment or decrement operation of that register

$$\begin{array}{r} 10110011 \\ + 01001101 \\ \hline 1\ 00000000 \end{array}$$

- Carry Flag

- Is set if there is a carry or borrow from arithmetic operation

$$\begin{array}{r} 1011\ 0101 \\ + 0110\ 1100 \\ \hline \text{Carry 1}\ 0010\ 0001 \end{array}$$

$$\begin{array}{r} 1011\ 0101 \\ - 1100\ 1100 \\ \hline \text{Borrow 1}\ 1110\ 1001 \end{array}$$

- Auxillary Carry Flag
 - Is set if there is a carry out of bit 3
- Parity Flag
 - Is set if parity is even
 - Is cleared if parity is odd

The Internal Architecture

- We have already discussed the general purpose registers, the Accumulator, and the flags.
- The Program Counter (PC)
 - This is a register that is used to control the sequencing of the execution of instructions.
 - This register always holds the address of the next instruction.
 - Since it holds an address, it must be 16 bits wide.

The Internal Architecture

- The Stack pointer
 - The stack pointer is also a 16-bit register that is used to point into memory.
 - The memory this register points to is a special area called the stack.
 - The stack is an area of memory used to hold data that will be retrieved soon.
 - The stack is usually accessed in a Last In First Out (LIFO) fashion.

Non Programmable Registers

- **Instruction Register & Decoder**
 - Instruction is stored in IR after fetched by processor
 - Decoder decodes instruction in IR

Internal Clock generator

- 3.125 MHz internally
- 6.25 MHz externally

The Address and Data Busses

- The address bus has 8 signal lines **A8 – A15** which are **unidirectional**.
- The other 8 address bits are **multiplexed** (time shared) **with the 8 data bits**.
 - So, the bits **AD0 – AD7** are **bi-directional** and serve as **A0 – A7** and **D0 – D7** at the same time.
 - During the execution of the instruction, these lines carry the address bits during the early part, then during the late parts of the execution, they carry the 8 data bits.
 - In order to separate the address from the data, we can use a latch to save the value before the function of the bits changes.

Demultiplexing AD7-AD0

- From the above description, it becomes obvious that the **AD7– AD0** lines are serving a **dual purpose** and that they need to be demultiplexed to get all the information.
- The **high order bits** of the address remain on the bus for **three clock periods**. However, the **low order bits** remain for **only one clock period** and they would be lost if they are not saved externally. Also, notice that the **low order bits** of the address **disappear** when they are needed most.
- To make sure we have the entire address for the full three clock cycles, we will use an **external latch** to save the value of AD7– AD0 when it is carrying the address bits. We use the **ALE** signal to enable this latch.

Demultiplexing AD7-AD0

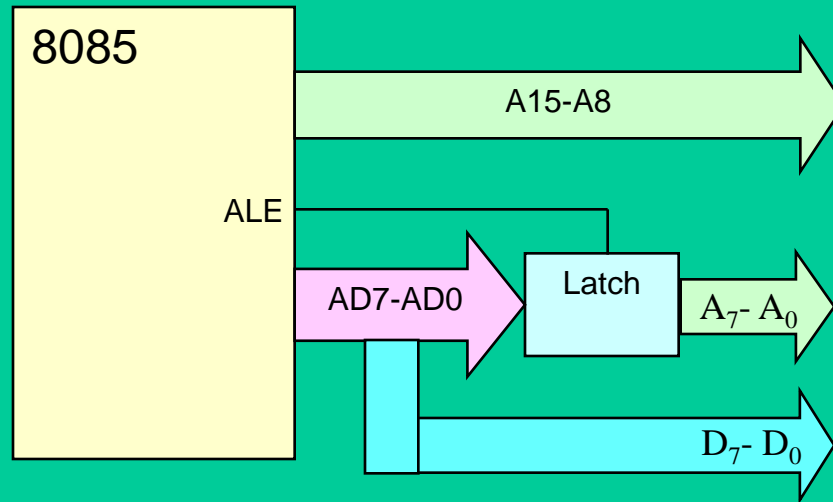

- Given that ALE operates as a pulse during T1, we will be able to latch the address. Then when ALE goes low, the address is saved and the AD7– AD0 lines can be used for their purpose as the bi-directional data lines.

Demultiplexing the Bus $AD_7 - AD_0$

- The high order address is placed on the address bus and hold for 3 clk periods,
- The low order address is lost after the first clk period, this address needs to be hold however we need to use latch
- The address $AD_7 - AD_0$ is connected as inputs to the latch 74LS373.
- The ALE signal is connected to the enable (G) pin of the latch and the OC – Output control – of the latch is grounded

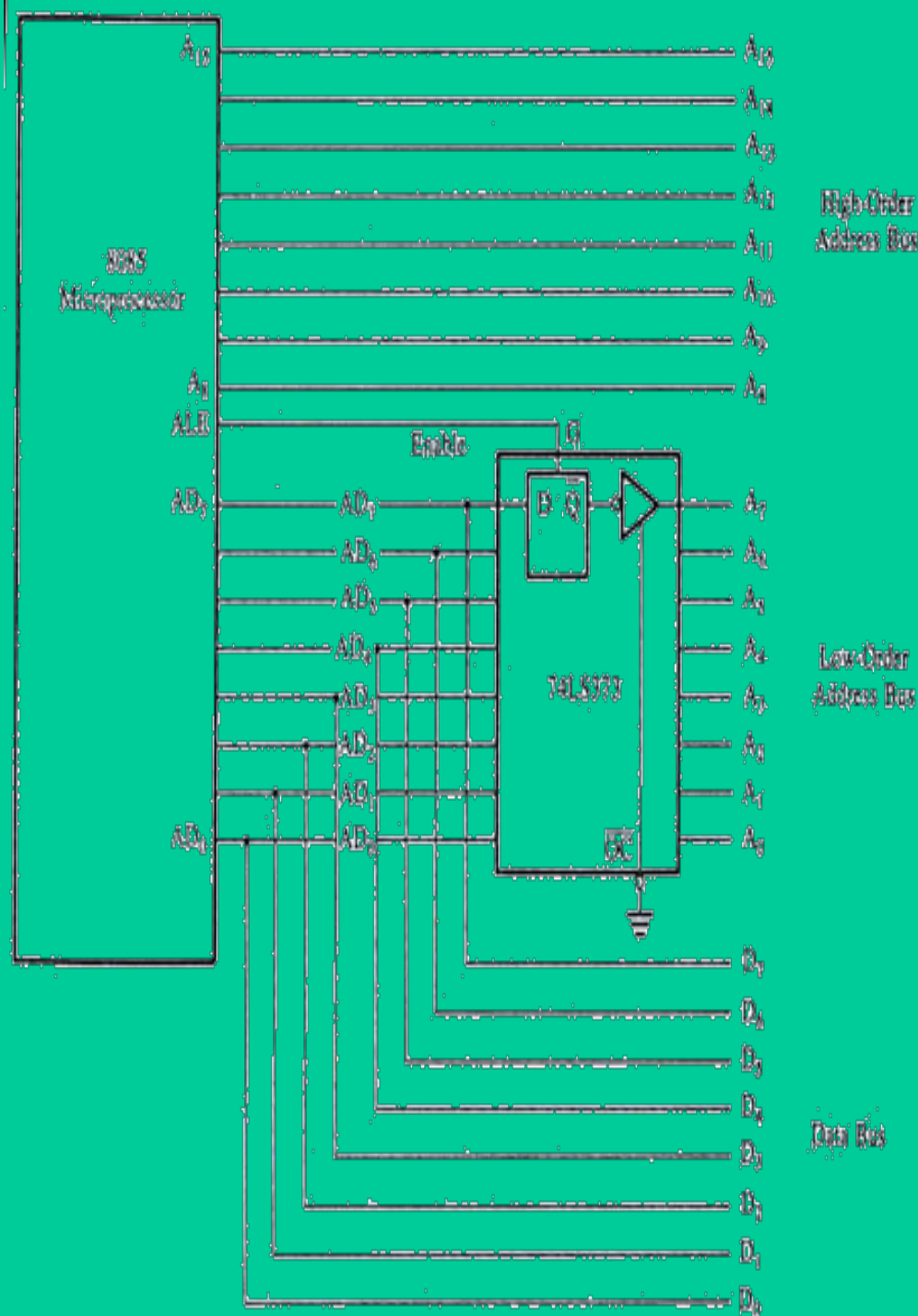

The Overall Picture

- Putting all of the concepts together, we get:

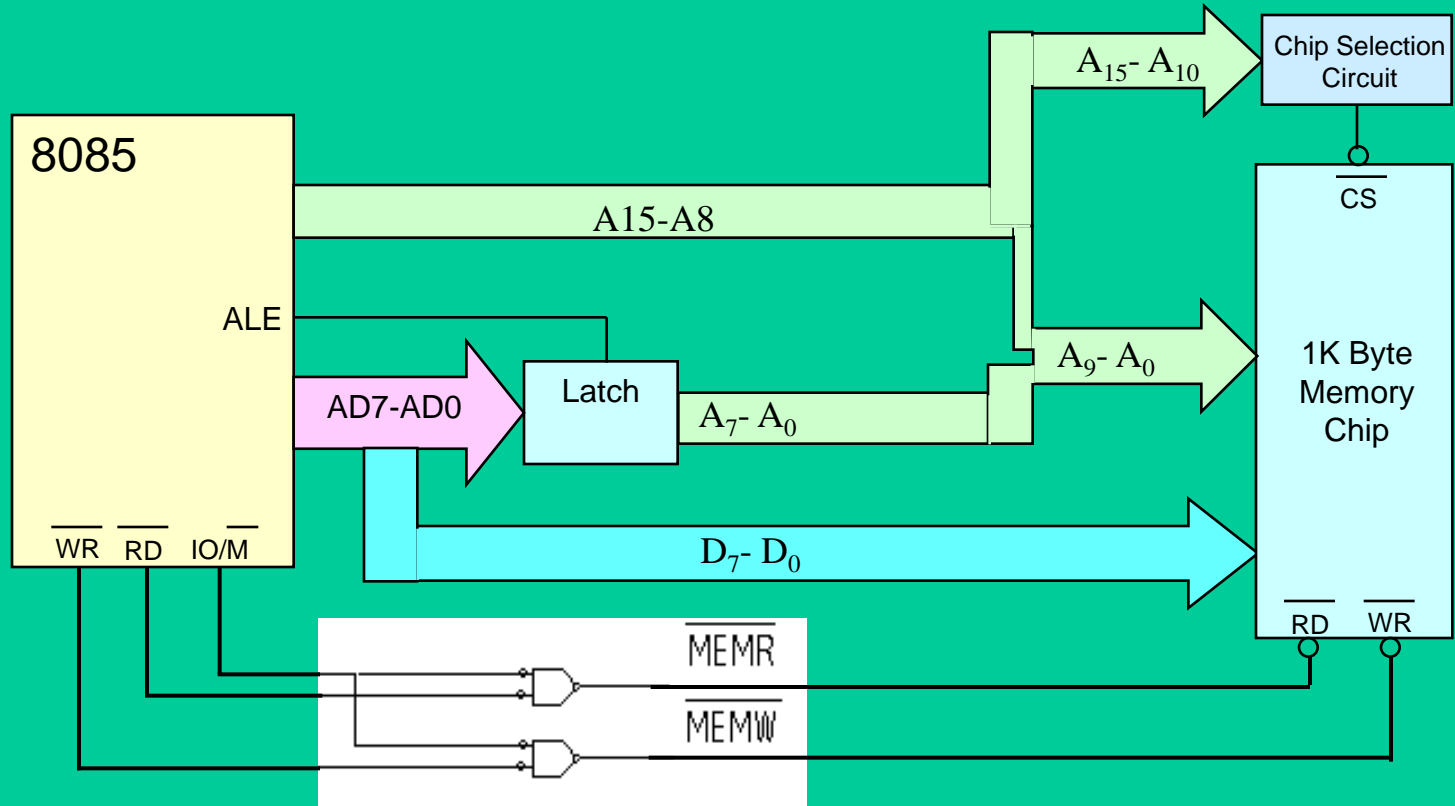

Introduction to 8085 Instructions

The 8085 Instructions

- Since the 8085 is an 8-bit device it can have up to 2^8 (256) instructions.
 - However, the 8085 only uses 246 combinations that represent a total of 74 instructions.
 - Most of the instructions have more than one format.
- These instructions can be grouped into five different groups:
 - Data Transfer Operations
 - Arithmetic Operations
 - Logic Operations
 - Branch Operations
 - Machine Control Operations

Instruction and Data Formats

- Each instruction has two parts.
 - The first part is the task or operation to be performed.
 - This part is called the “opcode” (operation code).
 - The second part is the data to be operated on
 - Called the “operand”.

Data Transfer Operations

- These operations simply **COPY** the data from the source to the destination.
- MOV, MVI, LDA, and STA
- They transfer:
 - Data between registers.
 - Data Byte to a register or memory location.
 - Data between a memory location and a register.
 - Data between an I\O Device and the accumulator.
- The data in the source is **not changed**.

The LXI instruction

- The 8085 provides an instruction to place the 16-bit data into the register pair in one step.

- **LXI Rp, <16-bit address>** (Load eXtended ImmEDIATE)

– The instruction **LXI B 4000H** will place the 16-bit number 4000 into the register pair B, C.

- The upper two digits are placed in the 1st register of the pair and the lower two digits in the 2nd.

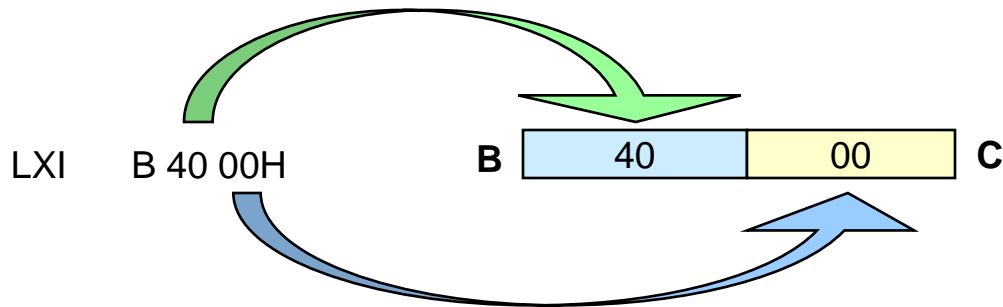

The Memory “Register”

- Most of the instructions of the 8085 can use a memory location in place of a register.
 - The memory location will become the “**memory**” register **M**.
 - **MOV M B**
 - copy the data from register B into a memory location.
 - Which memory location?
- The memory location is identified by the contents of the HL register pair.
 - The 16-bit contents of the HL register pair are treated as a 16-bit address and used to identify the memory location.

Using the Other Register Pairs

- There is also an instruction for moving data from memory to the accumulator without disturbing the contents of the H and L register.

- **LDAX Rp** (LoAd Accumulator eXtended)

- Copy the 8-bit contents of the memory location identified by the Rp register pair into the Accumulator.
- This instruction only uses the **BC** or **DE** pair.
- It does not accept the **HL** pair.

Indirect Addressing Mode

- Using data in memory directly (without loading first into a Microprocessor's register) is called **Indirect Addressing**.
- Indirect addressing uses the data in a register pair as a 16-bit address to identify the memory location being accessed.
 - The HL register pair is always used in conjunction with the memory register “M”.
 - The BC and DE register pairs can be used to load data into the Accumulator using indirect addressing.

Arithmetic Operations

- Addition (ADD, ADI):
 - Any 8-bit number.
 - The contents of a register.
 - The contents of a memory location.
 - Can be added to the contents of the accumulator and the **result is stored in the accumulator.**
- Subtraction (SUB, SUI):
 - Any 8-bit number
 - The contents of a register
 - The contents of a memory location
 - Can be subtracted **from** the contents of the accumulator. **The result is stored in the accumulator.**

Arithmetic Operations Related to Memory

- These instructions perform an arithmetic operation using the contents of a memory location while they are still in memory.
 - ADD M
 - Add the contents of M to the Accumulator
 - SUB M
 - Sub the contents of M from the Accumulator
 - INR M / DCR M
 - Increment/decrement the contents of the memory location in place.
 - All of these use the contents of the HL register pair to identify the memory location being used.

Arithmetic Operations

- Increment (INR) and Decrement (DCR):
 - The 8-bit contents of any memory location or any register can be directly incremented or decremented by 1.
 - No need to disturb the contents of the accumulator.

Manipulating Addresses

- Now that we have a 16-bit address in a register pair, how do we manipulate it?
 - It is possible to manipulate a 16-bit address stored in a register pair as one entity using some special instructions.
 - **INX Rp** (Increment the 16-bit number in the register pair)
 - **DCX Rp** (Decrement the 16-bit number in the register pair)
 - The register pair is incremented or decremented as one entity. No need to worry about a carry from the lower 8-bits to the upper. It is taken care of automatically.

Logic Operations

- These instructions perform logic operations on the contents of the accumulator.
 - ANA, ANI, ORA, ORI, XRA and XRI
 - Source: Accumulator and
 - An 8-bit number
 - The contents of a register
 - The contents of a memory location
 - Destination: Accumulator

ANA R/M

ANI #

ORA R/M

ORI #

XRA R/M

XRI #

AND Accumulator With Reg/Mem

AND Accumulator With an 8-bit number

OR Accumulator With Reg/Mem

OR Accumulator With an 8-bit number

XOR Accumulator With Reg/Mem

XOR Accumulator With an 8-bit number

Logic Operations

– Complement:

- 1's complement of the contents of the accumulator.

CMA No operand

Additional Logic Operations

- Rotate
 - Rotate the contents of the accumulator one position to the left or right.
 - RLC Rotate the accumulator left.
Bit 7 goes to **bit 0 AND** the **Carry flag**.
 - RAL Rotate the accumulator left through the carry.
Bit 7 goes to **the carry** and **carry** goes to **bit 0**.
 - RRC Rotate the accumulator right.
Bit 0 goes to **bit 7 AND** the **Carry flag**.
 - RAR Rotate the accumulator right through the carry.
Bit 0 goes to **the carry** and **carry** goes to **bit 7**.

RLC vs. RLA

- RLC

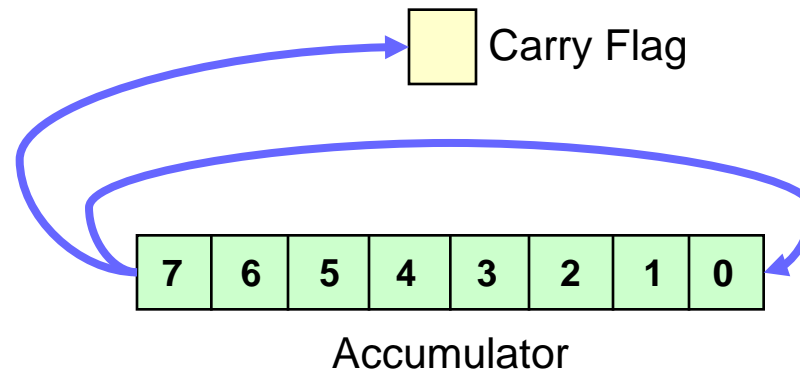

- RAL

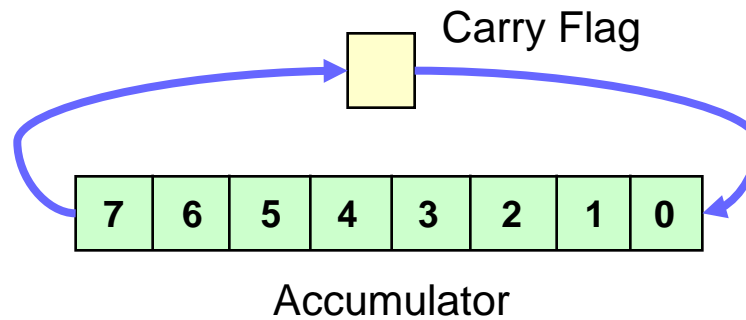

Logical Operations

- Compare

- Compare the contents of a register or memory location with the contents of the accumulator.

- CMP R/M Compare the contents of the register or memory location to the contents of the accumulator.

- CPI # Compare the 8-bit number to the contents of the accumulator.

- The compare instruction sets the flags (Z, Cy, and S).
- The compare is done using an internal subtraction that does not change the contents of the accumulator.

- A – (R / M / #)

Branch Operations

- Two types:
 - Unconditional branch.
 - Go to a new location no matter what.
 - Conditional branch.
 - Go to a new location if the condition is true.

Unconditional Branch

- **JMP** Address
 - Jump to the address specified (Go to).
- **CALL** Address
 - Jump to the address specified but treat it as a subroutine.
- **RET**
 - Return from a subroutine.
- The addresses supplied to all branch operations must be **16-bits**.

Conditional Branch

- Go to new location if a specified condition is met.
 - JZ Address (Jump on Zero)
 - Go to address specified if the **Zero flag is set.**
 - JNZ Address (Jump on NOT Zero)
 - Go to address specified if the **Zero flag is not set.**
 - JC Address (Jump on Carry)
 - Go to the address specified if the **Carry flag is set.**
 - JNC Address (Jump on No Carry)
 - Go to the address specified if the **Carry flag is not set.**
 - JP Address (Jump on Plus)
 - Go to the address specified if the **Sign flag is not set**
 - JM Address (Jump on Minus)
 - Go to the address specified if the **Sign flag is set.**

Machine Control

– HLT

- Stop executing the program.

– NOP

- No operation
- Exactly as it says, do nothing.
- Usually used for delay or to replace instructions during debugging.

Operand Types

- There are different ways for specifying the operand:
 - There may not be an operand (**implied operand**)
 - CMA
 - The operand may be an 8-bit number (**immediate data**)
 - ADI 4FH
 - The operand may be an internal register (**register**)
 - SUB B
 - The operand may be a 16-bit address (**memory address**)
 - LDA 4000H

Instruction Size

- Depending on the operand type, the instruction may have different sizes. It will occupy a different number of memory bytes.
 - Typically, all instructions occupy **one byte** only.
 - The exception is any instruction that contains **immediate data** or a **memory address**.
 - Instructions that include immediate data use **two bytes**.
 - One for the opcode and the other for the 8-bit data.
 - Instructions that include a memory address occupy **three bytes**.
 - One for the opcode, and the other two for the 16-bit address.

Instruction with Immediate Data

- Operation: Load an 8-bit number into the accumulator.

– MVI A, 32

- Operation: MVI A
- Operand: The number 32
- Binary Code:

0011 1110 3E 1st byte.

0011 0010 32 2nd byte.

Instruction with a Memory Address

- Operation: go to address 2085.

– Instruction: JMP 2085

- Opcode: JMP
- Operand: 2085
- Binary code:

1100 0011 C3 1st byte.

1000 0101 85 2nd byte

0010 0000 20 3rd byte

Addressing Modes

- The microprocessor has different ways of specifying the data for the instruction. These are called “addressing modes”.
- The 8085 has four addressing modes:
 - **Implied** CMA
 - **Immediate** MVI B, 45
 - **Direct** LDA 4000
 - **Indirect** LDAX B
 - Load the accumulator with the contents of the memory location whose address is stored in the register pair BC).

Data Formats

- In an 8-bit microprocessor, data can be represented in one of four formats:
 - ASCII
 - BCD
 - Signed Integer
 - Unsigned Integer.
- It is important to recognize that the microprocessor deals with 0's and 1's.
 - It deals with values as strings of bits.
 - It is the job of the user to add a meaning to these strings.

Data Formats

- Assume the accumulator contains the following value: 0100 0001.
 - There are four ways of reading this value:
 - It is an unsigned integer expressed in binary, the equivalent decimal number would be 65.
 - It is a number expressed in BCD (**B**inary **C**oded **D**ecimal) format. That would make it, 41.
 - It is an **ASCII** representation of a letter. That would make it the letter A.
 - It is a string of 0's and 1's where the 0th and the 6th bits are set to 1 while all other bits are set to 0.

ASCII stands for **A**merican **S**tandard **C**ode for **I**nformation **I**nterchange.

Counters & Time Delays

Counters

- A loop counter is set up by loading a register with a certain value
- Then using the DCR (to decrement) and INR (to increment) the contents of the register are updated.
- A loop is set up with a conditional jump instruction that loops back or not depending on whether the count has reached the termination count.

Counters

- The operation of a loop counter can be described using the following flowchart.

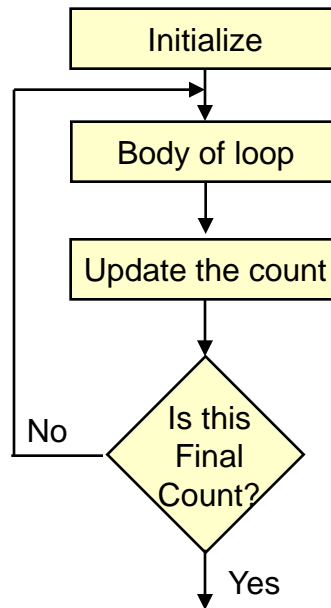

Sample ALP for implementing a loop Using DCR instruction

```
                MVI C, 15H  
LOOP           DCR C  
                JNZ LOOP
```

Using a Register Pair as a Loop Counter

- Using a single register, one can repeat a loop for a maximum count of 255 times.
- It is possible to increase this count by using a register pair for the loop counter instead of the single register.
 - A minor problem arises in how to test for the final count since DCX and INX do not modify the flags.
 - However, if the loop is looking for when the count becomes zero, we can use a small trick by ORing the two registers in the pair and then checking the zero flag.

Using a Register Pair as a Loop Counter

- The following is an example of a loop set up with a register pair as the loop counter.

```
        LXI B, 1000H  
LOOP   DCX B  
        MOV A, C  
        ORA B  
        JNZ LOOP
```

Delays

- It was shown in Chapter 2 that each instruction passes through different combinations of Fetch, Memory Read, and Memory Write cycles.
- Knowing the combinations of cycles, one can calculate how long such an instruction would require to complete.
- The table in Appendix F of the book contains a column with the title B/M/T.
 - B for Number of Bytes
 - M for Number of Machine Cycles
 - T for Number of T-State.

Delays

- Knowing how many T-States an instruction requires, and keeping in mind that a T-State is one clock cycle long, we can calculate the time using the following formula:

$$\text{Delay} = \text{No. of T-States} / \text{Frequency}$$

- For example a “MVI” instruction uses 7 T-States. Therefore, if the Microprocessor is running at 2 MHz, the instruction would require 3.5 μ Seconds to complete.

Delay loops

- We can use a loop to produce a certain amount of time delay in a program.
- The following is an example of a delay loop:

MVI C, FFH	7 T-States
LOOP DCR C	4 T-States
JNZ LOOP	10 T-States

- The first instruction initializes the loop counter and is executed only once requiring only 7 T-States.
- The following two instructions form a loop that requires 14 T-States to execute and is repeated 255 times until C becomes 0.

Delay Loops (Contd.)

- We need to keep in mind though that in the last iteration of the loop, the JNZ instruction will fail and require only 7 T-States rather than the 10.
- Therefore, we must deduct 3 T-States from the total delay to get an accurate delay calculation.
- To calculate the delay, we use the following formula:

$$T_{\text{delay}} = T_{\text{O}} + T_{\text{L}}$$

- T_{delay} = total delay
 - T_{O} = delay outside the loop
 - T_{L} = delay of the loop
- T_{O} is the sum of all delays outside the loop.

Delay Loops (Contd.)

- Using these formulas, we can calculate the time delay for the previous example:
- $T_O = 7$ T-States
 - Delay of the MVI instruction
- $T_L = (14 \times 255) - 3 = 3567$ T-States
 - 14 T-States for the 2 instructions repeated 255 times ($FF_{16} = 255_{10}$) reduced by the 3 T-States for the final JNZ.

Using a Register Pair as a Loop Counter

- Using a single register, one can repeat a loop for a maximum count of 255 times.
- It is possible to increase this count by using a register pair for the loop counter instead of the single register.
 - A minor problem arises in how to test for the final count since DCX and INX do not modify the flags.
 - However, if the loop is looking for when the count becomes zero, we can use a small trick by ORing the two registers in the pair and then checking the zero flag.

Using a Register Pair as a Loop Counter

- The following is an example of a delay loop set up with a register pair as the loop counter.

	LXI B, 1000H	10 T-States
LOOP	DCX B	6 T-States
	MOV A, C	4 T-States
	ORA B	4 T-States
	JNZ LOOP	10 T-States

Using a Register Pair as a Loop Counter

- Using the same formula from before, we can calculate:
- $T_O = 10$ T-States
 - The delay for the LXI instruction
- $T_L = (24 \times 4096) - 3 = 98301$ T- States
 - 24 T-States for the 4 instructions in the loop repeated 4096 times ($1000_{16} = 4096_{10}$) reduced by the 3 T-States for the JNZ in the last iteration.

Nested Loops

- Nested loops can be easily setup in Assembly language by using two registers for the two loop counters and updating the right register in the right loop.
 - In the figure, the body of loop2 can be before or after loop1.

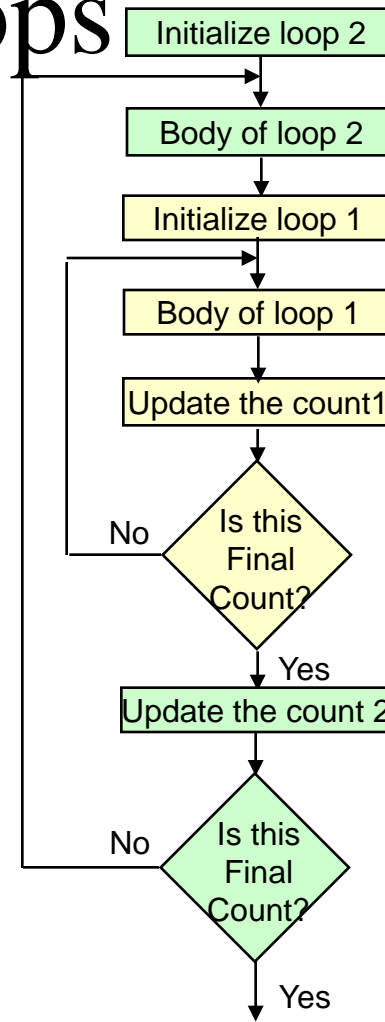

Nested Loops for Delay

- Instead (or in conjunction with) Register Pairs, a nested loop structure can be used to increase the total delay produced.

	MVI B, 10H	7 T-States
LOOP2	MVI C, FFH	7 T-States
LOOP1	DCR C	4 T-States
	JNZ LOOP1	10 T-States
	DCR B	4 T-States
	JNZ LOOP2	10 T-States

Delay Calculation of Nested Loops

- The calculation remains the same except that the formula must be applied recursively to each loop.
 - Start with the inner loop, then plug that delay in the calculation of the outer loop.
- Delay of inner loop
 - $T_{O1} = 7$ T-States
 - MVI C, FFH instruction
 - $T_{L1} = (255 \times 14) - 3 = 3567$ T-States
 - 14 T-States for the DCR C and JNZ instructions repeated 255 times ($FF_{10} = 255_{10}$) minus 3 for the final JNZ.

Delay Calculation of Nested Loops

- Delay of outer loop
 - $T_{O2} = 7$ T-States
 - MVI B, 10H instruction
 - $T_{L1} = (16 \times (14 + 3574)) - 3 = 57405$ T-States
 - 14 T-States for the DCR B and JNZ instructions and 3574 T-States for loop1 repeated 16 times ($10_{16} = 16_{10}$) minus 3 for the final JNZ.
 - $T_{\text{Delay}} = 7 + 57405 = 57412$ T-States
- Total Delay
 - $T_{\text{Delay}} = 57412 \times 0.5 \mu\text{Sec} = 28.706 \text{ mSec}$

Increasing the delay

- The delay can be further increased by using register pairs for each of the loop counters in the nested loops setup.
- It can also be increased by adding dummy instructions (like NOP) in the body of the loop.

Timing Diagram

Representation of Various Control signals generated during Execution of an Instruction.

Following Buses and Control Signals must be shown in a Timing Diagram:

- Higher Order Address Bus.
- Lower Address/Data bus
- ALE
- RD
- WR
- IO/M

Timing Diagram

Instruction:

A000h MOV A,B

Corresponding Coding:

A000h 78

Timing Diagram

Instruction:

A000h MOV A,B

Corresponding Coding:

A000h 78

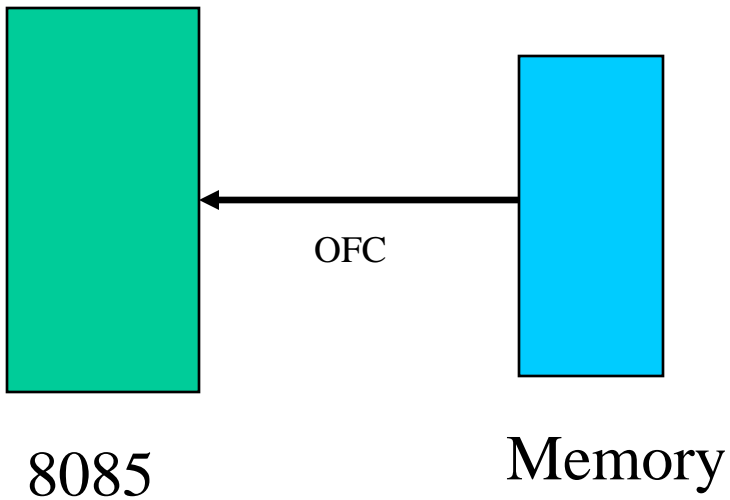

Timing Diagram

Instruction:

A000h MOV A,B

Corresponding Coding:

A000h 78

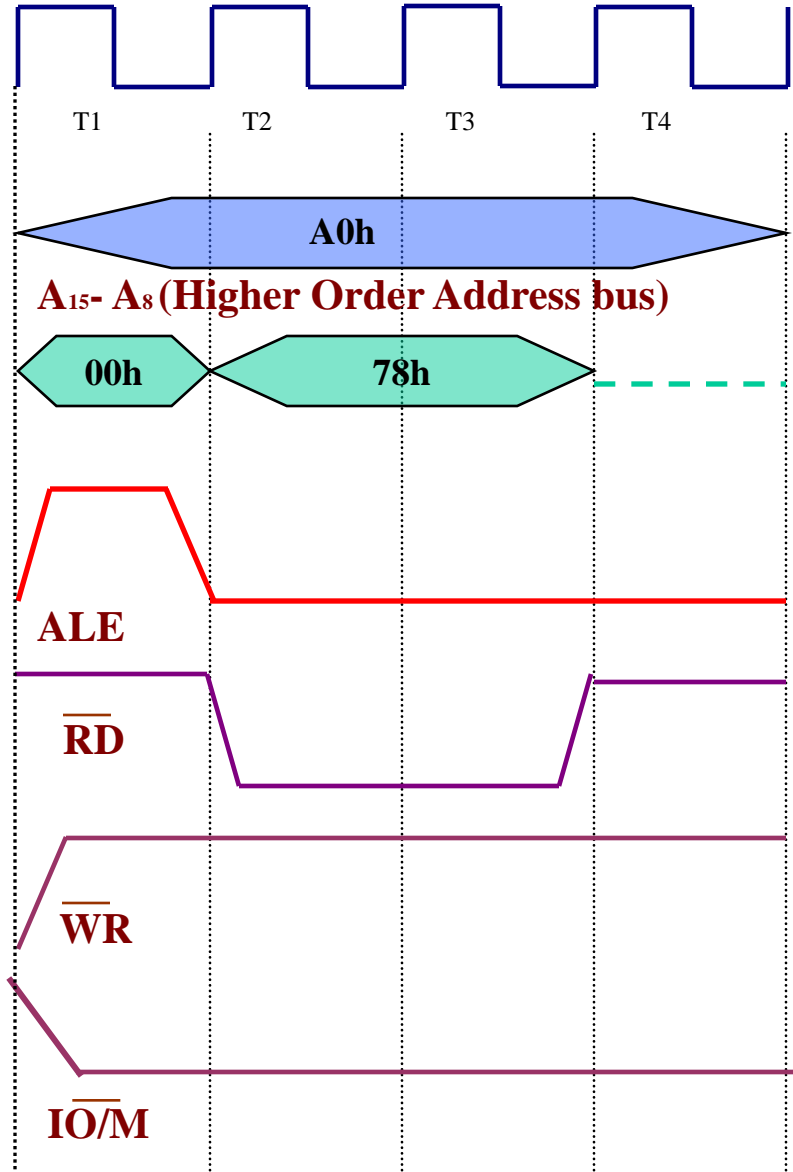
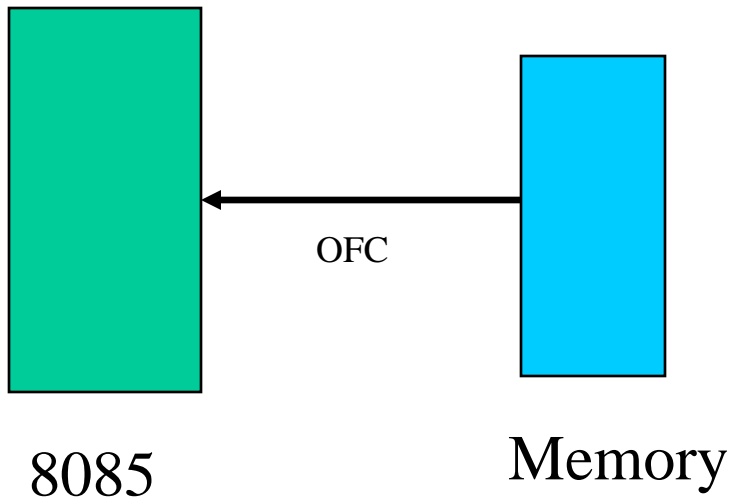

Op-code fetch Cycle

Timing Diagram

Instruction:

A000h MVI A,45h

Corresponding Coding:

A000h 3E

A001h 45

Timing Diagram

Instruction:

A000h MVI A,45h

Corresponding Coding:

A000h 3E

A001h 45

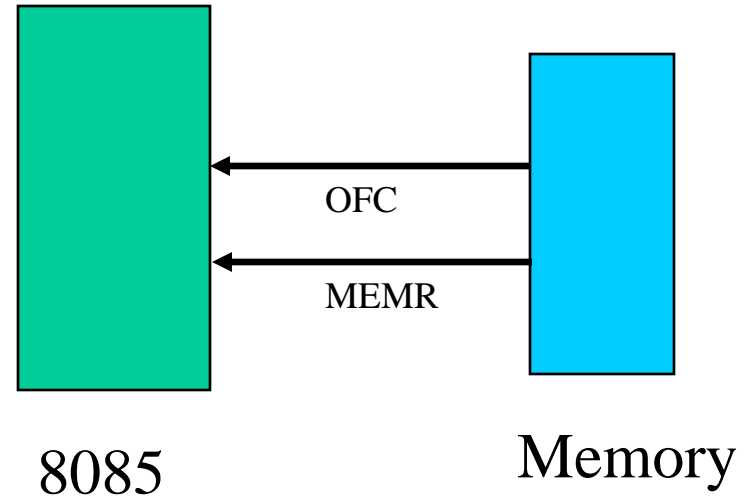

Timing Diagram

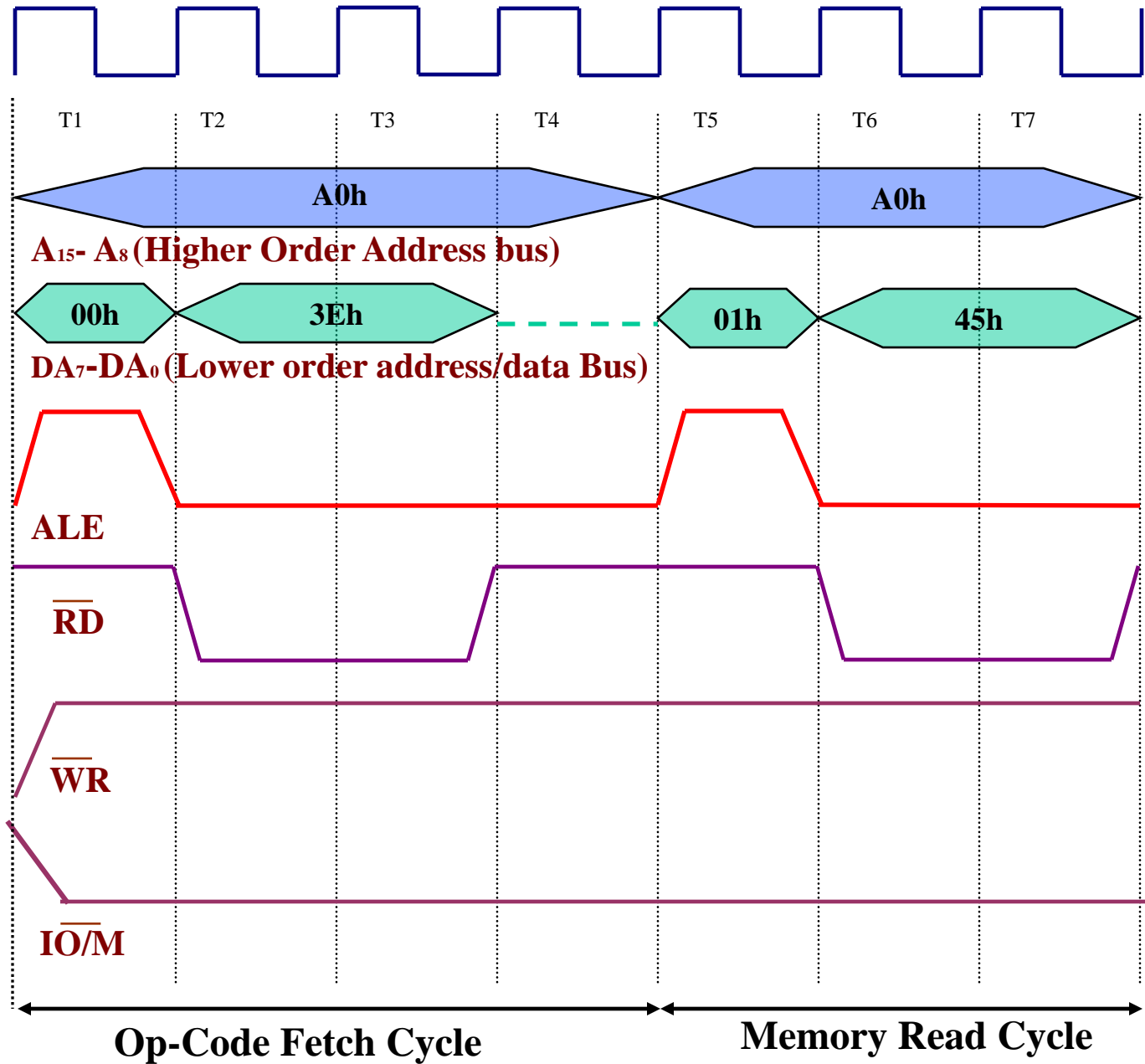

Timing Diagram

Instruction:

A000h LXI A,FO45h

Corresponding Coding:

A000h 21

A001h 45

A002h F0

Timing Diagram

Instruction:

A000h LXI A,FO45h

Corresponding Coding:

A000h 21

A001h 45

A002h F0

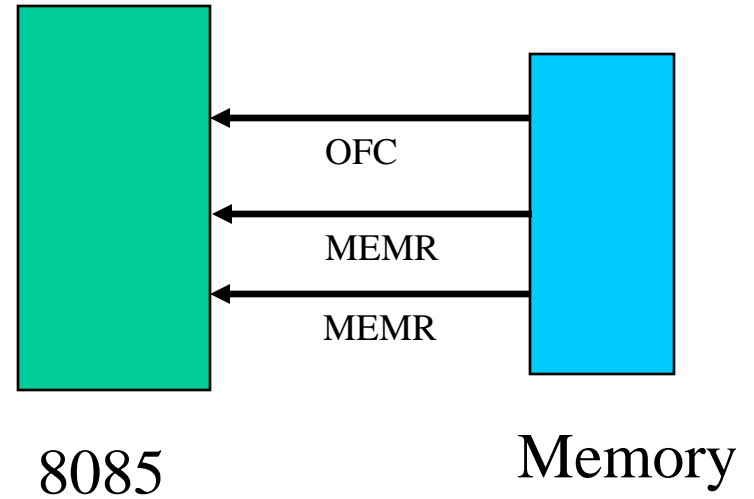

Timing Diagram

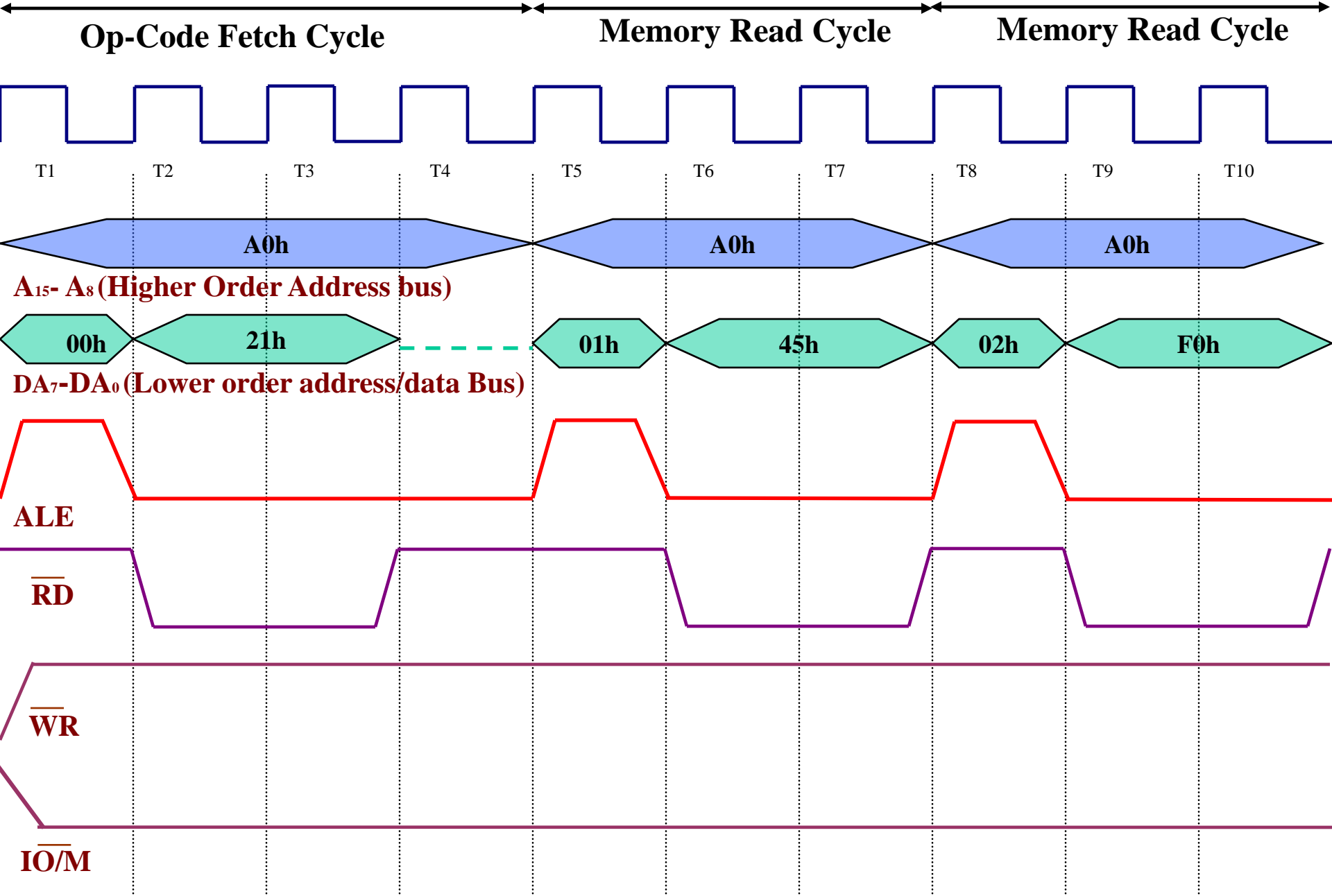

Timing Diagram

Instruction:

A000h MOV A,M

Corresponding Coding:

A000h 7E

Timing Diagram

Instruction:

A000h MOV A,M

Corresponding Coding:

A000h 7E

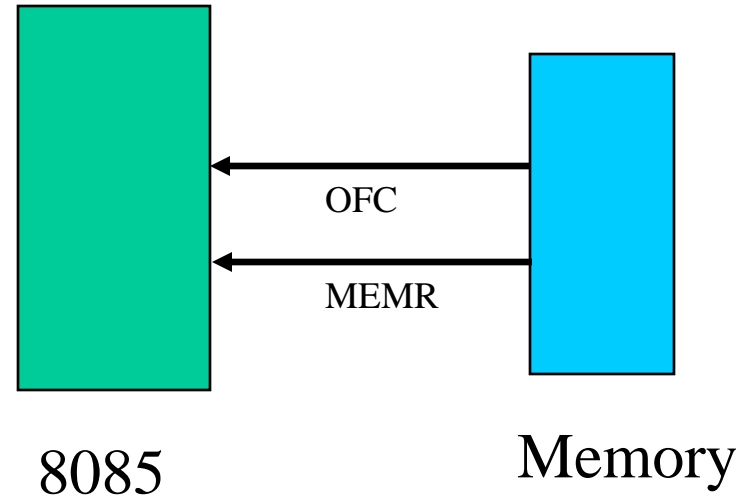

Timing Diagram

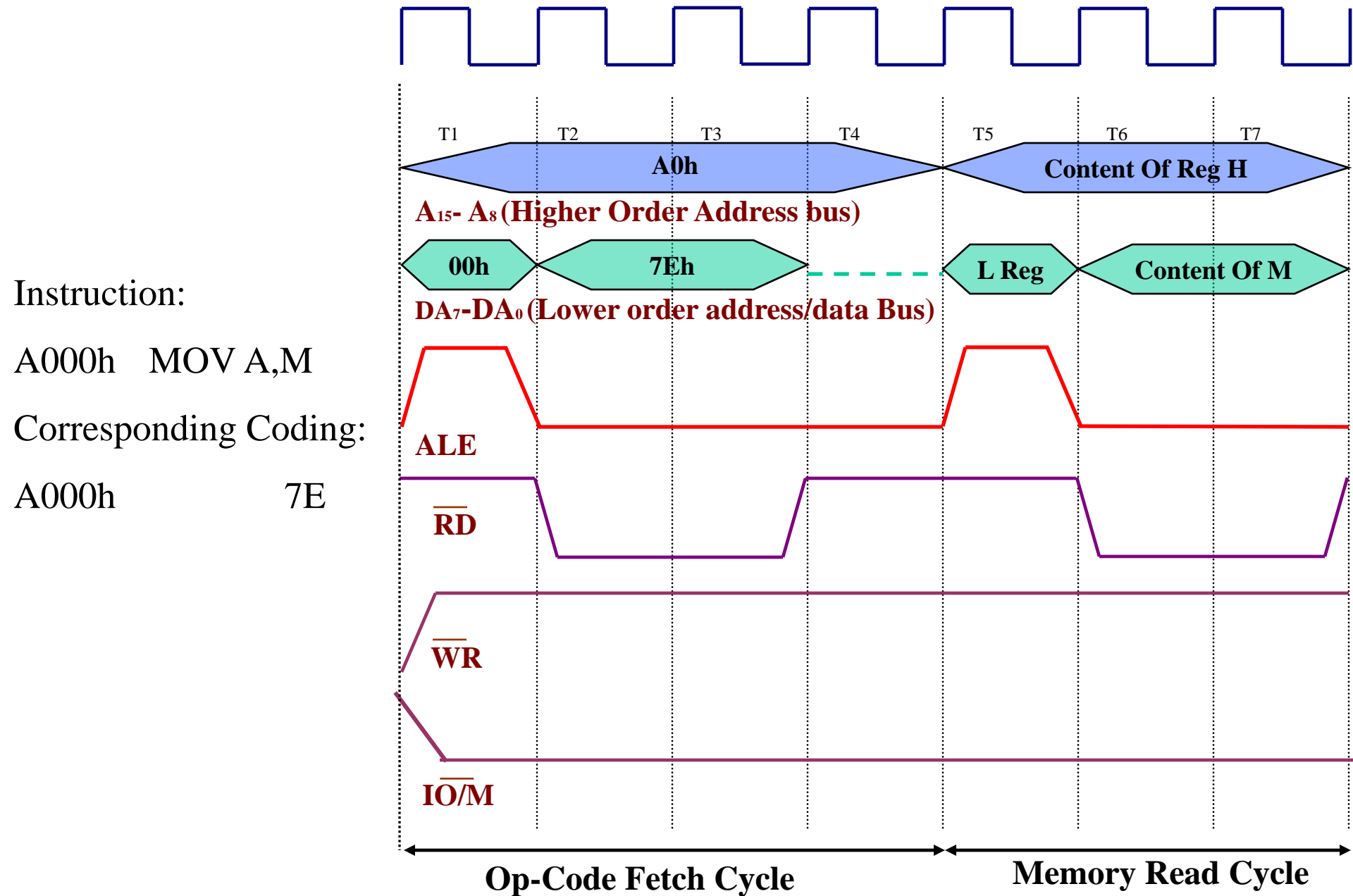

Timing Diagram

Instruction:

A000h MOV M,A

Corresponding Coding:

A000h 77

Timing Diagram

Instruction:

A000h MOV M,A

Corresponding Coding:

A000h 77

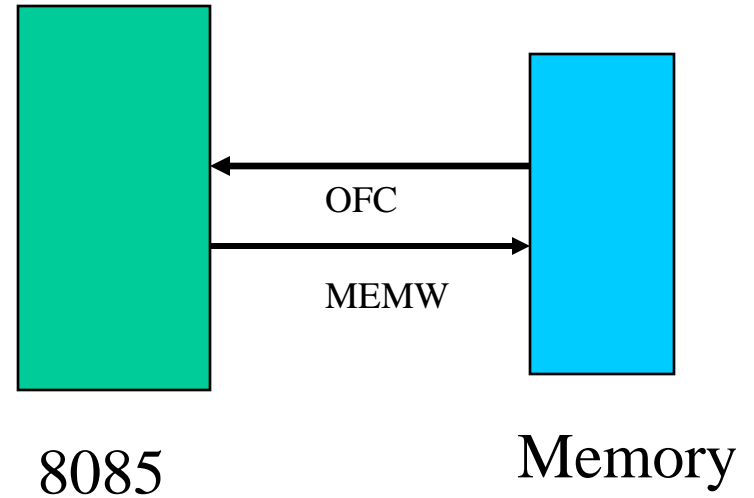

Timing Diagram

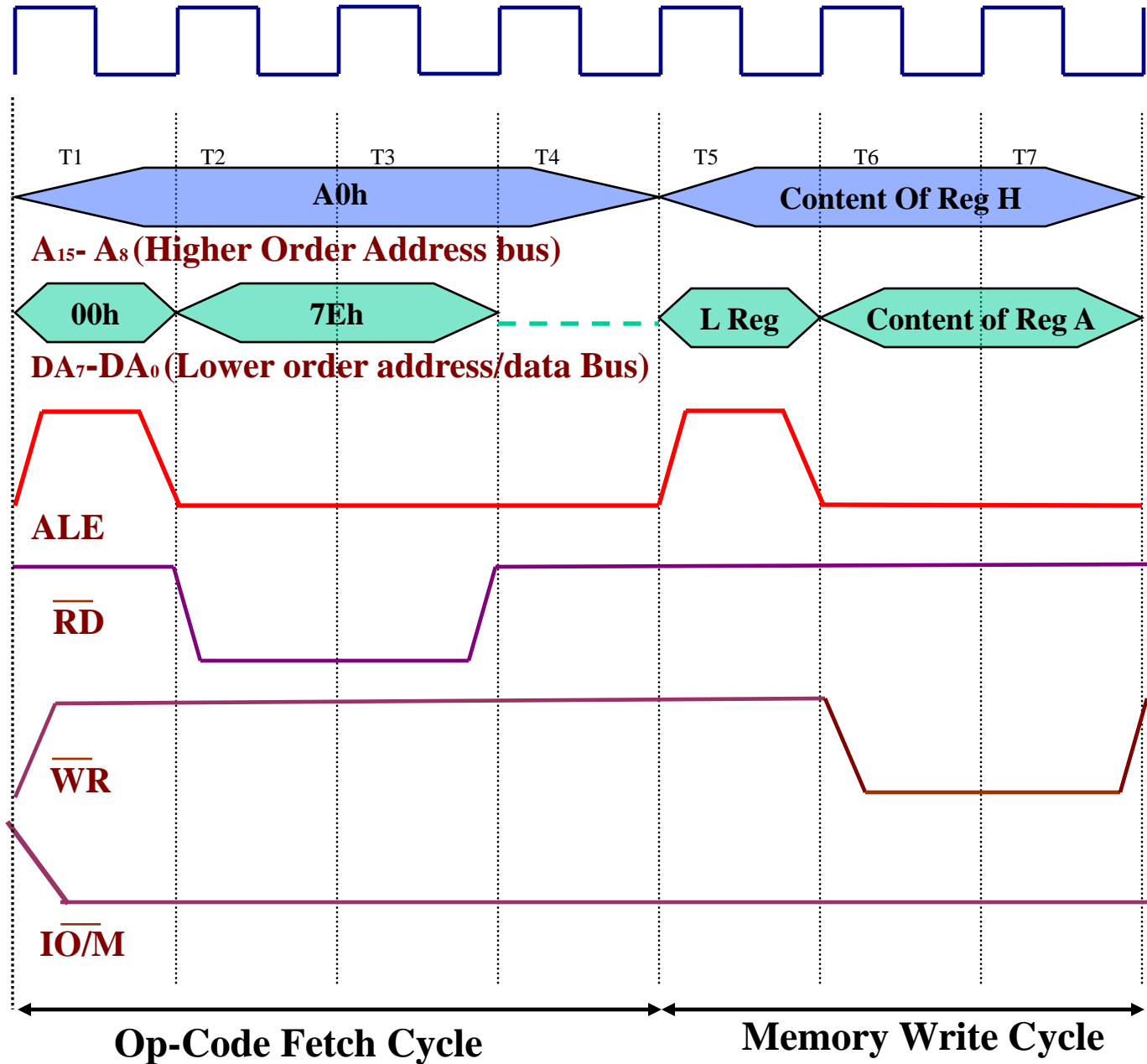

Instruction:

A000h MOV M,A

Corresponding Coding:

A000h 77

Chapter 9

Stack and Subroutines

The Stack

- The stack is an area of memory identified by the programmer for temporary storage of information.
- The stack is a LIFO structure.
 - Last In First Out.
- The stack normally grows backwards into memory.
 - In other words, the programmer defines the bottom of the stack and the stack grows up into reducing address range.

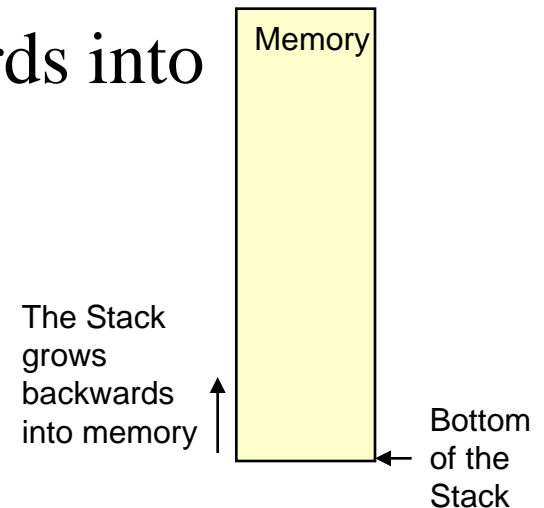

The Stack

- Given that the stack grows backwards into memory, it is customary to place the bottom of the stack at the end of memory to keep it as far away from user programs as possible.
- In the 8085, the stack is defined by setting the SP (Stack Pointer) register.

```
LXI SP, FFFFH
```

- This sets the Stack Pointer to location FFFFH (end of memory for the 8085).

Saving Information on the Stack

- Information is saved on the stack by PUSHing it on.
 - It is retrieved from the stack by POPing it off.
- The 8085 provides two instructions: PUSH and POP for storing information on the stack and retrieving it back.
 - Both PUSH and POP work with register pairs ONLY.

The PUSH Instruction

- PUSH B

- Decrement SP

- Copy the contents of register B to the memory location pointed to by SP

- Decrement SP

- Copy the contents of register C to the memory location pointed to by SP

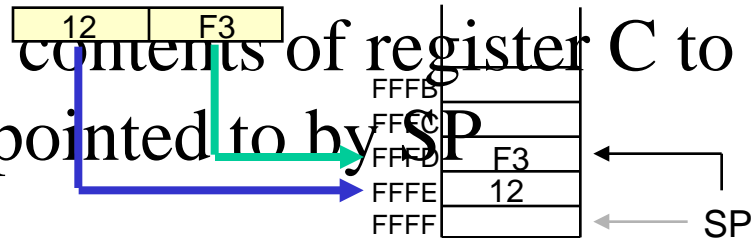

The POP Instruction

- POP D
 - Copy the contents of the memory location pointed to by the SP to register E
 - Increment SP
 - Copy the contents of the memory location pointed to by the SP to register D
 - Increment SP

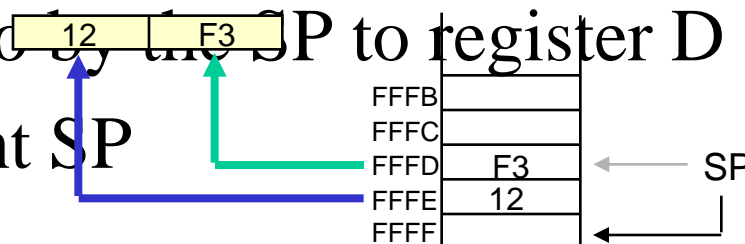

Operation of the Stack

- During pushing, the stack operates in a “decrement then store” style.
 - The stack pointer is decremented first, then the information is placed on the stack.
- During popping, the stack operates in a “use then increment” style.
 - The information is retrieved from the top of the the stack and then the pointer is incremented.
- The SP pointer always points to “the top of the stack”.

LIFO

- The order of PUSHs and POPs must be opposite of each other in order to retrieve information back into its original location.

PUSH B

PUSH D

...

POP D

POP B

The PSW Register Pair

- The 8085 recognizes one additional register pair called the PSW (Program Status Word).
 - This register pair is made up of the Accumulator and the Flags registers.
- It is possible to push the PSW onto the stack, do whatever operations are needed, then POP it off of the stack.
 - The result is that the contents of the Accumulator and the status of the Flags are returned to what they were before the operations were executed.

Subroutines

- A subroutine is a group of instructions that will be used repeatedly in different locations of the program.
 - Rather than repeat the same instructions several times, they can be grouped into a subroutine that is called from the different locations.
- In Assembly language, a subroutine can exist anywhere in the code.
 - However, it is customary to place subroutines separately from the main program.

Subroutines

- The 8085 has two instructions for dealing with subroutines.
 - The CALL instruction is used to redirect program execution to the subroutine.
 - The RTE instruction is used to return the execution to the calling routine.

The CALL Instruction

- CALL 4000H

- Push the address of the instruction immediately following the CALL onto the stack

2000
2003

- Load the program counter with the 16-bit address supplied with the CALL instruction.

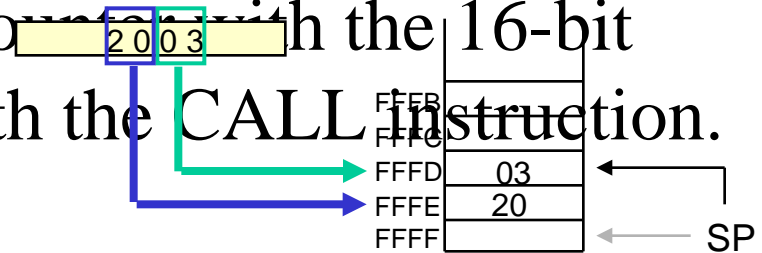

The RTE Instruction

- RTE
 - Retrieve the return address from the top of the stack
 - Load the program counter with the return address.

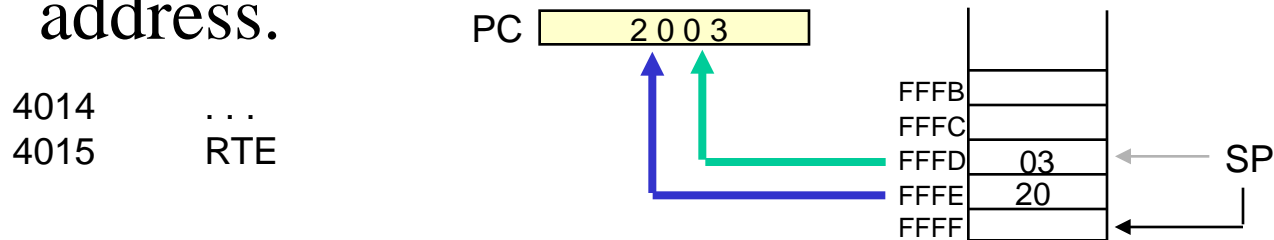

Cautions

- The CALL instruction places the return address at the two memory locations immediately before where the Stack Pointer is pointing.
 - You must set the SP correctly BEFORE using the CALL instruction.
- The RTE instruction takes the contents of the two memory locations at the top of the stack and uses these as the return address.
 - Do not modify the stack pointer in a subroutine. You will lose the return address.

Passing Data to a Subroutine

- In Assembly Language data is passed to a subroutine through registers.
 - The data is stored in one of the registers by the calling program and the subroutine uses the value from the register.
- The other possibility is to use agreed upon memory locations.
 - The calling program stores the data in the memory location and the subroutine retrieves the data from the location and uses it.

Call by Reference and Call by Value

- If the subroutine performs operations on the contents of the registers, then these modifications will be transferred back to the calling program upon returning from a subroutine.
 - Call by reference
- If this is not desired, the subroutine should PUSH all the registers it needs on the stack on entry and POP them on return.
 - The original values are restored before execution returns to the calling program.

Cautions with PUSH and POP

- PUSH and POP should be used in opposite order.
- There has to be as many POP's as there are PUSH's.
 - If not, the RET statement will pick up the wrong information from the top of the stack and the program will fail.
- It is not advisable to place PUSH or POP inside a loop.

Conditional CALL and RTE Instructions

- The 8085 supports conditional CALL and conditional RTE instructions.
 - The same conditions used with conditional JUMP instructions can be used.
 - CC, call subroutine if Carry flag is set.
 - CNC, call subroutine if Carry flag is not set
 - RC, return from subroutine if Carry flag is set
 - RNC, return from subroutine if Carry flag is not set
 - Etc.

A Proper Subroutine

- According to Software Engineering practices, a proper subroutine:
 - Is only entered with a CALL and exited with an RTE
 - Has a single entry point
 - Do not use a CALL statement to jump into different points of the same subroutine.
 - Has a single exit point
 - There should be one return statement from any subroutine.
- Following these rules, there should not be any confusion with PUSH and POP usage.

The Design and Operation of Memory

- Memory in a microprocessor system is where information (data and instructions) is kept. It can be classified into two main types:
 - Main memory (RAM and ROM)
 - Storage memory (Disks , CD ROMs, etc.)
- The simple view of RAM is that it is made up of registers that are made up of flip-flops (or memory elements).
 - The number of flip-flops in a “memory register” determines the size of the memory word.
- ROM on the other hand uses diodes instead of the flip-flops to permanently hold the information.

Accessing Information in Memory

- For the microprocessor to access (Read or Write) information in memory (RAM or ROM), it needs to do the following:
 - Select the right memory chip (using part of the address bus).
 - Identify the memory location (using the rest of the address bus).
 - Access the data (using the data bus).

Tri-State Buffers

- An important circuit element that is used extensively in memory.
- This buffer is a logic circuit that has three states:
 - Logic 0, logic 1, and high impedance.
 - When this circuit is in high impedance mode it looks as if it is disconnected from the output completely.

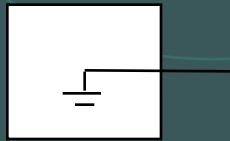

The Output is Low

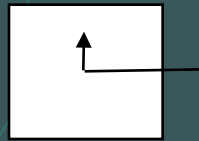

The Output is High



High Impedance

The Tri-State Buffer

- This circuit has two inputs and one output.
 - The first input behaves like the normal input for the circuit.
 - The second input is an "enable".
 - If it is set high, the output follows the proper circuit behavior.
 - If it is set low, the output looks like a wire connected to nothing.

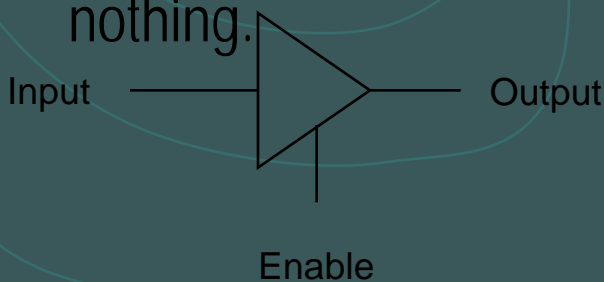

OR

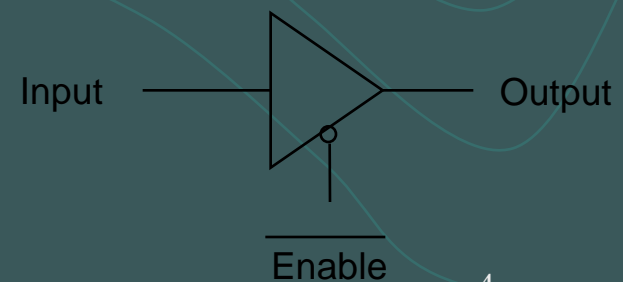

The Basic Memory Element

- The basic memory element is similar to a D latch.
- This latch has an input where the data comes in. It has an enable input and an output on which data comes out.

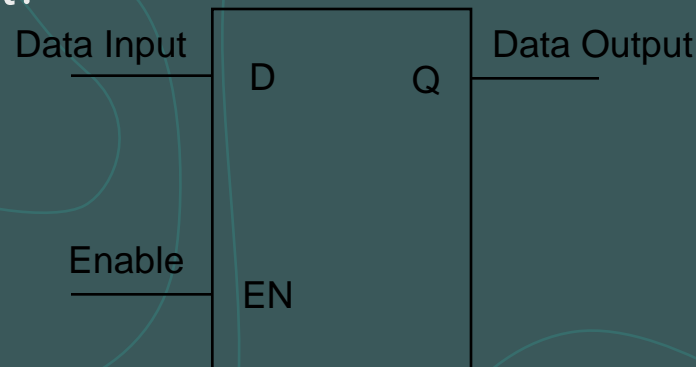

The Basic Memory Element

- However, this is not safe.
 - Data is always present on the input and the output is always set to the contents of the latch.
 - To avoid this, tri-state buffers are added at the input and output of the latch.

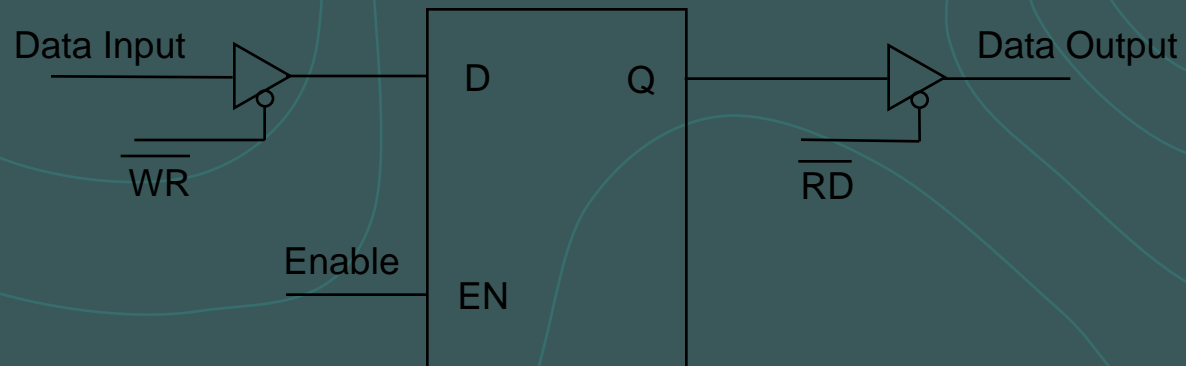

The Basic Memory Element

- The \overline{WR} signal controls the input buffer.
 - The bar over WR means that this is an active low signal.
 - So, if WR is 0 the input data reaches the latch input.
 - If WR is 1 the input of the latch looks like a wire connected to nothing.
- The \overline{RD} signal controls the output in a similar manner.

A Memory "Register"

- If we take four of these latches and connect them together, we would have a 4-bit memory register

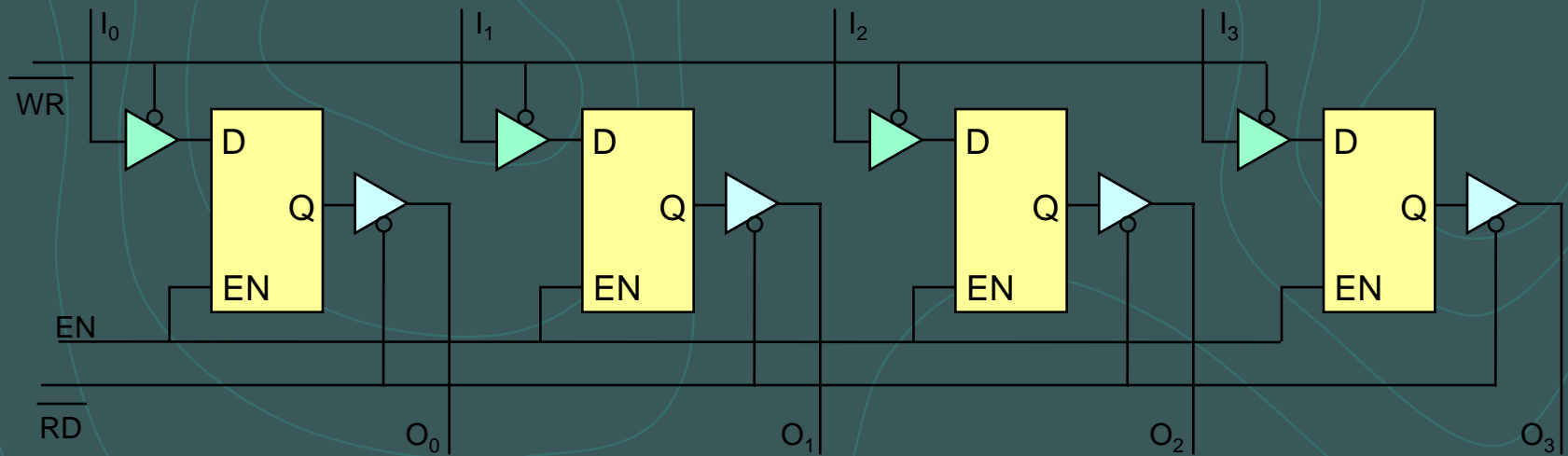

A group of memory registers

- Expanding on this scheme to add more memory registers we get the diagram to the right.

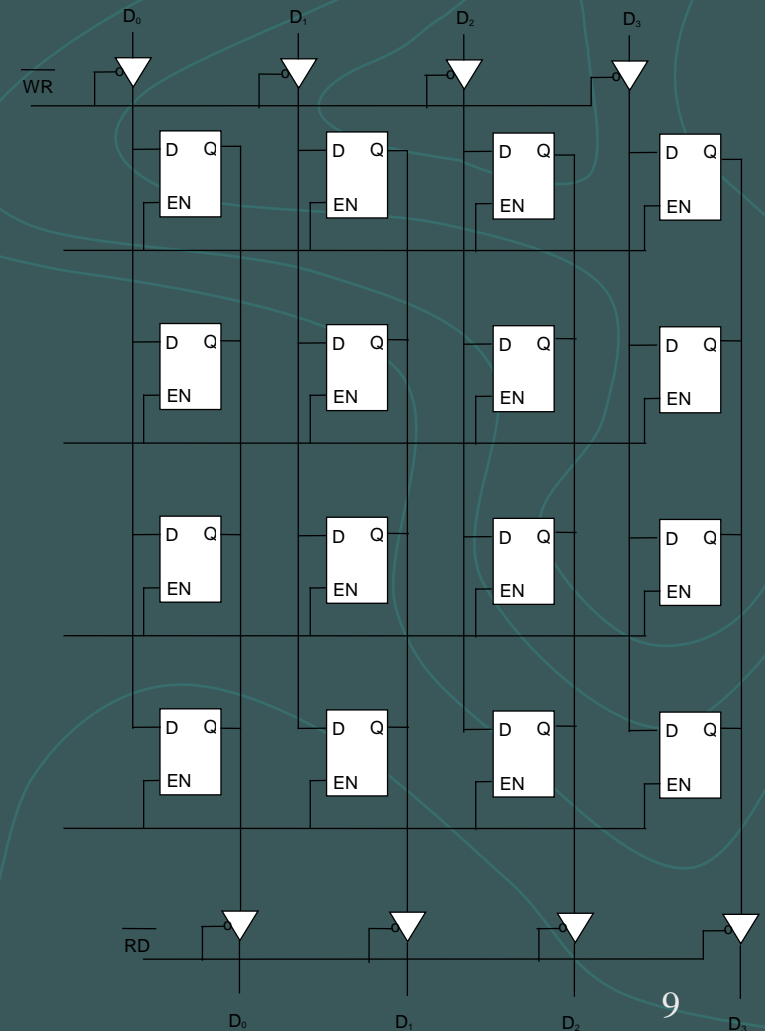

Externally Initiated Operations

- External devices can initiate (start) one of the 4 following operations:
 - **Reset**
 - All operations are stopped and the program counter is reset to 0000.
 - **Interrupt**
 - The microprocessor's operations are interrupted and the microprocessor executes what is called a "**service routine**".
 - This routine "handles" the interrupt, (perform the necessary operations). Then the microprocessor returns to its previous operations and continues.

A group of Memory Registers

- If we represent each memory location (Register) as a block we get the following

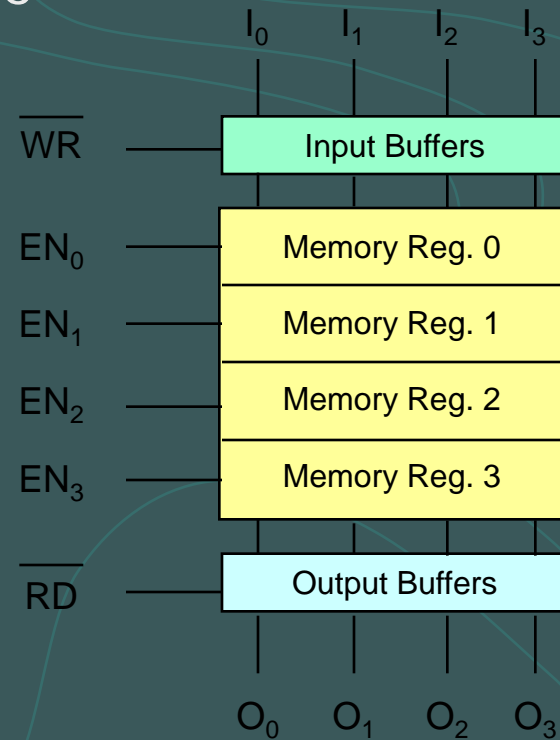

The Design of a Memory Chip

- Using the RD and WR controls we can determine the direction of flow either into or out of memory. Then using the appropriate Enable input we enable an individual memory register.
- What we have just designed is a memory with 4 locations and each location has 4 elements (bits). This memory would be called 4 X 4 [Number of location X number of bits per location].

A vertical strip on the left side of the slide shows a microchip die with various colored traces and structures. The main background of the slide is dark teal with light teal wavy lines.

The Enable Inputs

- How do we produce these enable line?
 - Since we can never have more than one of these enables active at the same time, we can have them encoded to reduce the number of lines coming into the chip.
 - These encoded lines are the address lines for memory.

The Design of a Memory Chip

- So, the previous diagram would now look like the following:

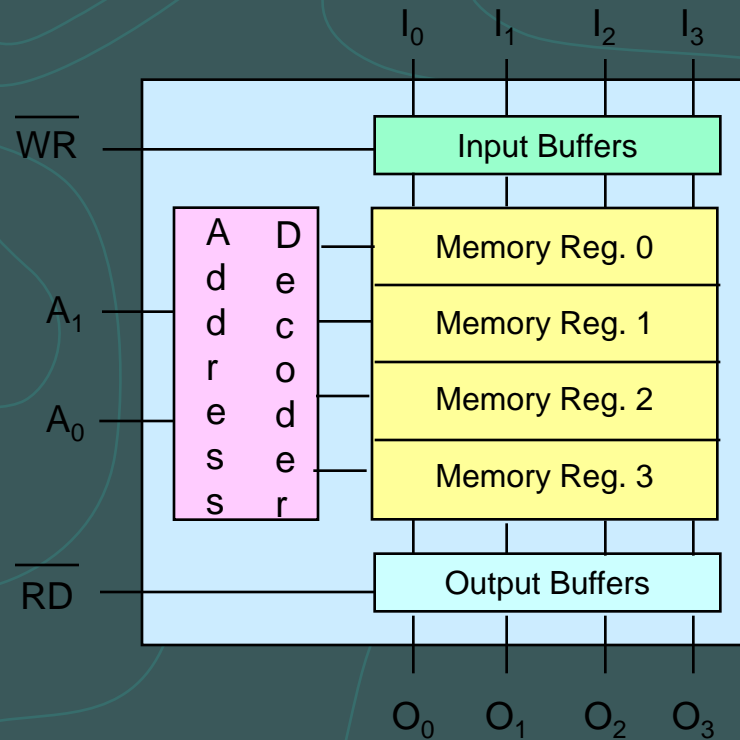

The Design of a Memory Chip

- Since we have tri-state buffers on both the inputs and outputs of the flip flops, we can actually use

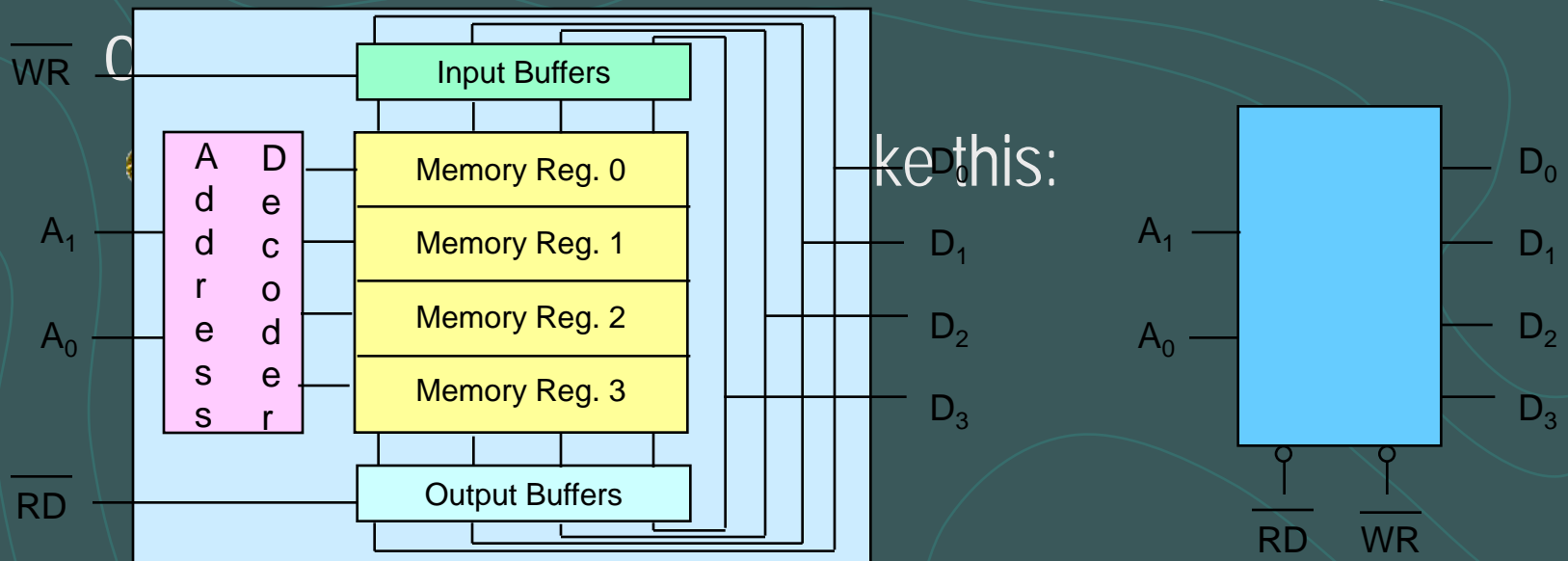

The steps of writing into Memory

- What happens when the programmer issues the STA instruction?
 - The microprocessor would turn **on** the WR control ($WR = 0$) and turn **off** the RD control ($RD = 1$).
 - The address is applied to the address decoder which generates a **single** Enable signal to turn on **only one** of the memory registers.
 - The data is then applied on the data lines and it is stored into the enabled register.

Dimensions of Memory

- Memory is usually measured by two numbers: its length and its width (Length X Width).
 - The length is the total number of locations.
 - The width is the number of bits in each location.
- The length (total number of locations) is a function of the number of address lines.

$$\# \text{ of memory locations} = 2^{(\# \text{ of address lines})}$$

- So, a memory chip with 10 address lines would have
 $2^{10} = 1024$ locations (1K)
- Looking at it from the other side, a memory chip with 4K locations would need

$$\text{Log}_2 4096 = 12 \text{ address lines}$$

The 8085 and Memory

- The 8085 has 16 address lines. That means it can address

$2^{16} = 64\text{K}$ memory locations.

- Then it will need 1 memory chip with 64 k locations, or 2 chips with 32 K in each, or 4 with 16 K each or 16 of the 4 K chips, etc.
- how would we use these address lines to control the multiple chips?



Chip Select

- Usually, each memory chip has a CS (Chip Select) input. The chip will only work if an active signal is applied on that input.
- To allow the use of multiple chips in the make up of memory, we need to use a number of the address lines for the purpose of “chip selection”.
 - These address lines are decoded to generate the 2^n necessary CS inputs for the memory chips to be used.



Chip Selection Example

- Assume that we need to build a memory system made up of 4 of the 4 X 4 memory chips we designed earlier.
- We will need to use 2 inputs and a decoder to identify which chip will be used at what time.
- The resulting design would now look like the one on the following slide.

Chip Selection Example

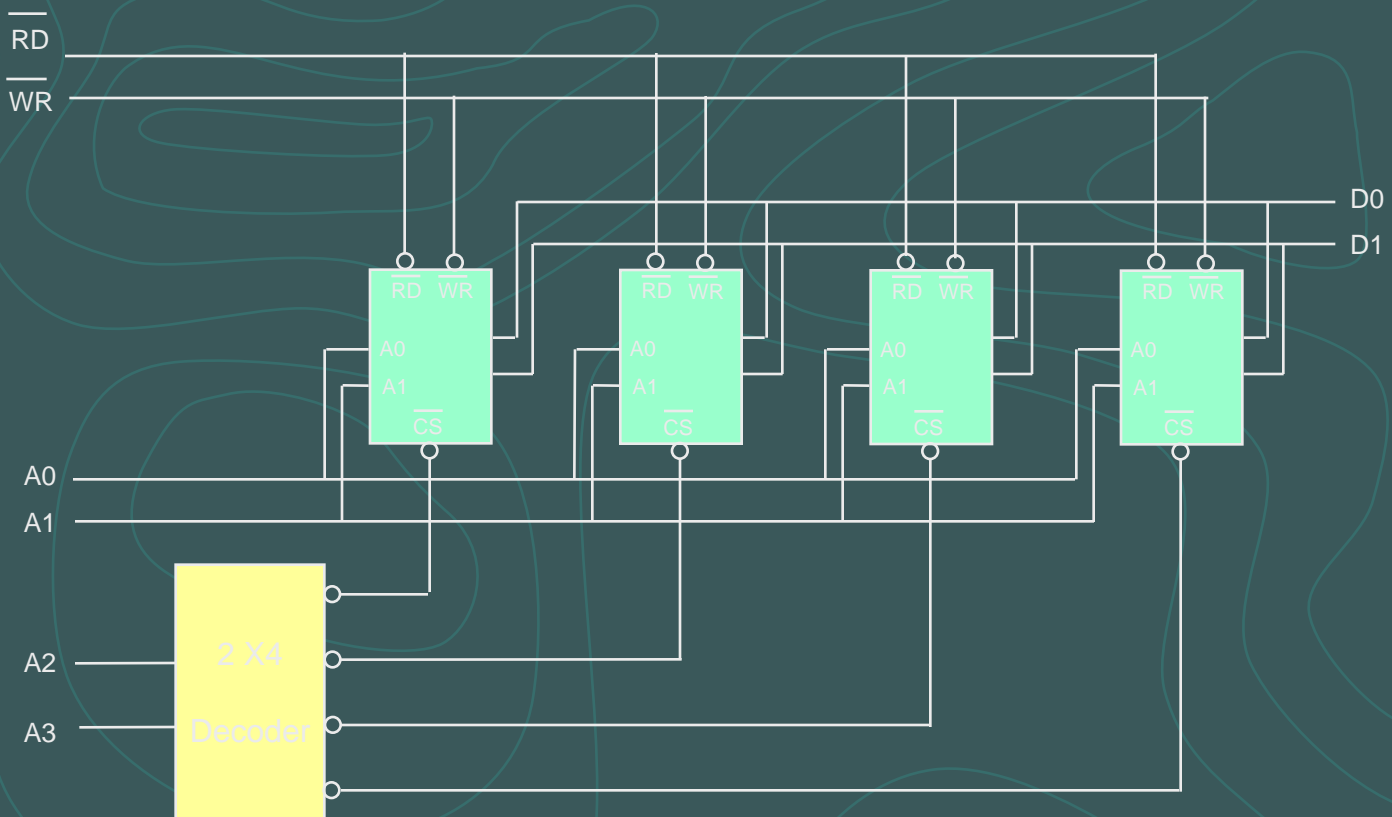

Memory Map and Addresses

- The memory map is a picture representation of the address range and shows where the different memory chips are located within the address range.

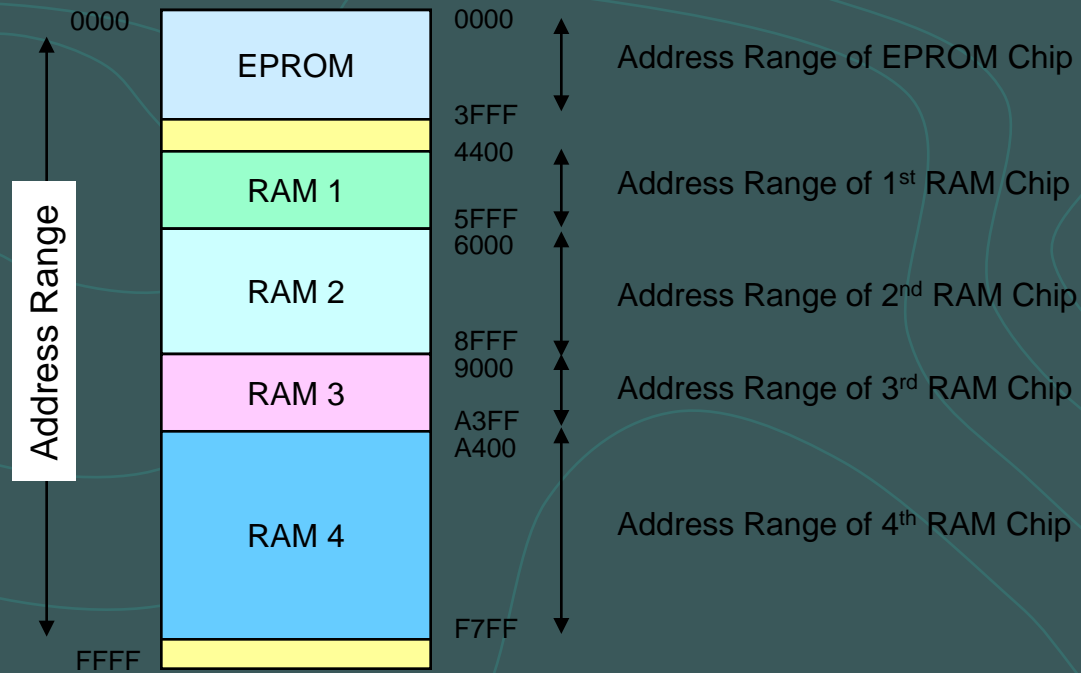

Address Range of a Memory Chip

- The address range of a particular chip is the list of all addresses that are mapped to the chip.
- An example for the address range and its relationship to the memory chips would be the Post Office Boxes in the post office.
 - Each box has its unique number that is assigned sequentially. (memory locations)
 - The boxes are grouped into groups. (memory chips)
 - The first box in a group has the number immediately after the last box in the previous group.

Address Range of a Memory Chip

- The above example can be modified slightly to make it closer to our discussion on memory.
 - Let's say that this post office has only 1000 boxes.
 - Let's also say that these are grouped into 10 groups of 100 boxes each. Boxes 0000 to 0099 are in group 0, boxes 0100 to 0199 are in group 1 and so on.
- We can look at the box number as if it is made up of two pieces:
 - The group number and the box's index within the group.
 - So, box number 436 is the 36th box in the 4th group.

The upper digit of the box number identifies the group and the lower two digits identify the box within the group.

The 8085 and Address Ranges

- The 8085 has 16 address lines. So, it can address a total of 64K memory locations.
 - If we use memory chips with 1K locations each, then we will need 64 such chips.
 - The 1K memory chip needs 10 address lines to uniquely identify the 1K locations. ($\log_2 1024 = 10$)
 - That leaves 6 address lines which is the exact number needed for selecting between the 64 different chips ($\log_2 64 = 6$).

The 8085 and Address Ranges

- Now, we can break up the 16-bit address of the 8085 into two pieces:



- Depending on the combination on the address lines $A_{15} - A_{10}$, the address range of the specified chip is determined.

Chip Select Example

- A chip that uses the combination $A_{15} - A_{10} = 001000$ would have addresses that range from 2000H to 23FFH.
- Keep in mind that the 10 address lines on the chip gives a range of 00 0000 0000 to 11 1111 1111 or 000H to 3FFH for each of the chips.
- The memory chip in this example would require the following circuit on its chip select input:

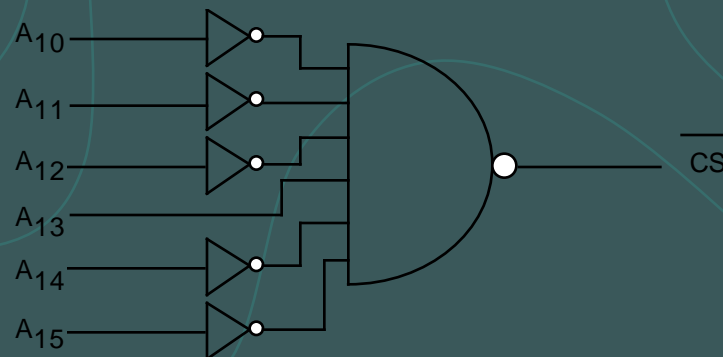

Chip Select Example

- If we change the above combination to the following:

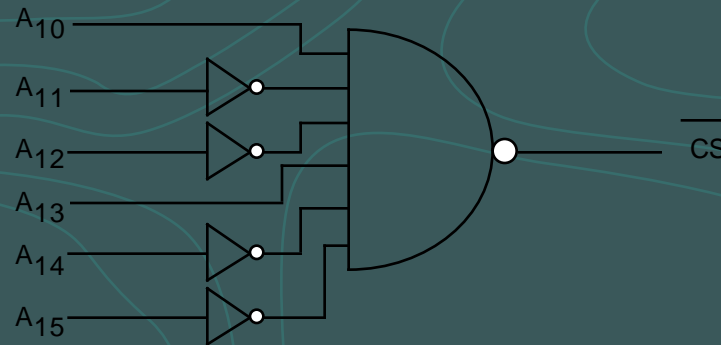

- Now the chip would have addresses ranging from: 2400 to 27FF.
- Changing the combination of the address bits connected to the chip select changes the address range for the memory chip.

Chip Select Example

- To illustrate this with a picture:
 - in the first case, the memory chip occupies the piece of the memory map identified as before.
 - In the second case, it occupies the piece identified as after.

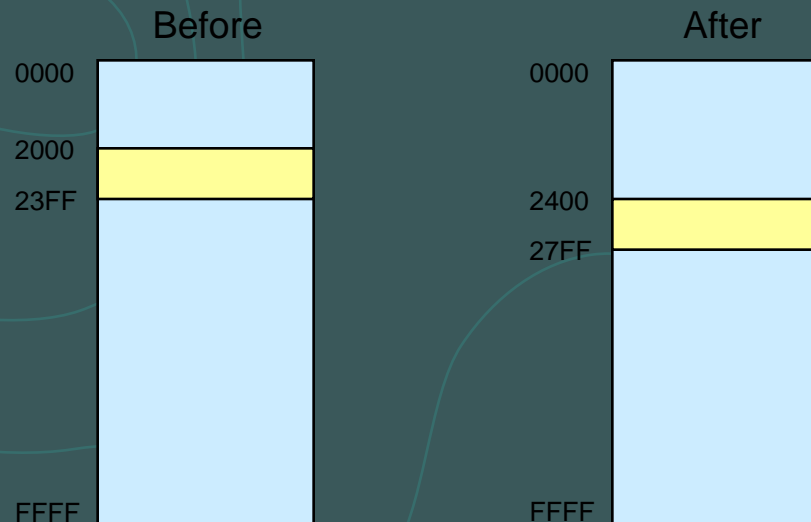

High-Order vs. Low-Order Address Lines

- The address lines from a microprocessor can be classified into two types:
 - High-Order
 - Used for memory chip selection
 - Low-Order
 - Used for location selection within a memory chip.
- This classification is highly dependent on the memory system design.



Data Lines

- All of the above discussion has been regarding memory length. Lets look at memory width.
- We said that the width is the number of bits in each memory word.
 - We have been assuming so far that our memory chips have the right width.
 - What if they don't?
 - It is very common to find memory chips that have only 4 bits per location. How would you design a byte wide memory system using these chips?
 - We use two chips for the same address range. One chip will supply 4 of the data bits per address and the other chip supply the other 4 data bits for the same address.

Data Lines

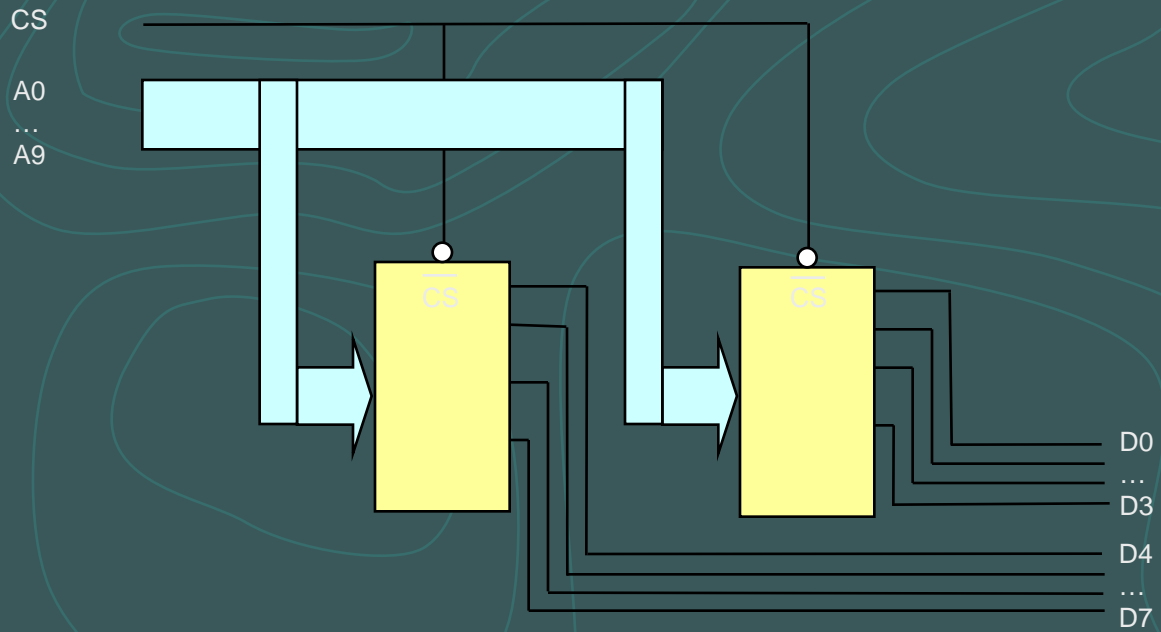

Interrupts

Interrupts

- Interrupt is a process where an external device can get the attention of the microprocessor.
 - The process **starts** from the I/O device
 - The process is **asynchronous**.
- Interrupts can be classified into two types:
 - Maskable (can be delayed)
 - Non-Maskable (can not be delayed)
- Interrupts can also be classified into:
 - Vectored (the address of the service routine is hard-wired)
 - Non-vectored (the address of the service routine needs to be supplied externally)

Interrupts

- An interrupt is considered to be an **emergency signal**.
 - The Microprocessor should respond to it **as soon as possible**.
- When the Microprocessor receives an interrupt signal, it **suspends the currently executing program** and **jumps to an Interrupt Service Routine (ISR)** to respond to the incoming interrupt.
 - Each interrupt will most probably have its own ISR.

Responding to Interrupts

- Responding to an interrupt may be **immediate** or **delayed** depending on whether the interrupt is maskable or non-maskable and whether interrupts are being masked or not.
- There are two ways of redirecting the execution to the ISR depending on whether the interrupt is vectored or non-vectored.
 - The vector is **already known** to the Microprocessor
 - The **device will have to supply** the vector to the Microprocessor

The 8085 Interrupts

- The maskable interrupt process in the 8085 is controlled by a single flip flop inside the microprocessor. This Interrupt Enable flip flop is controlled using the two instructions “EI” and “DI”.
- The 8085 has a single **Non-Maskable** interrupt.
 - The non-maskable interrupt is not affected by the value of the Interrupt Enable flip flop.

The 8085 Interrupts

- The 8085 has 5 interrupt inputs.
 - The INTR input.
 - The INTR input is the only **non-vector** interrupt.
 - INTR is **maskable** using the EI/DI instruction pair.
 - RST 5.5, RST 6.5, RST 7.5 are all **automatically vectored**.
 - RST 5.5, RST 6.5, and RST 7.5 are all **maskable**.
 - TRAP is the only **non-maskable** interrupt in the 8085
 - TRAP is also **automatically vectored**

The 8085 Interrupts

Interrupt name	Maskable	Vectored
INTR	Yes	No
RST 5.5	Yes	Yes
RST 6.5	Yes	Yes
RST 7.5	Yes	Yes
TRAP	No	Yes

Interrupt Vectors and the Vector Table

- An **interrupt vector** is a pointer to where the ISR is stored in memory.
- All interrupts (vectored or otherwise) are mapped onto a memory area called the **Interrupt Vector Table** (IVT).
 - The IVT is usually located in **memory page 00** (0000H - 00FFH).
 - The purpose of the IVT is to hold the vectors that redirect the microprocessor to the right place when an interrupt arrives.
 - The IVT is divided into several blocks. Each block is used by one of the interrupts to hold its “**vector**”

The 8085 Non-Vectored Interrupt Process

1. The interrupt process should be **enabled** using the **EI** instruction.
2. The 8085 checks for an interrupt during the execution of **every** instruction.
3. If there is an interrupt, the microprocessor will **complete the executing instruction**, and start a **RESTART** sequence.
4. The RESTART sequence **resets the interrupt flip flop** and **activates the interrupt acknowledge signal (INTA)**.
5. Upon receiving the INTA signal, the **interrupting device** is expected to return the **op-code** of one of the 8 RST instructions.

The 8085 Non-Vectored Interrupt Process

6. When the microprocessor executes the RST instruction received from the device, it **saves the address of the next instruction** on the stack and **jumps to the appropriate entry in the IVT**.
7. The **IVT entry** must **redirect** the microprocessor to the actual **service routine**.
8. The service routine must include the instruction **EI** to re-enable the interrupt process.
9. At the end of the service routine, the **RET** instruction **returns the execution to where the program was interrupted**.

The 8085 Non-Vectored Interrupt Process

- The 8085 recognizes 8 RESTART instructions: RST0 - RST7.
 - each of these would send the execution to a predetermined hard-wired memory location:

Restart Instruction	Equivalent to
RST0	CALL 0000H
RST1	CALL 0008H
RST2	CALL 0010H
RST3	CALL 0018H
RST4	CALL 0020H
RST5	CALL 0028H
RST6	CALL 0030H
RST7	CALL 0038H

Restart Sequence

- The restart sequence is made up of three machine cycles
 - In the 1st machine cycle:
 - The microprocessor sends the INTA signal.
 - While INTA is active the microprocessor reads the data lines expecting to receive, from the interrupting device, the opcode for the specific RST instruction.
 - In the 2nd and 3rd machine cycles:
 - the 16-bit address of the next instruction is saved on the stack.
 - Then the microprocessor jumps to the address associated with the specified RST instruction.

Restart Sequence

- The location in the IVT associated with the RST instruction can not hold the complete service routine.
 - The routine is written somewhere else in memory.
 - Only a JUMP instruction to the ISR's location is kept in the IVT block.

Hardware Generation of RST Opcode

- How does the external device produce the opcode for the appropriate RST instruction?
 - The opcode is simply a collection of bits.
 - So, the device needs to set the bits of the data bus to the appropriate value in response to an INTA signal.

Hardware Generation of RST

The following is an example of generating RST 5:

Opcode

Tri-state Buffer

RST 5's opcode is EF =

D	D
7	6
6	5
5	4
4	3
3	2
2	1
1	0
1	1
1	1
1	1

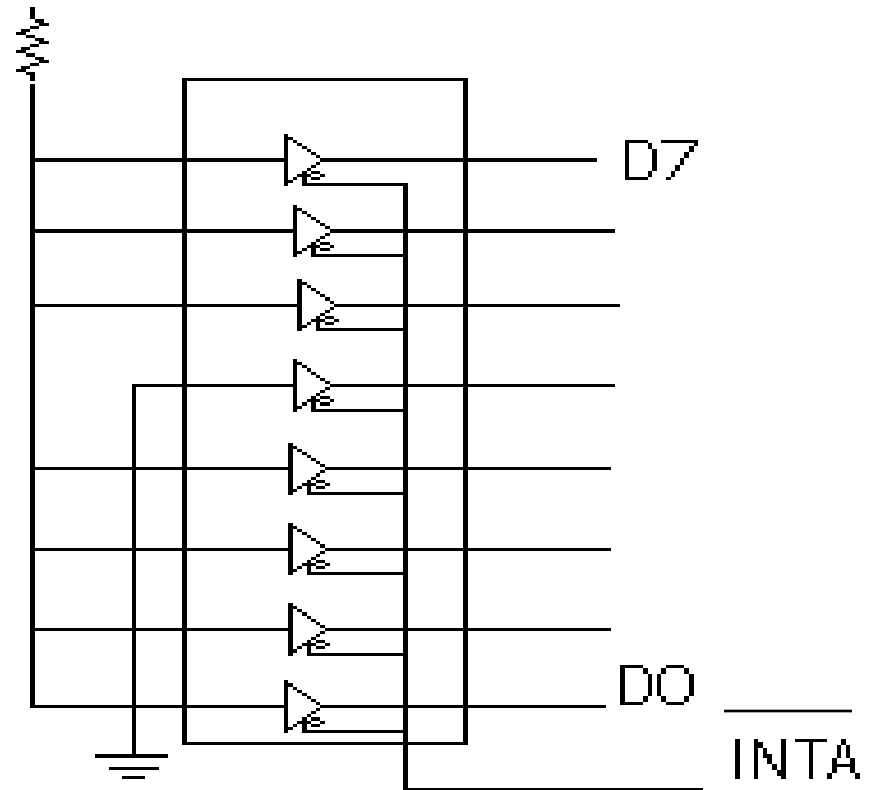

Hardware Generation of RST Opcode

- During the interrupt acknowledge machine cycle, (the 1st machine cycle of the RST operation):
 - The Microprocessor activates the INTA signal.
 - This signal will enable the Tri-state buffers, which will place the value EFH on the data bus.
 - Therefore, sending the Microprocessor the RST 5 instruction.
- The RST 5 instruction is exactly equivalent to CALL 0028H

Issues in Implementing INTR Interrupts

- How long must INTR remain high?
 - The microprocessor checks the INTR line one clock cycle before the last T-state of each instruction.
 - The interrupt process is Asynchronous.
 - The INTR must remain active long enough to allow for the longest instruction.
 - The longest instruction for the 8085 is the conditional CALL instruction which requires 18 T-states.

Therefore, the INTR must remain active for 17.5 T-states.

Issues in Implementing INTR Interrupts

- How long can the INTR remain high?
 - The INTR line must be deactivated before the EI is executed. Otherwise, the microprocessor will be interrupted again.
 - The worst case situation is when EI is the first instruction in the ISR.
 - Once the microprocessor starts to respond to an INTR interrupt, INTA becomes active (=0).

Therefore, INTR should be turned off as soon as the INTA signal is received.

Issues in Implementing INTR Interrupts

- Can the microprocessor be interrupted again before the completion of the ISR?
 - As soon as the 1st interrupt arrives, all maskable interrupts are disabled.
 - They will only be enabled after the execution of the EI instruction.

Therefore, the answer is: “only if you allow it to”.
If the EI instruction is placed early in the ISR, other interrupt may occur before the ISR is done.

Multiple Interrupts & Priorities

- How do we allow multiple devices to interrupt using the INTR line?
 - The microprocessor can only respond to one signal on INTR at a time.
 - Therefore, we must allow the signal from only one of the devices to reach the microprocessor.
 - We must assign some priority to the different devices and allow their signals to reach the microprocessor according to the priority.

The Priority Encoder

- The solution is to use a circuit called the priority encoder (74366).
 - This circuit has 8 inputs and 3 outputs.
 - The inputs are assigned increasing priorities according to the increasing index of the input.
 - Input 7 has highest priority and input 0 has the lowest.
 - The 3 outputs carry the index of the highest priority active input.
 - Figure 12.4 in the book shows how this circuit can be used with a Tri-state buffer to implement an interrupt priority scheme.
 - The figure in the textbook does not show the method for distributing the INTA signal back to the individual devices.

Multiple Interrupts & Priorities

- Note that the opcodes for the different RST instructions follow a set pattern.
 - Bit D5, D4 and D3 of the opcodes change in a binary sequence from RST 7 down to RST 0.
 - The other bits are always 1.
 - This allows the code generated by the 74366 to be used directly to choose the appropriate RST instruction.
- The one draw back to this scheme is that the only way to change the priority of the devices connected to the 74366 is to reconnect the hardware.

Multiple Interrupts and Priority

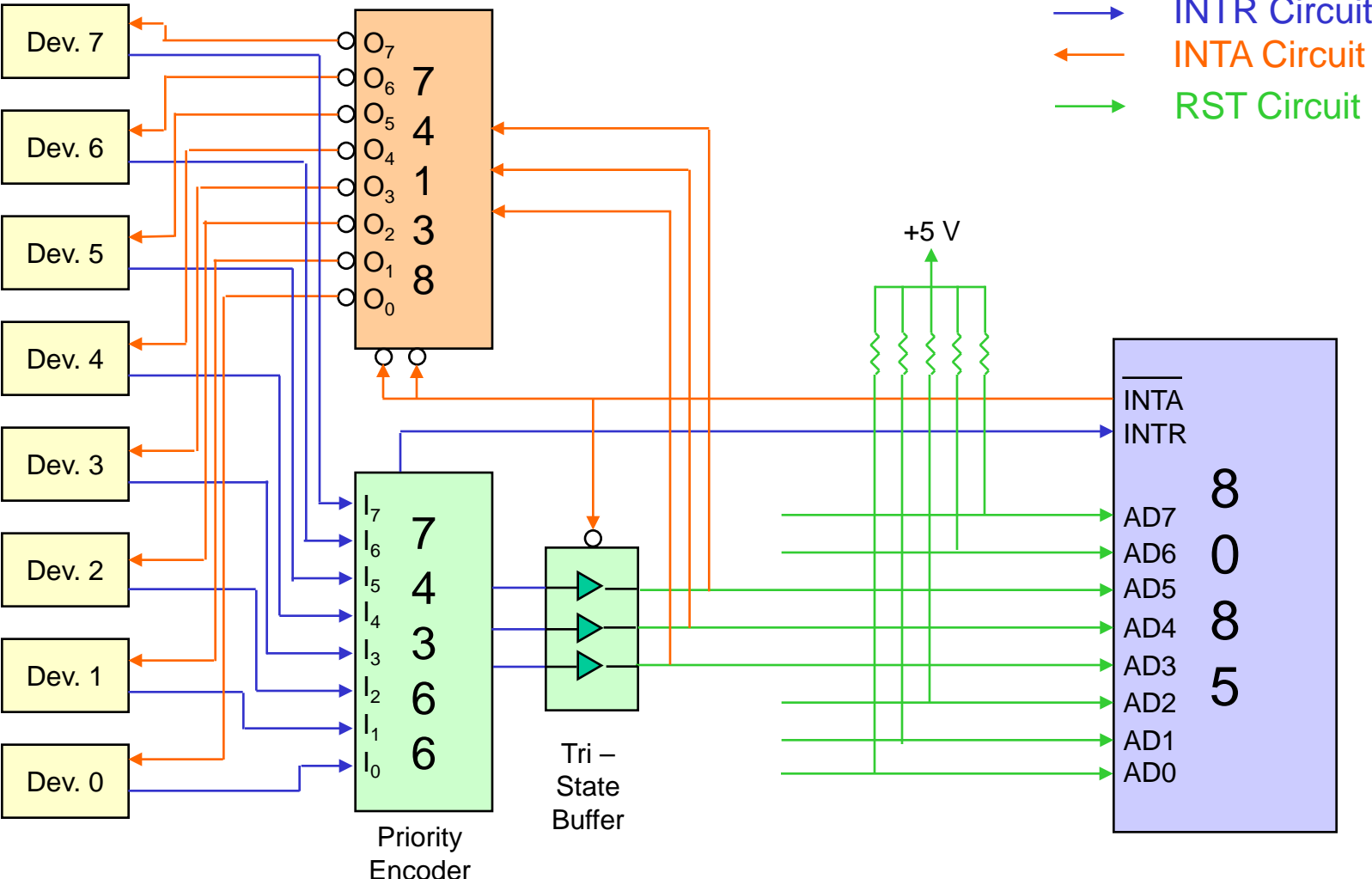

The 8085 Maskable/Vectored Interrupts

- The 8085 has 4 Masked/Vectored interrupt inputs.
 - RST 5.5, RST 6.5, RST 7.5
 - They are all **maskable**.
 - They are **automatically vectored** according to the following table:

Interrupt	Vector
RST 5.5	002CH
RST 6.5	0034H
RST 7.5	003CH

- The vectors for these interrupt fall in between the vectors for the RST instructions. That's why they have names like RST 5.5 (RST 5 and a half).

Masking RST 5.5, RST 6.5 and RST 7.5

- These three interrupts are masked at two levels:
 - Through the Interrupt Enable flip flop and the EI/DI instructions.
 - The Interrupt Enable flip flop controls the whole maskable interrupt process.
 - Through individual mask flip flops that control the availability of the individual interrupts.
 - These flip flops control the interrupts individually.

Maskable Interrupts

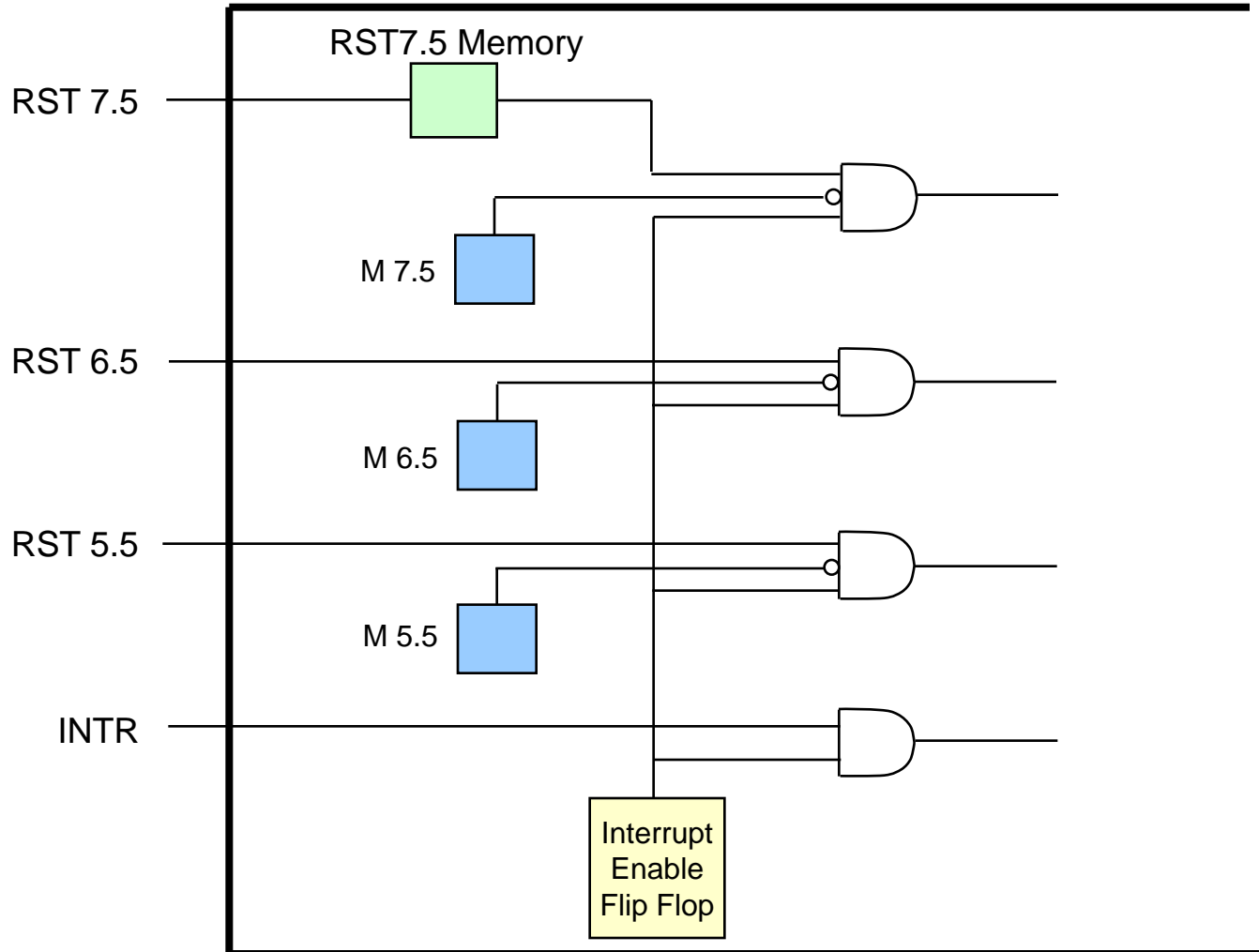

The 8085 Maskable/Vectored Interrupt Process

1. The interrupt process should be **enabled** using the **EI** instruction.
2. The 8085 checks for an interrupt during the execution of **every** instruction.
3. If there is an interrupt, and if the interrupt is enabled using the interrupt mask, the microprocessor will **complete the executing instruction**, and **reset the interrupt flip flop**.
4. The microprocessor then executes a call instruction that sends the execution to the **appropriate** location in the interrupt vector table.

The 8085 Maskable/Vectored Interrupt Process

5. When the microprocessor executes the call instruction, it **saves the address of the next instruction** on the stack.
6. The microprocessor **jumps to the specific service routine**.
7. The service routine must include the instruction **EI** to re-enable the interrupt process.
8. At the end of the service routine, the **RET** instruction **returns the execution to where the program was interrupted**.

Manipulating the Masks

- The Interrupt Enable flip flop is manipulated using the EI/DI instructions.
- The individual **masks** for RST 5.5, RST 6.5 and RST 7.5 are manipulated using the **SIM** instruction.
 - This instruction takes the bit pattern in the Accumulator and applies it to the interrupt mask enabling and disabling the specific interrupts.

How SIM Interprets the Accumulator

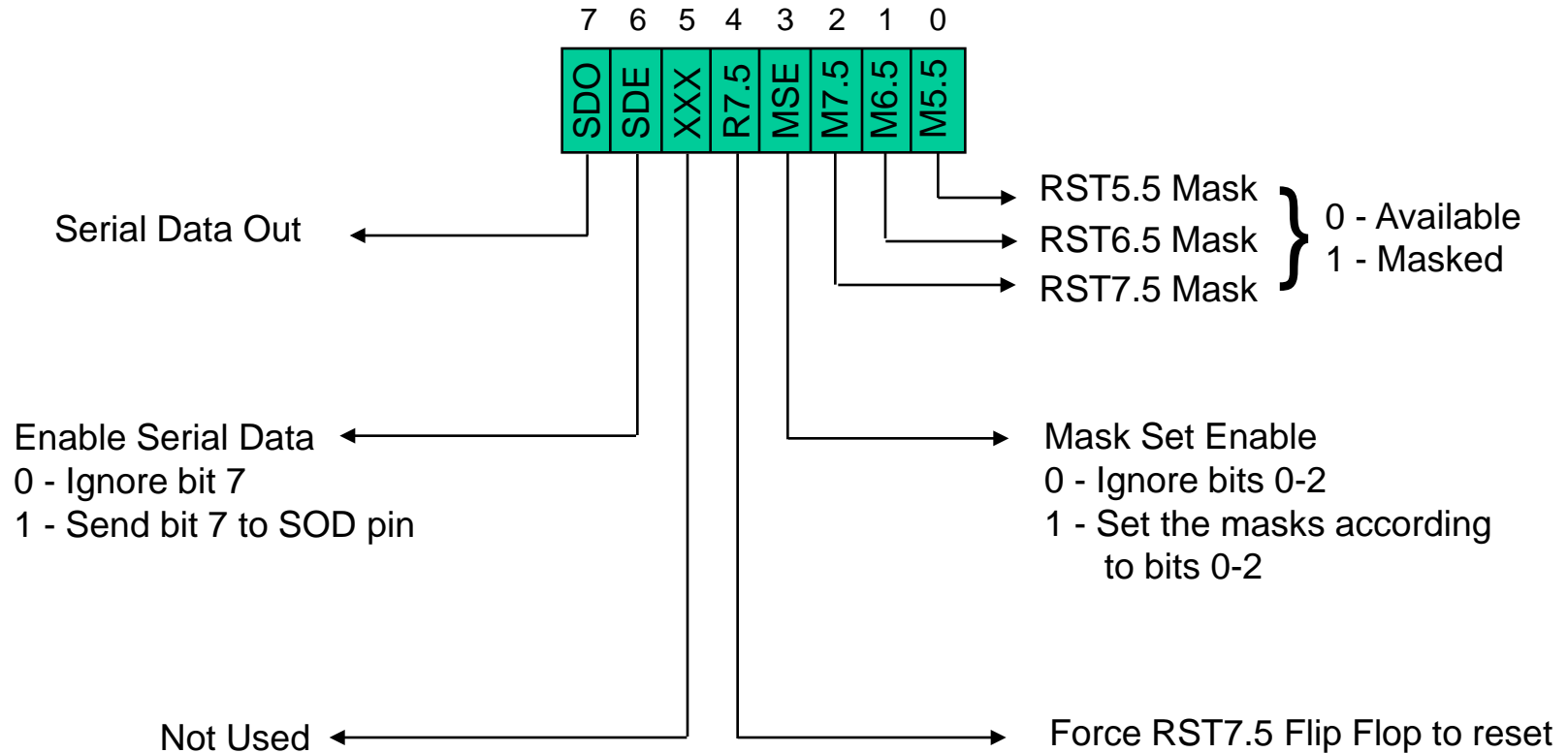

SIM and the Interrupt Mask

- Bit 0 is the **mask** for RST 5.5, bit 1 is the **mask** for RST 6.5 and bit 2 is the **mask** for RST 7.5.
 - If the mask bit is 0, the interrupt is **available**.
 - If the mask bit is 1, the interrupt is **masked**.
- Bit 3 (Mask Set Enable - MSE) is an **enable for setting the mask**.
 - If it is set to 0 the mask is **ignored** and the old settings remain.
 - If it is set to 1, the new settings are **applied**.
 - The SIM instruction is used for multiple purposes and not only for setting interrupt masks.
 - **It is also used to control functionality such as Serial Data Transmission.**
 - **Therefore, bit 3 is necessary to tell the microprocessor whether or not the interrupt masks should be modified**

SIM and the Interrupt Mask

- The RST 7.5 interrupt is the **only** 8085 interrupt that has **memory**.
 - If a signal on RST7.5 arrives while it is masked, a flip flop will remember the signal.
 - When RST7.5 is unmasked, the microprocessor will be interrupted **even if the device has removed the interrupt signal**.
 - This flip flop will be **automatically reset** when the microprocessor responds to an RST 7.5 interrupt.
- Bit 4 of the accumulator in the SIM instruction allows **explicitly resetting** the RST 7.5 memory even if the microprocessor did not respond to it.

SIM and the Interrupt Mask

- The SIM instruction can also be used to perform serial data transmission out of the 8085's SOD pin.
 - One bit at a time can be sent out serially over the SOD pin.
- Bit 6 is used to tell the microprocessor whether or not to perform serial data transmission
 - If 0, then do not perform serial data transmission
 - If 1, then do.
- The value to be sent out on SOD has to be placed in bit 7 of the accumulator.
- Bit 5 is not used by the SIM instruction

Using the SIM Instruction to Modify the Interrupt Masks

- Example: Set the interrupt masks so that RST5.5 is enabled, RST6.5 is masked, and RST7.5 is enabled.
 - First, determine the contents of the accumulator

- | | |
|-----------------------------|-----------|
| - Enable 5.5 | bit 0 = 0 |
| - Disable 6.5 | bit 1 = 1 |
| - Enable 7.5 | bit 2 = 0 |
| - Allow setting the masks | bit 3 = 1 |
| - Don't reset the flip flop | bit 4 = 0 |
| - Bit 5 is not used | bit 5 = 0 |
| - Don't use serial data | bit 6 = 0 |
| - Serial data is ignored | bit 7 = 0 |

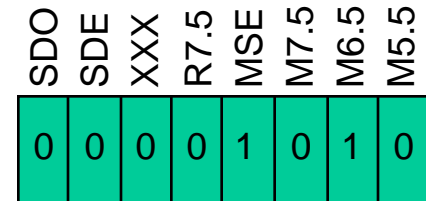

Contents of accumulator are: 0AH

```
EI          ; Enable interrupts including INTR
MVI A, 0A   ; Prepare the mask to enable RST 7.5, and 5.5, disable 6.5
SIM        ; Apply the settings RST masks
```

Triggering Levels

- RST 7.5 is **positive edge sensitive**.
 - When a positive edge appears on the RST7.5 line, a logic 1 is **stored** in the flip-flop as a “**pending**” interrupt.
 - Since the value has been stored in the flip flop, the line **does not have to be high** when the microprocessor checks for the interrupt to be recognized.
 - The line must **go to zero and back to one** before a new interrupt is recognized.
- RST 6.5 and RST 5.5 are **level sensitive**.
 - The interrupting signal **must remain present until the microprocessor checks for interrupts**.

Determining the Current Mask Settings

- RIM instruction: Read Interrupt Mask
 - Load the **accumulator** with an 8-bit pattern showing the status of each interrupt pin and mask.

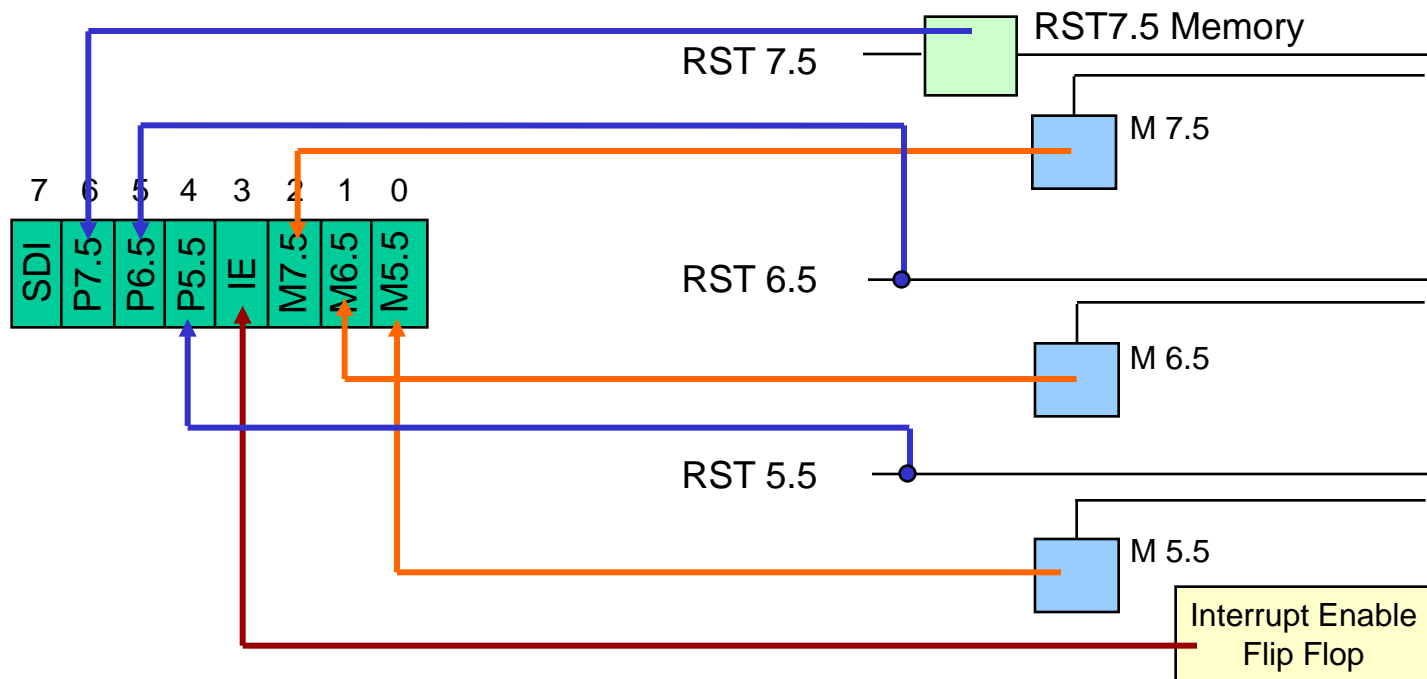

How RIM sets the Accumulator's different bits

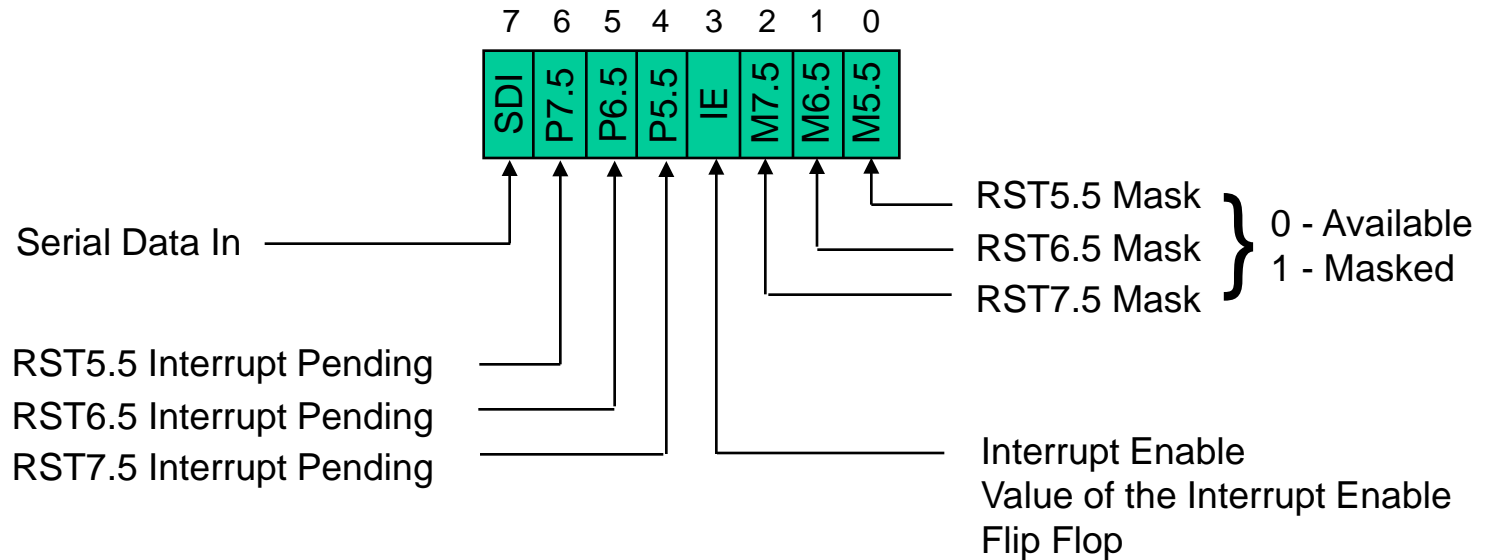

The RIM Instruction and the Masks

- Bits 0-2 show the current **setting of the mask** for each of RST 7.5, RST 6.5 and RST 5.5
 - They return the contents of the three mask flip flops.
 - They can be used by a program to read the mask settings in order to modify only the right mask.
- Bit 3 shows whether the maskable interrupt process is **enabled or not**.
 - It returns the contents of the Interrupt Enable Flip Flop.
 - It can be used by a program to determine whether or not interrupts are enabled.

The RIM Instruction and the Masks

- Bits 4-6 show whether or not there are **pending interrupts** on RST 7.5, RST 6.5, and RST 5.5
 - Bits 4 and 5 return the current value of the RST5.5 and RST6.5 **pins**.
 - Bit 6 returns the current value of the RST7.5 memory **flip flop**.
- Bit 7 is used for **Serial Data Input**.
 - The RIM instruction reads the value of the **SID pin** on the microprocessor and returns it in this bit.

Pending Interrupts

- Since the 8085 has five interrupt lines, interrupts may occur during an ISR and remain pending.
 - Using the **RIM** instruction, the programmer can read the status of the interrupt lines and find if there are any pending interrupts.
 - The advantage is being able to find about interrupts on RST 7.5, RST 6.5, and RST 5.5 without having to enable low level interrupts like INTR.

Using RIM and SIM to set Individual Masks

- Example: Set the mask to enable RST6.5 without modifying the masks for RST5.5 and RST7.5.
 - In order to do this correctly, we need to use the RIM instruction to find the current settings of the RST5.5 and RST7.5 masks.
 - Then we can use the SIM instruction to set the masks using this information.
 - Given that both RIM and SIM use the Accumulator, we can use some logical operations to mask the un-needed values returned by RIM and turn them into the values needed by SIM.

Using RIM and SIM to set Individual Masks

- Assume the RST5.5 and RST7.5 are enabled and the interrupt process is disabled.

RIM ; Read the current settings.

ORI 08H ; 00001000
; Set bit 4 for MSE.

ANI 0DH ; 00001101
; Turn off Serial Data, Don't reset
; RST7.5 flip flop, and set the mask
; for RST6.5 off. Don't cares are
; assumed to be 0.

SIM ; Apply the settings.

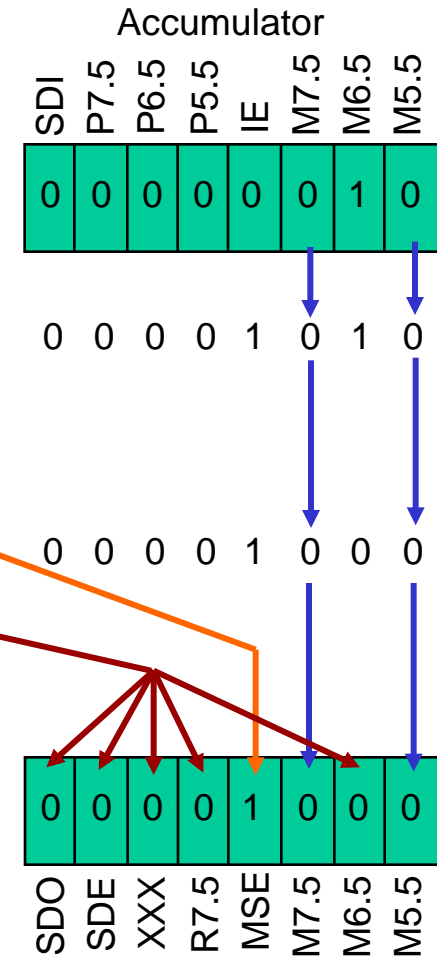

TRAP

- TRAP is the only **non-maskable** interrupt.
 - It does not need to be enabled because it **cannot be disabled**.
- It **has the highest priority** amongst interrupts.
- It is **edge and level sensitive**.
 - It needs to be high and stay high to be recognized.
 - Once it is recognized, it won't be recognized again until it goes low, then high again.
- TRAP is usually used for power failure and emergency shutoff.

Internal Interrupt Priority

- Internally, the 8085 implements an **interrupt priority scheme**.
 - The interrupts are ordered as follows:
 - TRAP
 - RST 7.5
 - RST 6.5
 - RST 5.5
 - INTR
 - However, TRAP has lower priority than the HLD signal used for DMA.

The 8085 Interrupts

Interrupt Name	Maskable	Masking Method	Vectored	Memory	Triggering Method
INTR	Yes	DI / EI	No	No	Level Sensitive
RST 5.5 / RST 6.5	Yes	DI / EI SIM	Yes	No	Level Sensitive
RST 7.5	Yes	DI / EI SIM	Yes	Yes	Edge Sensitive
TRAP	No	None	Yes	No	Level & Edge Sensitive

Additional Concepts and Processes

- Programmable Interrupt Controller 8259 A
 - A programmable interrupt managing device
 - It manages 8 interrupt requests.
 - It can vector an interrupt **anywhere** in memory **without additional H/W**.
 - It can support **8 levels** of interrupt **priorities**.
 - The priority scheme **can be extended to 64 levels** using a hierarchy of 8259 device.

The Need for the 8259A

- The 8085 INTR interrupt scheme presented earlier has a few limitations:
 - The RST instructions are all vectored to memory page **00H**, which is usually **used for ROM**.
 - It requires **additional hardware** to produce the RST instruction opcodes.
 - Priorities are **set by hardware**.
- Therefore, we need a device like the 8259A to expand the priority scheme and allow mapping to pages other than 00H.

Interfacing the 8259A to the 8085

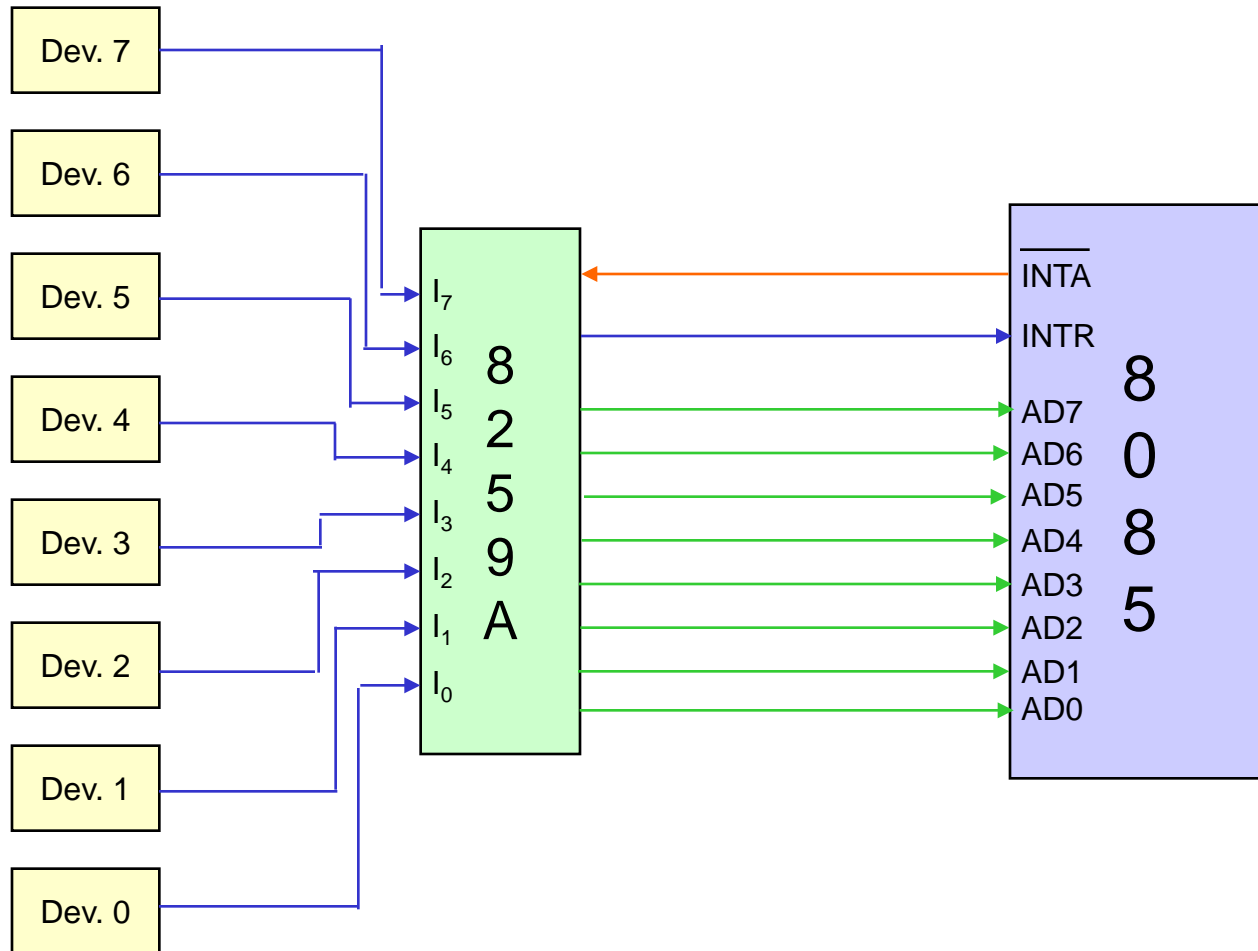

Operating of the 8259A

- The 8259A requires the microprocessor to provide 2 control words to set up its operation. After that, the following sequence occurs:
 1. One or more interrupts come in.
 2. The 8259A resolves the interrupt priorities based on its internal settings
 3. The 8259A sends an **INTR** signal to the microprocessor.
 4. The microprocessor responds with an **INTA** signal and **turns off** the interrupt enable flip flop.
 5. The 8259A responds by placing the op-code for the **CALL instruction (CDH)** on the data bus.

Operating of the 8259A

6. When the microprocessor receives the op-code for **CALL instead of RST**, it recognizes that the device will be sending **16 more bits** for the address.
7. The microprocessor sends **a second INTA** signal.
8. The 8259A sends the **high order byte** of the ISR's address.
9. The microprocessor sends **a third INTA** signal.
10. The 8259A sends the **low order byte** of the ISR's address.
11. The microprocessor executes the **CALL instruction** and jumps to the ISR.

Direct Memory Access

- This is a process where data is transferred between two peripherals directly without the involvement of the microprocessor.
 - This process employs the HOLD pin on the microprocessor
 - The external DMA controller sends a signal on the HOLD pin to the microprocessor.
 - The microprocessor completes the current operation and sends a signal on HLDA and stops using the buses.
 - Once the DMA controller is done, it turns off the HOLD signal and the microprocessor takes back control of the buses.

Serial I/O and Data Communication

Basic Concepts in Serial I/O

- Interfacing requirements:
 - Identify the device through a port number.
 - Memory-mapped.
 - Peripheral-mapped.
 - Enable the device using the Read and Write control signals.
 - Read for an input device.
 - Write for an output device.
 - Only one data line is used to transfer the information instead of the entire data bus.

Basic Concepts in Serial I/O

- Controlling the transfer of data:
 - Microprocessor control.
 - Unconditional, polling, status check, etc.
 - Device control.
 - Interrupt.

Synchronous Data Transmission

- The transmitter and receiver are synchronized.
 - A sequence of synchronization signals is sent before the communication begins.
- Usually used for high speed transmission.
 - More than 20 K bits/sec.
- Message based.
 - Synchronization occurs at the beginning of a long message.

Asynchronous Data Transmission

- Transmission occurs at any time.
- Character based.
 - Each character is sent separately.
- Generally used for low speed transmission.
 - Less the 20 K bits/sec.

Asynchronous Data Transmission

- Follows agreed upon standards:
 - The line is normally at logic one (mark).
 - Logic 0 is known as space.
 - The transmission begins with a start bit (low).
 - Then the seven or eight bits representing the character are transmitted.
 - The transmission is concluded with one or two stop bits.

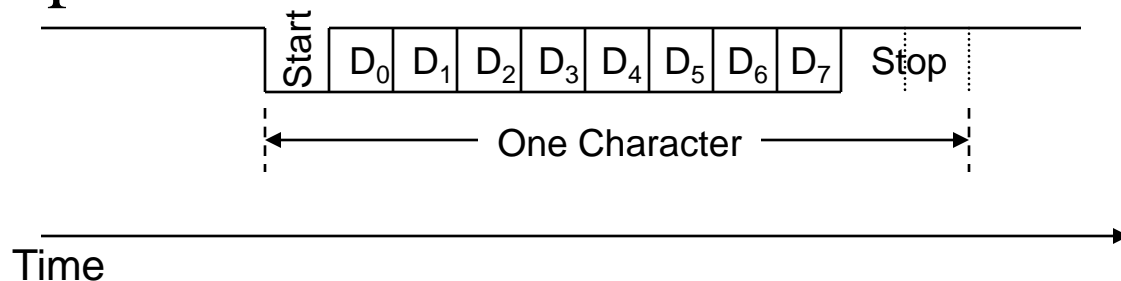

Simplex and Duplex Transmission

- Simplex.
 - One-way transmission.
 - Only one wire is needed to connect the two devices
 - Like communication from computer to a printer.
- Half-Duplex.
 - Two-way transmission but one way at a time.
 - One wire is sufficient.
- Full-Duplex.
 - Data flows both ways at the same time.
 - Two wires are needed.
 - Like transmission between two computers.

Rate of Transmission

- For parallel transmission, all of the bits are sent at once.
- For serial transmission, the bits are sent one at a time.
 - Therefore, there needs to be agreement on how “long” each bit stays on the line.
- The rate of transmission is usually measured in bits/second or baud.

Length of Each Bit

- Given a certain baud rate, how long should each bit last?
 - Baud = bits / second.
 - Seconds / bits = 1 /baud.
 - At 1200 baud, a bit lasts $1/1200 = 0.83$ m Sec.

Transmitting a Character

- To send the character A over a serial communication line at a baud rate of 56.6 K:
 - ASCII for A is 41H = 01000001.
 - Must add a start bit and two stop bits:
 - 11 01000001 0
 - Each bit should last $1/56.6\text{K} = 17.66 \mu \text{Sec}$.
 - Known as bit time.
 - Set up a delay loop for $17.66 \mu \text{Sec}$ and set the transmission line to the different bits for the duration of the loop.

Error Checking

- Various types of errors may occur during transmission.
 - To allow checking for these errors, additional information is transmitted with the data.
- Error checking techniques:
 - Parity Checking.
 - Checksum.
- These techniques are for error checking not correction.
 - They only indicate that an error has occurred.
 - They do not indicate where or what the correct information is.

Parity Checking

- Make the number of 1's in the data Odd or Even.
 - Given that ASCII is a 7-bit code, bit D_7 is used to carry the parity information.
- Even Parity
 - The transmitter counts the number of ones in the data. If there is an odd number of 1's, bit D_7 is set to 1 to make the total number of 1's even.
 - The receiver calculates the parity of the received message, it should match bit D_7 .
 - If it doesn't match, there was an error in the transmission.

Checksum

- Used when larger blocks of data are being transmitted.
- The transmitter adds all of the bytes in the message without carries. It then calculates the 2's complement of the result and send that as the last byte.
- The receiver adds all of the bytes in the message including the last byte. The result should be 0.
 - If it isn't an error has occurred.

RS 232

- A communication standard for connecting computers to printers, modems, etc.
 - The most common communication standard.
 - Defined in the 1950's.
 - It uses voltages between +15 and -15 V.
 - Restricted to speeds less than 20 K baud.
 - Restricted to distances of less than 50 feet (15 m).
- The original standard uses 25 wires to connect the two devices.
 - However, in reality only three of these wires are needed.

Software-Controlled Serial Transmission

- The main steps involved in serially transmitting a character are:
 - Transmission line is at logic 1 by default.
 - Transmit a start bit for one complete bit length.
 - Transmit the character as a stream of bits with appropriate delay.
 - Calculate parity and transmit it if needed.
 - Transmit the appropriate number of stop bits.
 - Transmission line returns to logic 1.

Serial Transmission

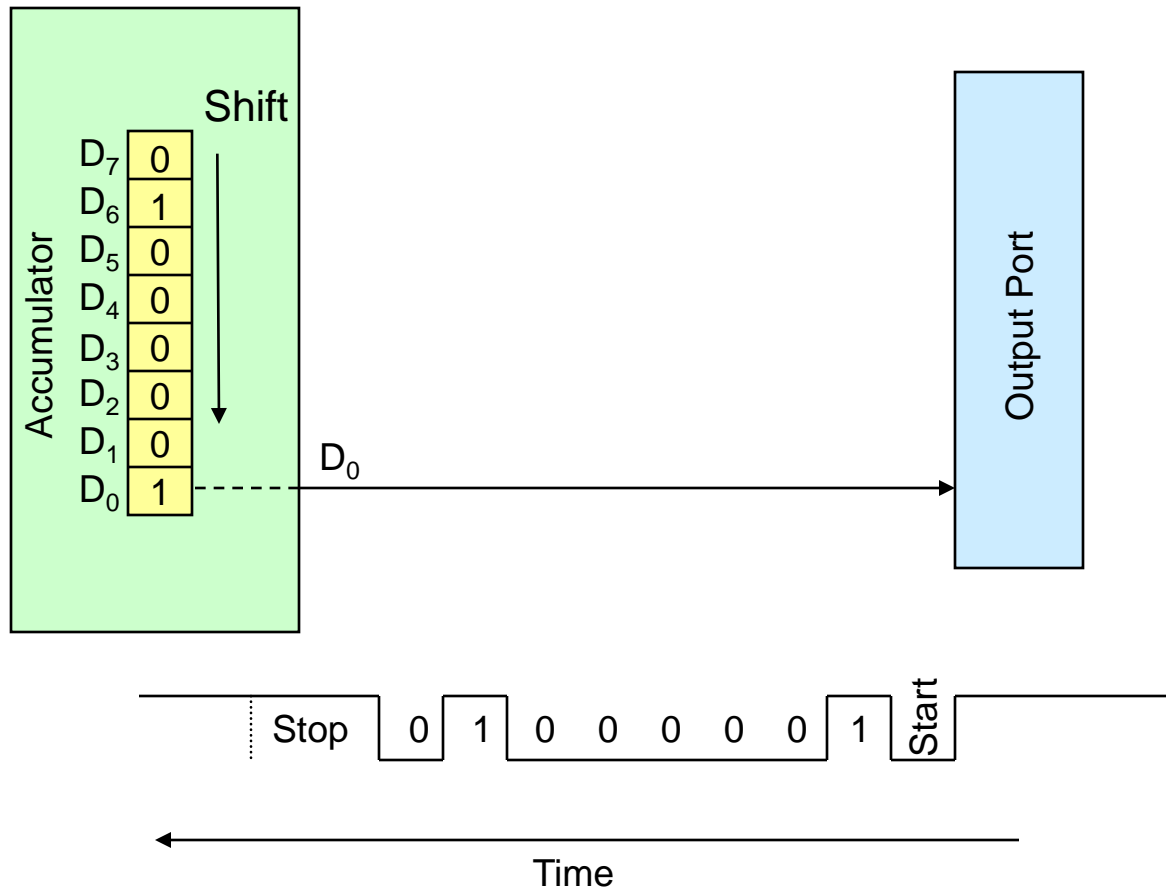

Flowchart of Serial Transmission

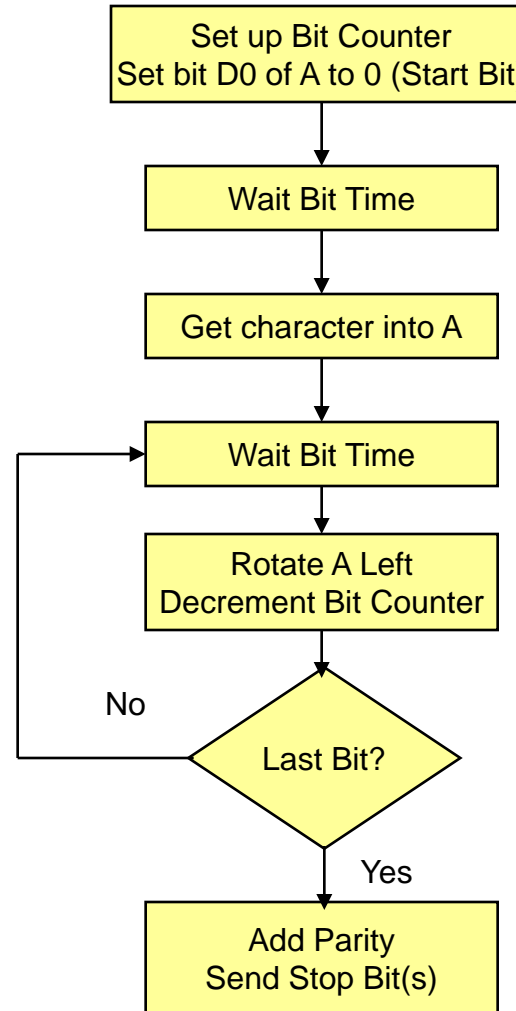

Software-Controlled Serial Reception

- The main steps involved in serial reception are:
 - Wait for a low to appear on the transmission line.
 - Start bit
 - Read the value of the line over the next 8 bit lengths.
 - The 8 bits of the character.
 - Calculate parity and compare it to bit 8 of the character.
 - Only if parity checking is being used.
 - Verify the reception of the appropriate number of stop bits.

Serial Reception

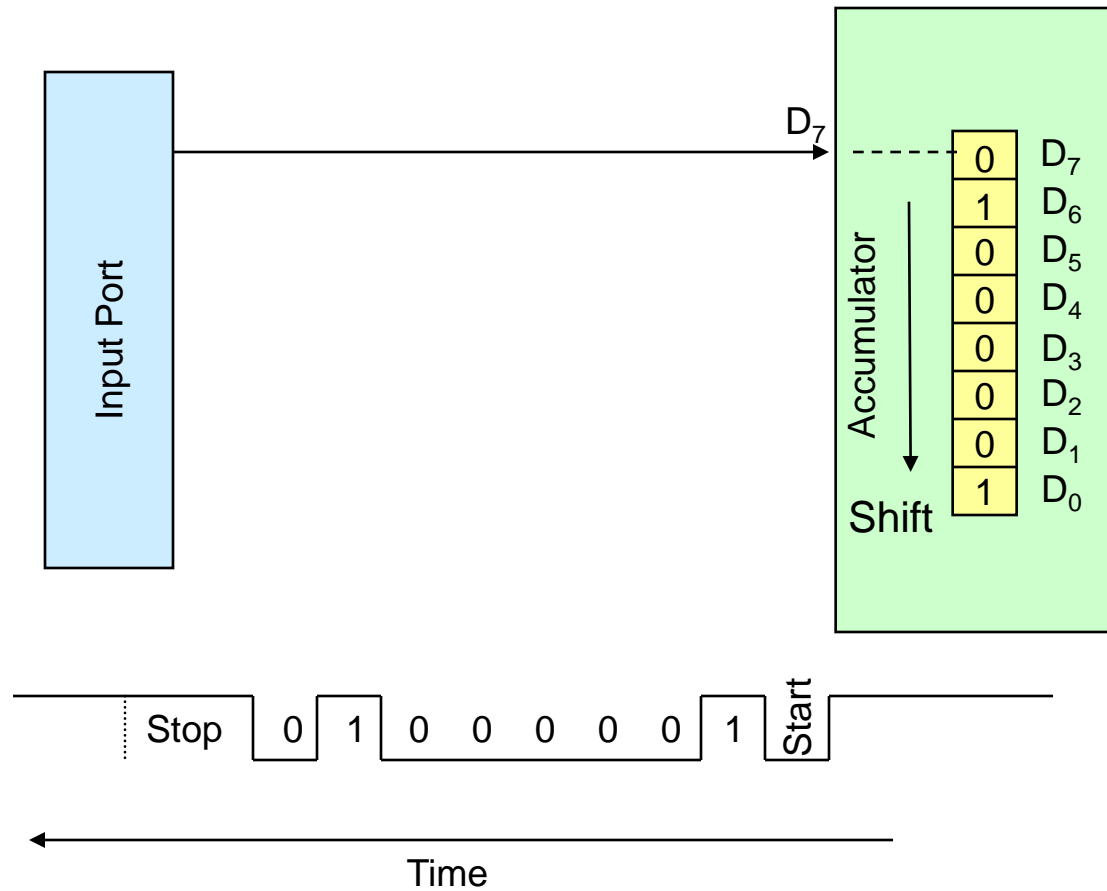

Flowchart of Serial Reception

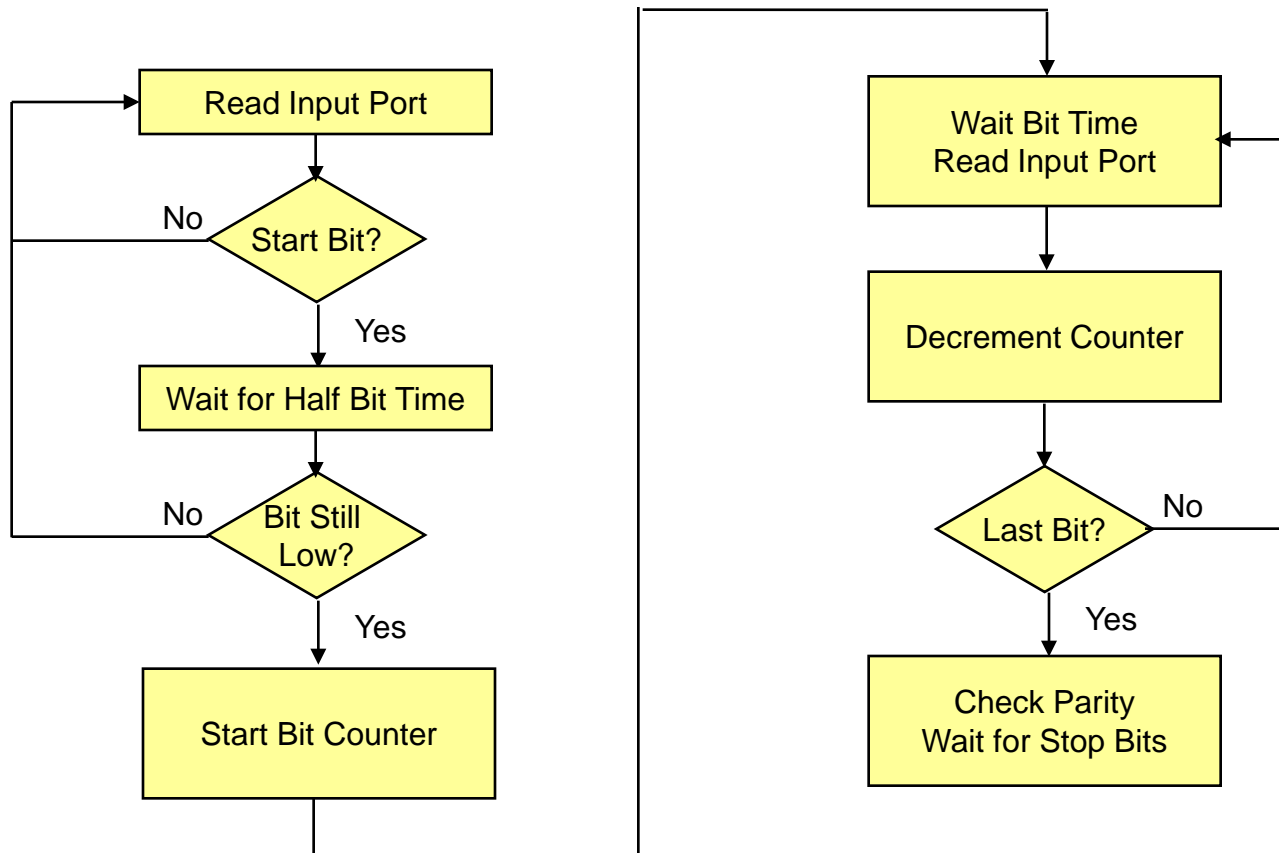

The 8085 Serial I/O Lines

- The 8085 Microprocessor has two serial I/O pins:
 - SOD – Serial Output Data
 - SID – Serial Input Data
- Serial input and output is controlled using the RIM and SIM instructions respectively.

SIM and Serial Output

- As was discussed in Chapter 12, the SIM instruction has dual use.
 - It is used for controlling the maskable interrupt process
 - For the serial output process.
- The figure below shows how SIM uses the accumulator for Serial Output.

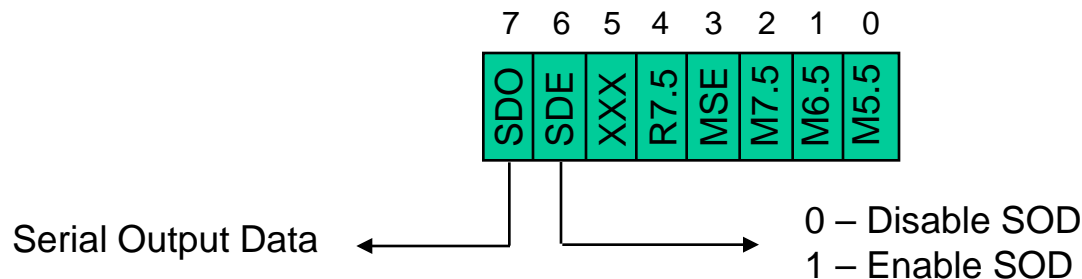

RIM and Serial Input

- Again, the RIM instruction has dual use
 - Reading the current settings of the Interrupt Masks
 - Serial Data Input

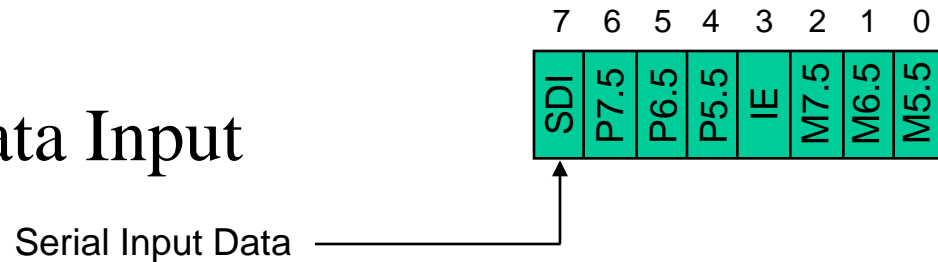

- The figure below shows how the RIM instruction uses the Accumulator for Serial Input

Ports?

- Using the SOD and SID pins, the user would not need to bother with setting up input and output ports.
 - The two pins themselves can be considered as the ports.
 - The instructions SIM and RIM are similar to the OUT and IN instructions except that they only deal with the 1-bit SOD and SID ports.

Example

- Transmit an ASCII character stored in register B using the SOD line.

```
SODDATA      MVI    C, 0BH    ; Set up counter for 11 bits
              XRA    A      ; Clear the Carry flag
NXTBIT       MVI    A, 80H  ; Set D7 =1
              RAR                ; Bring Carry into D7 and set D6 to 1
              SIM                ; Output D7 (Start bit)
              CALL   BITTIME
              STC                ; Set Carry to 1
              MOV    A, B      ; Place character in A
              RAR                ; Shift D0 of the character to the carry
                               ; Shift 1 into bit D7
              MOV    B, A      ; Save the interim result
              DCR    C         ; decrement bit counter
              JNZ    NXTBIT
```

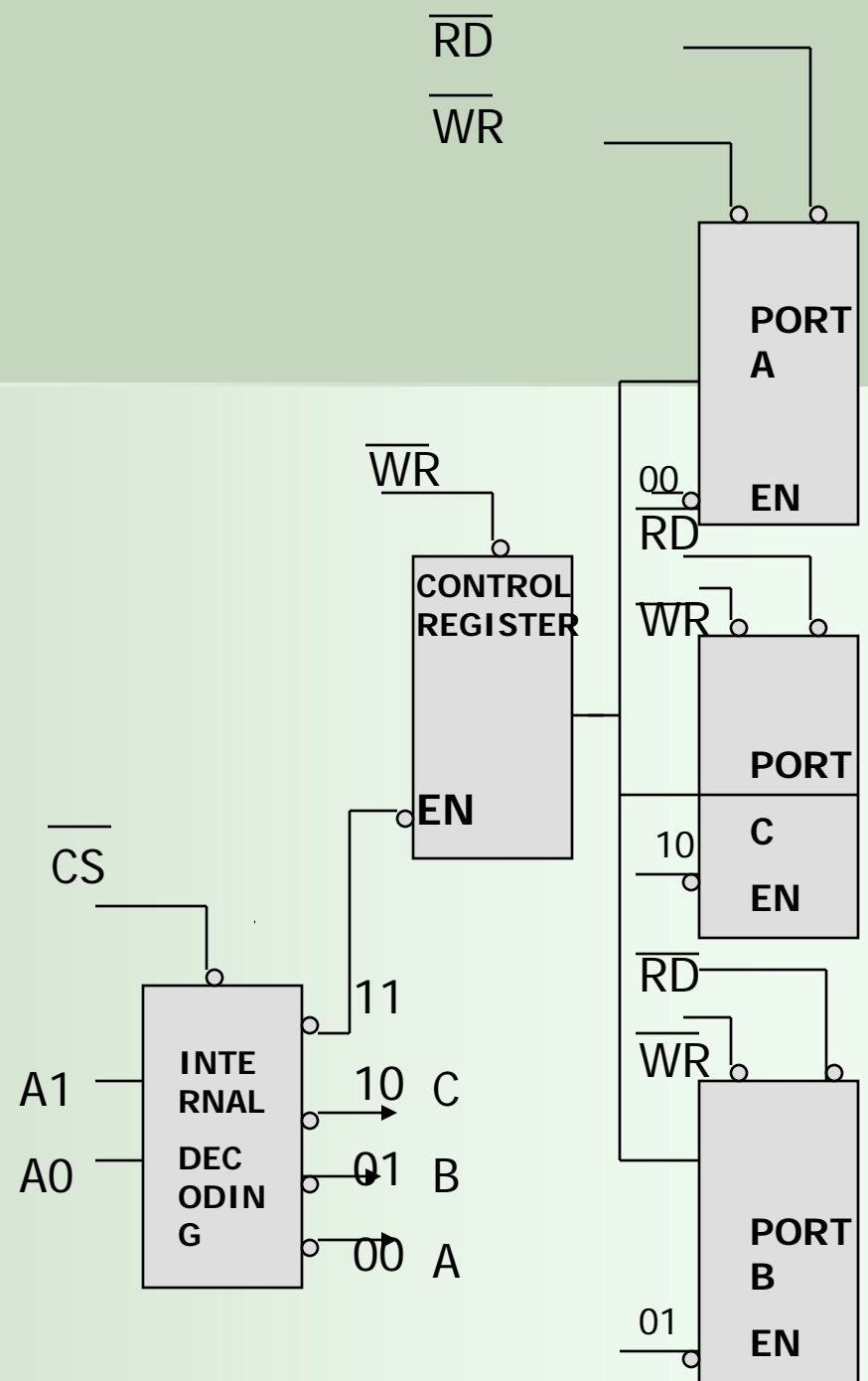
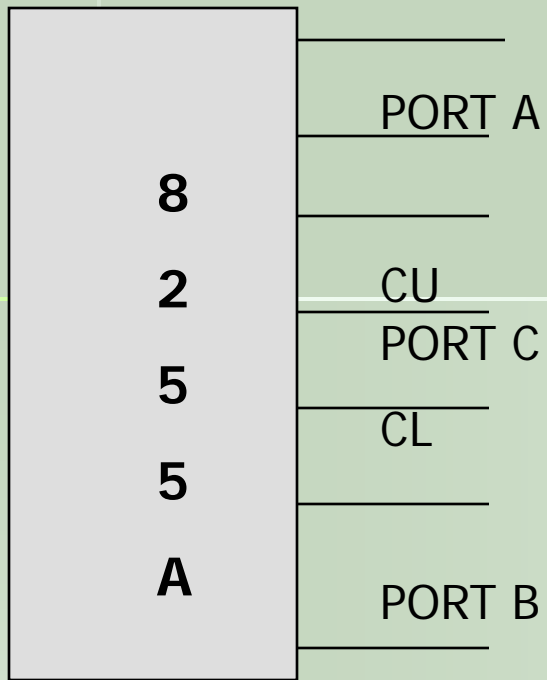

CONTROL WORD

D7 D6 D5 D4 D3 D2 D1 D0

0/1

BSR MODE

BIT SET/RESET

FOR PORT C

NO EFFECT ON I/O

MODE

I/O MODE

MODE 0

SIMPLE I/O FOR
PORTS

A, B AND C

MODE 1

HANDSHAKE
I/O FOR
PORTS A
AND/OR B

PORT C BITS
ARE USED
FOR
HANDSHAKE

MODE 2

BIDIRECTI
ONAL
DATA BUS
FOR PORT
A

PORT B
EITHER IN
MODE 0 OR
1

PORT C
BITS ARE
USED FOR
HANDSHAK
E

8255A

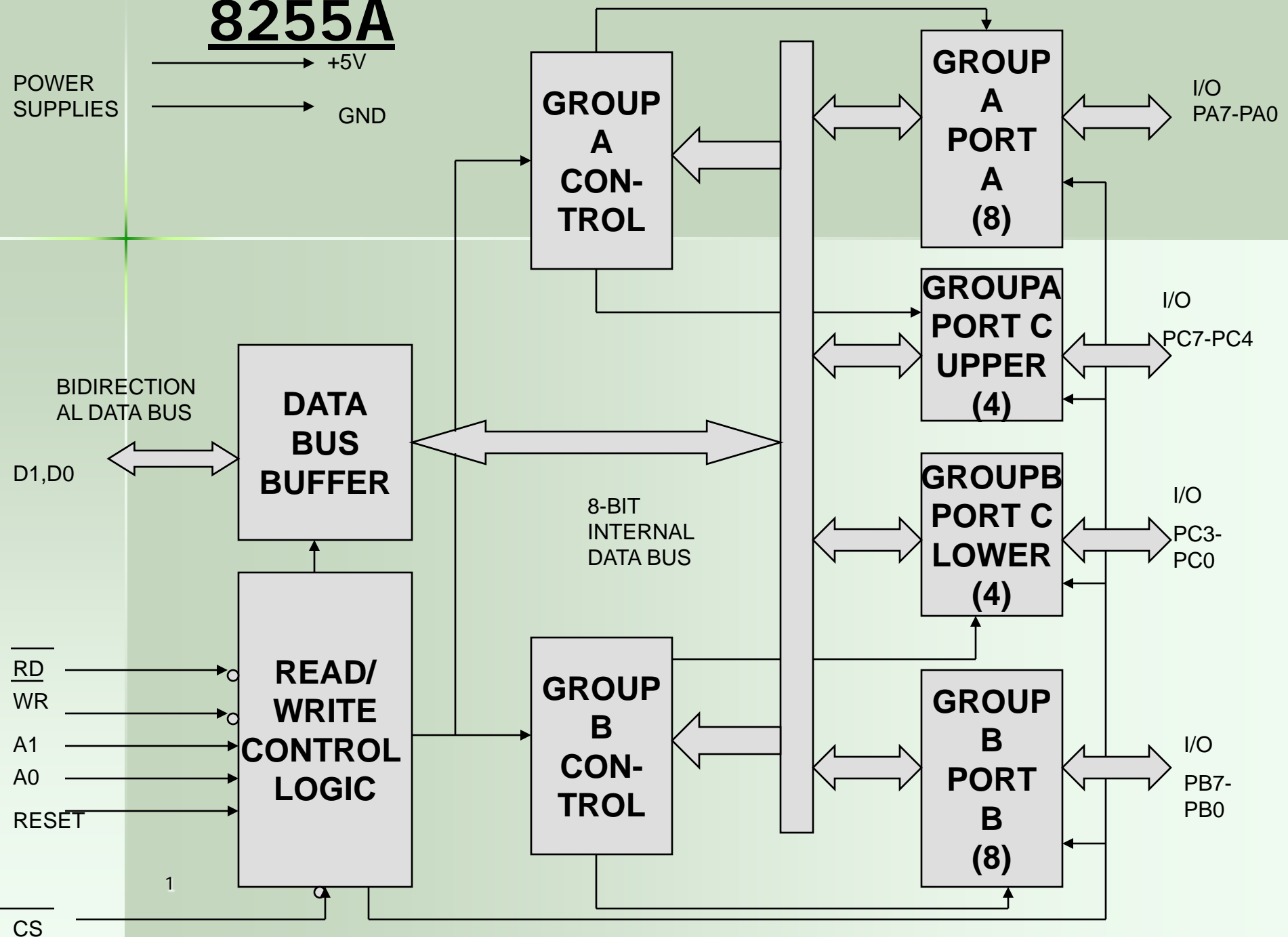

Control Word Format for I/O Mode

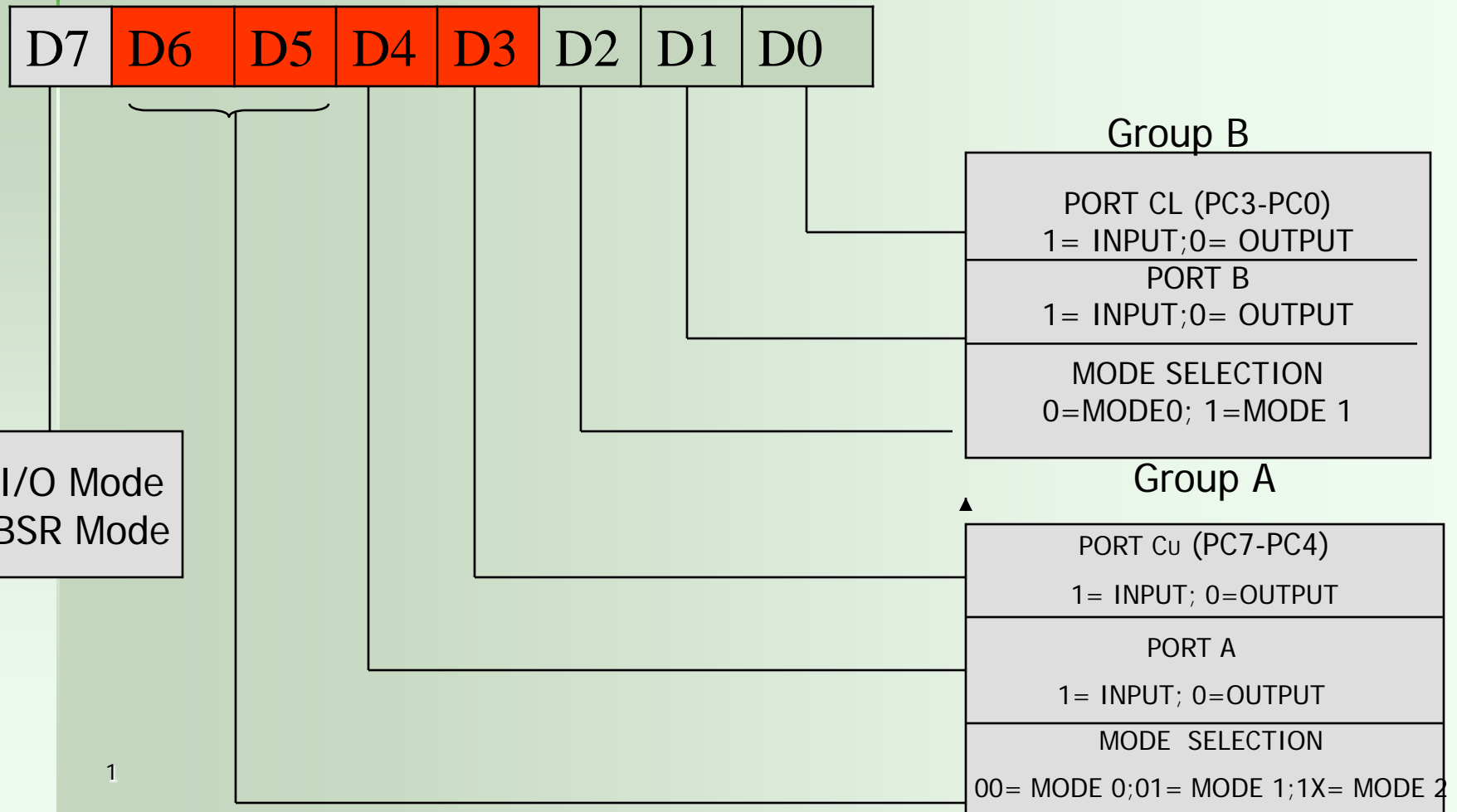

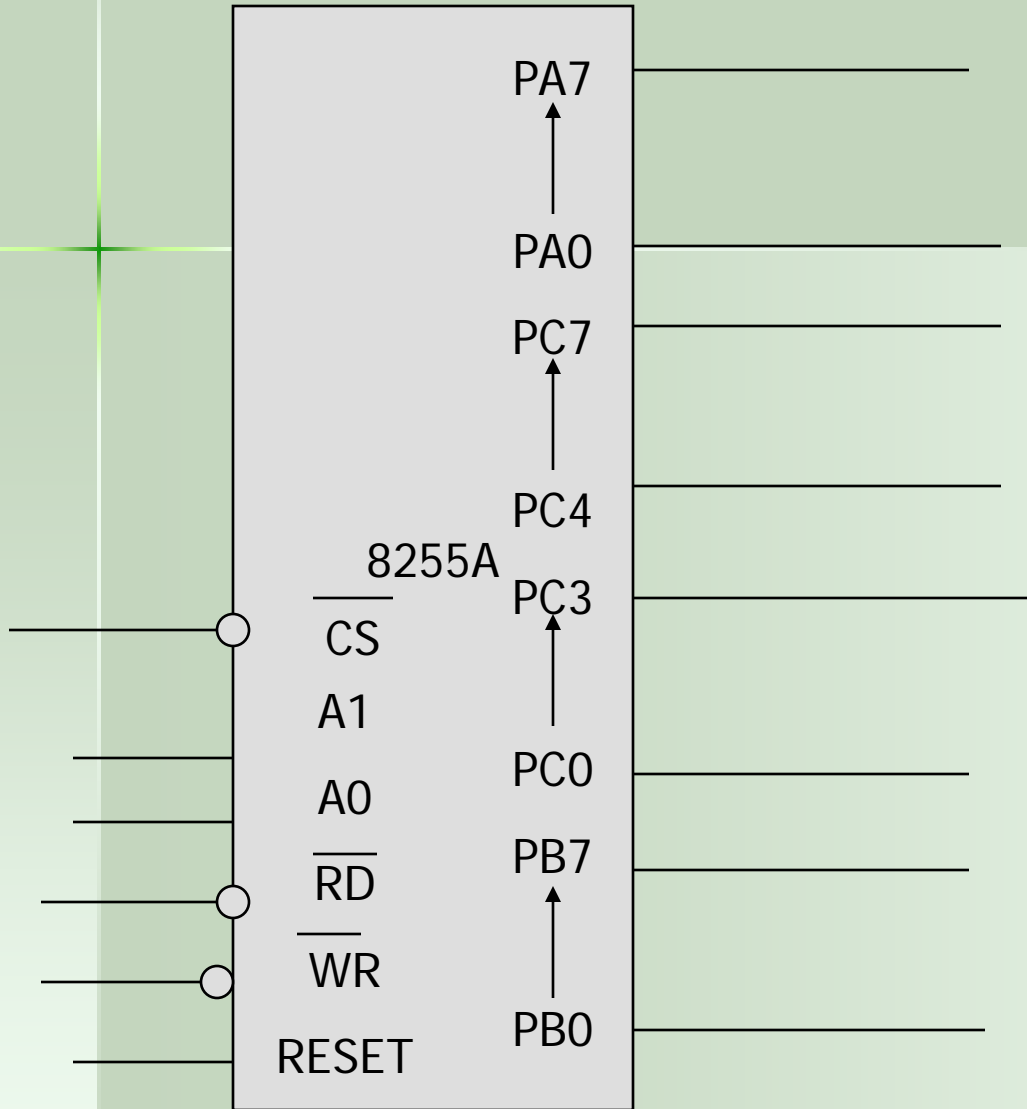

Mode 0 (Simple Input or Output)

PROBLEM 1)

- Interface 8255a to a 8085 microprocessor using I/O-mapped - I/O technique so that Port a have address 80H in the system.
- Determine addresses of Ports B,C and control register.
- Write an ALP to configure port A and port C_L as output ports and port B and port C_U as input ports in mode 0.
- Connect DIP switches connected to the to input ports and LEDs to the output ports .
- Read switch positions connected to port A and turn on the respective LEDs of port b. Read switch positions of port C_L and display the reading at port C_U

BSR (Bit Set/Reset) Mode

BSR control word

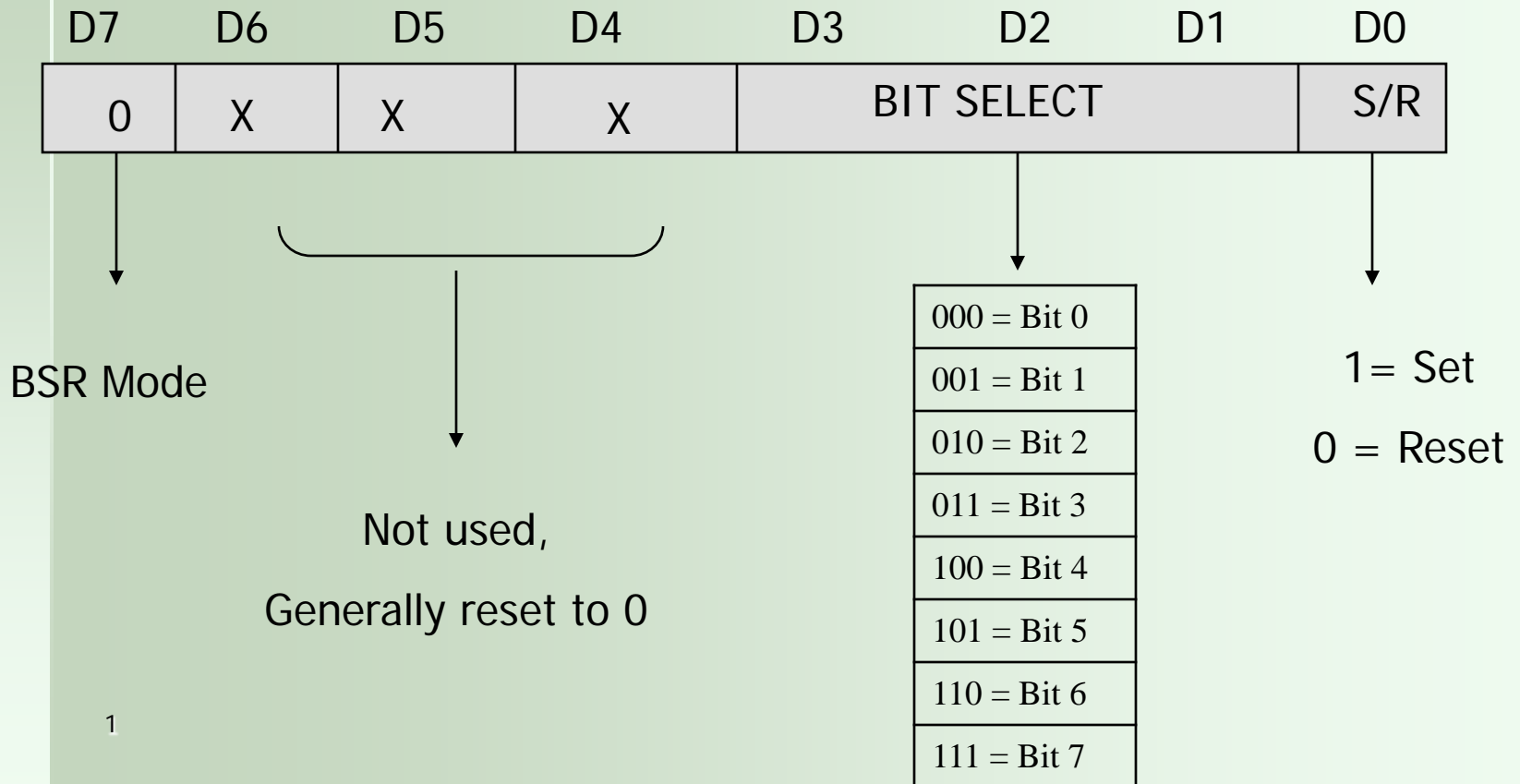

Problem 2)

- Write an ALP to set bits PC7 and PC 3 and reset them after 10 ms in BSR mode.

Mode 1: Input or Output with Handshake

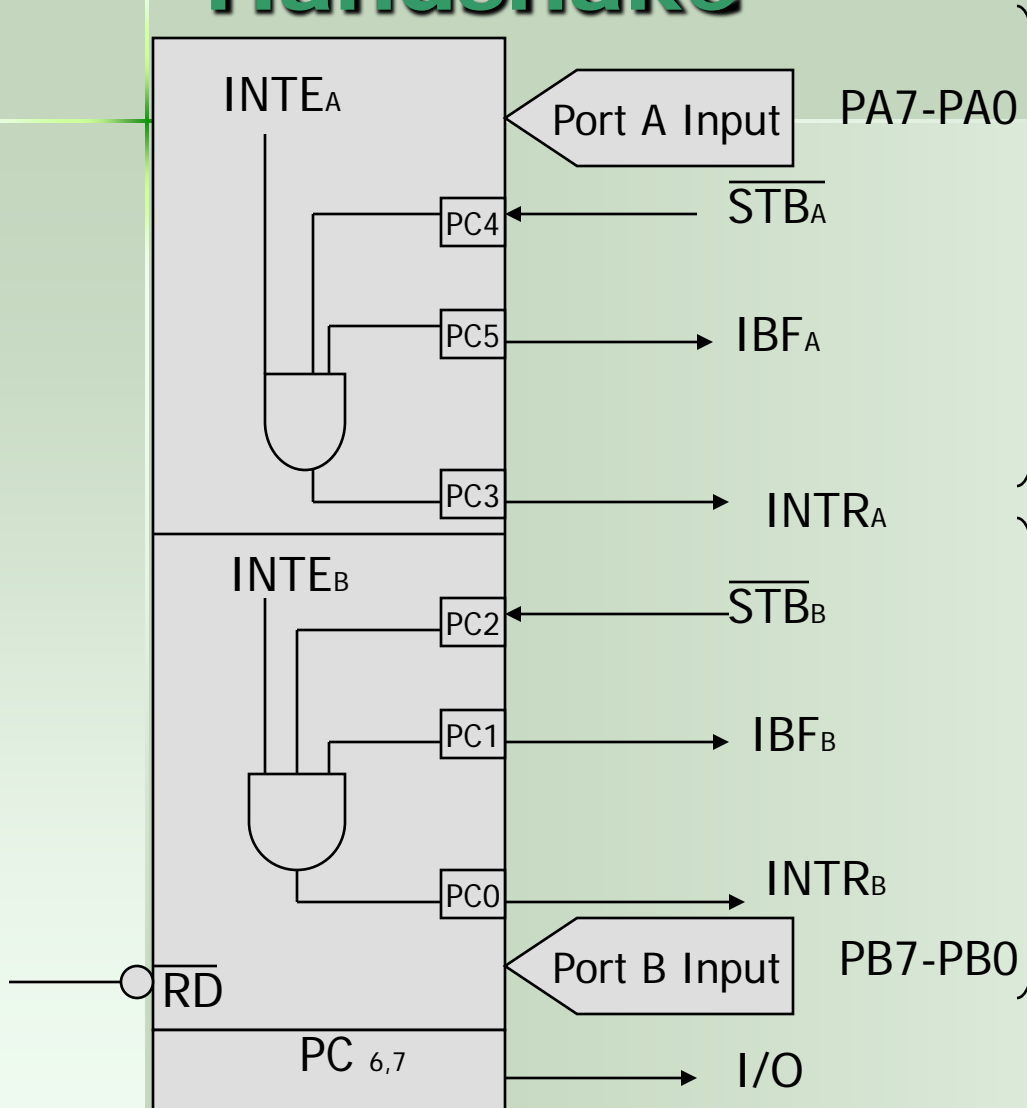

Port A with Handshake Signal

Port b with Handshake Signal

Port A & Port B as Input in Mode 1

Control word – mode 1 input

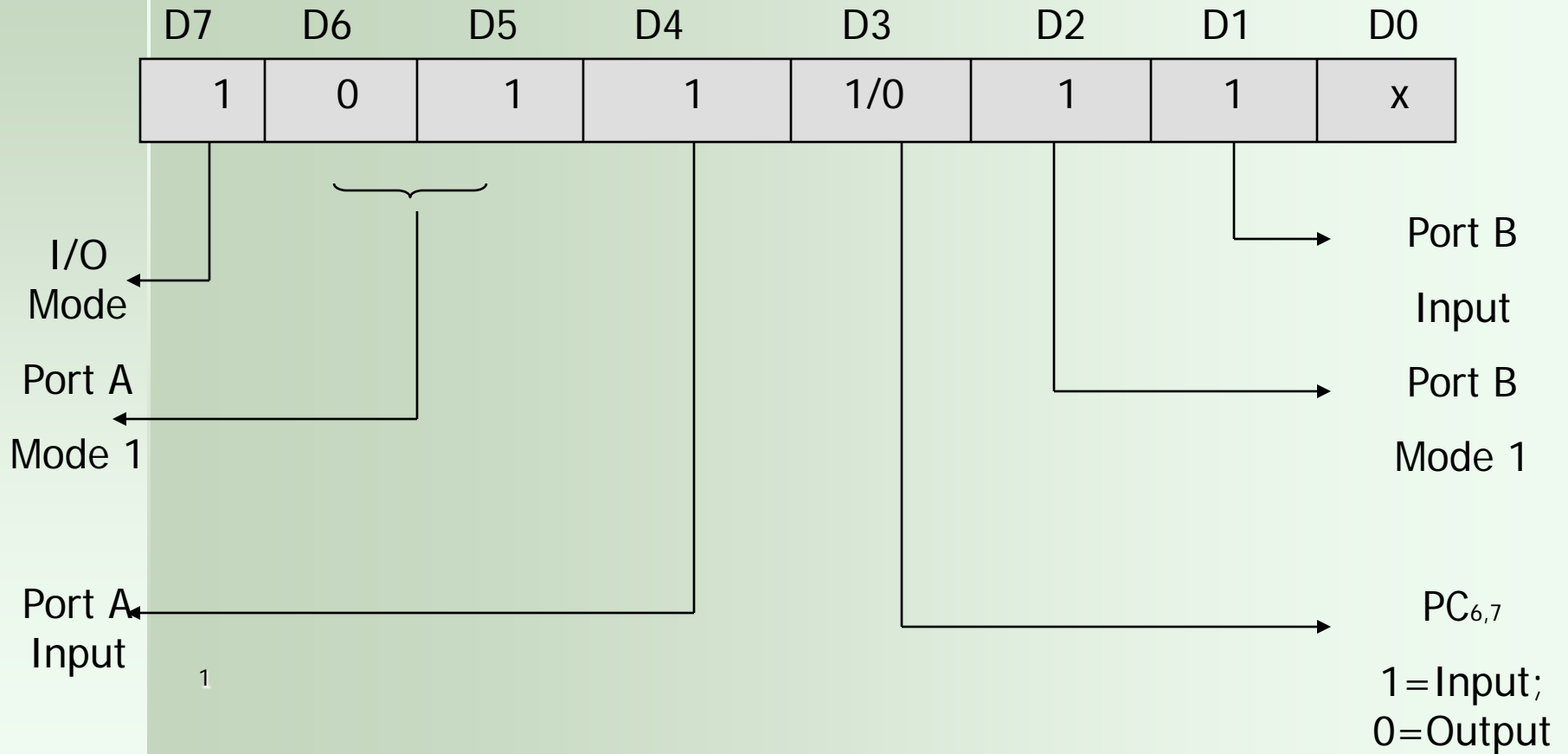

Status Word – Mode 1 input

D7	D6	D5	D4	D3	D2	D1	D0
I/O	I/O	IBF _A	INTE _A	INTR _A	INTE _B	IBF _B	INTR _B

$\overline{\text{STB}}$

IBF

INTR

$\overline{\text{RD}}$

Input from peripheral 1

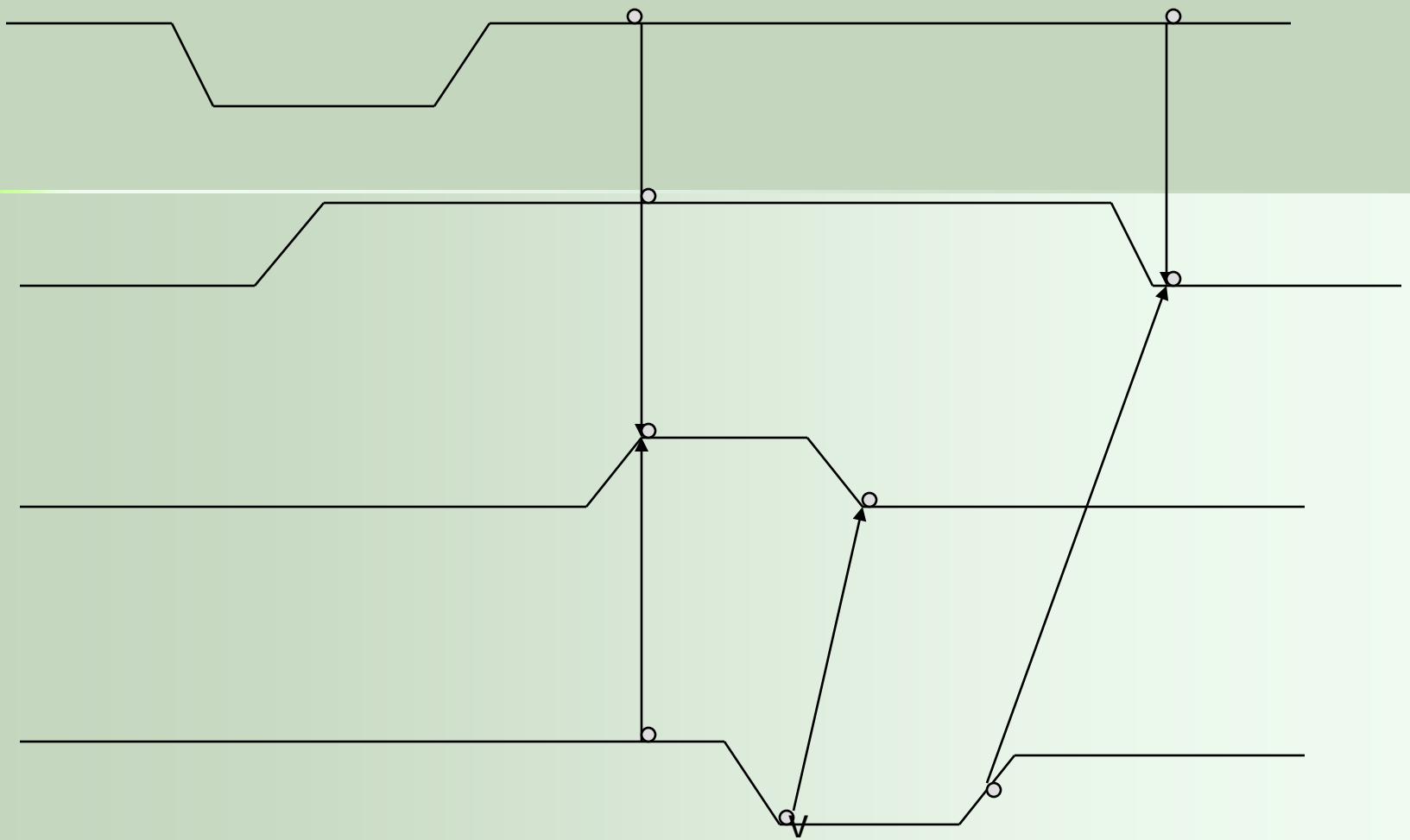

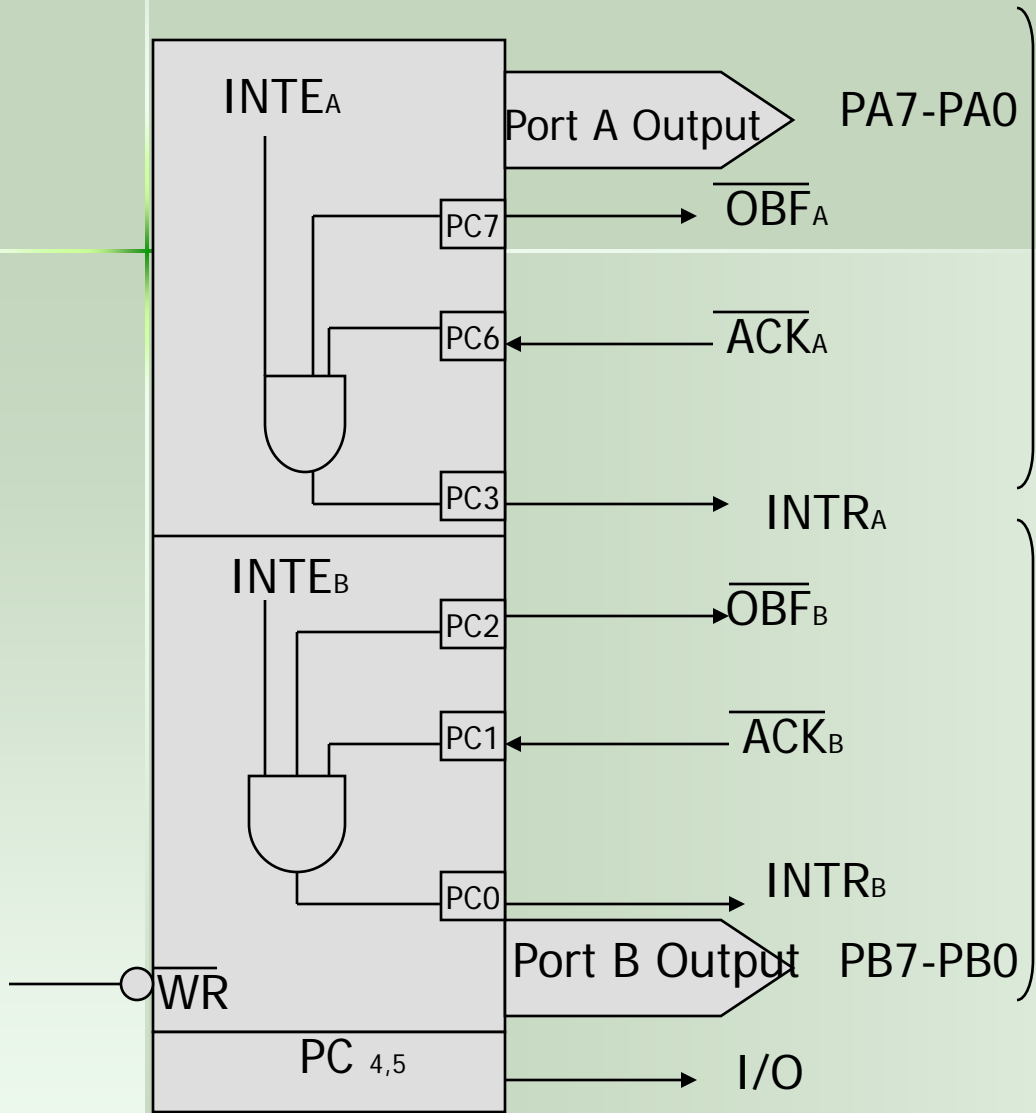

Port A with
Handshake
Signal

Port b with
Handshake
Signal

Port A & B as Output In Mode 1

Control word – mode 1 Output

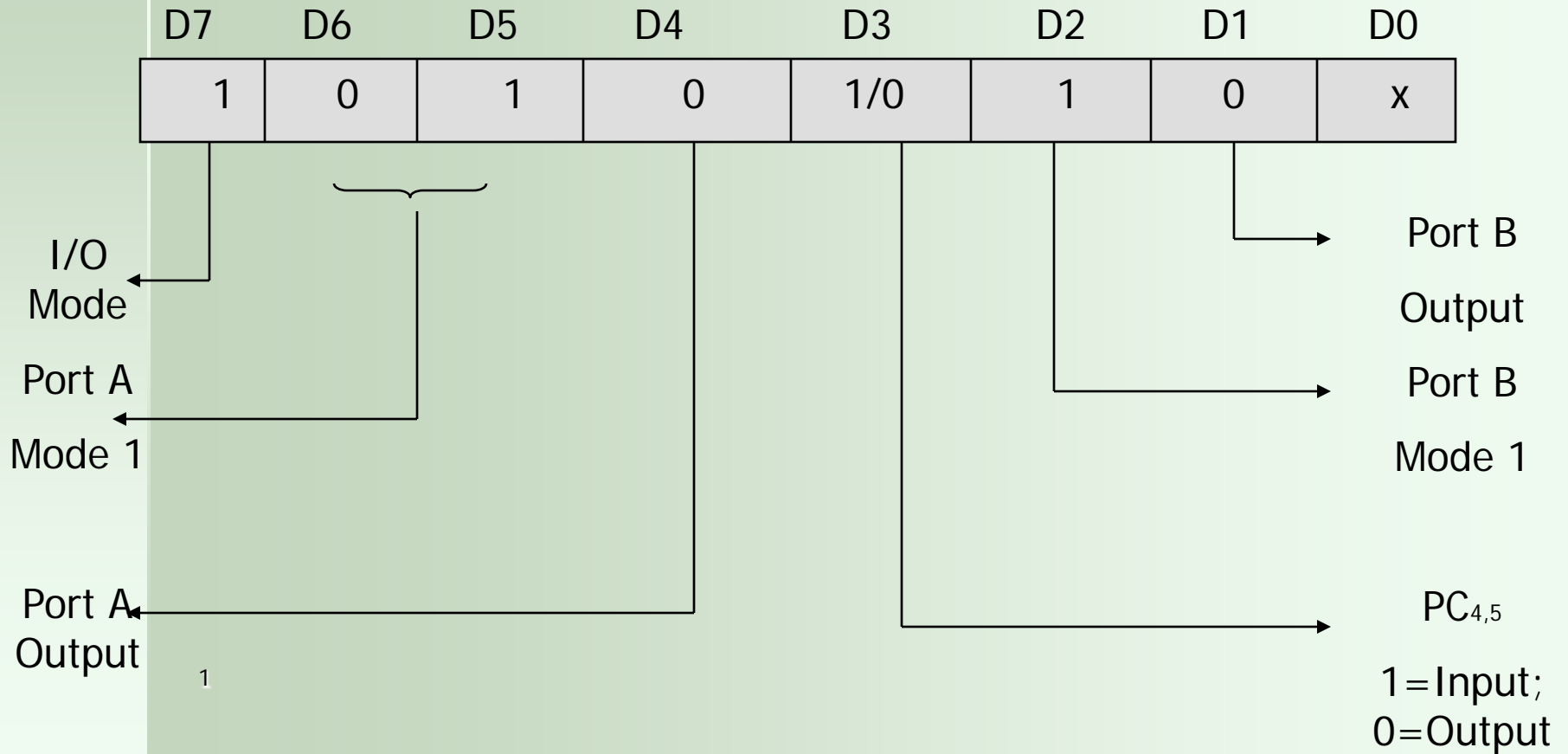

Status Word – Mode 1 Output

D7	D6	D5	D4	D3	D2	D1	D0
$\overline{\text{OBF}}_A$	INTE_a	I/O	I/O	INTR_A	INTE_B	$\overline{\text{OBF}}_B$	INTR_B

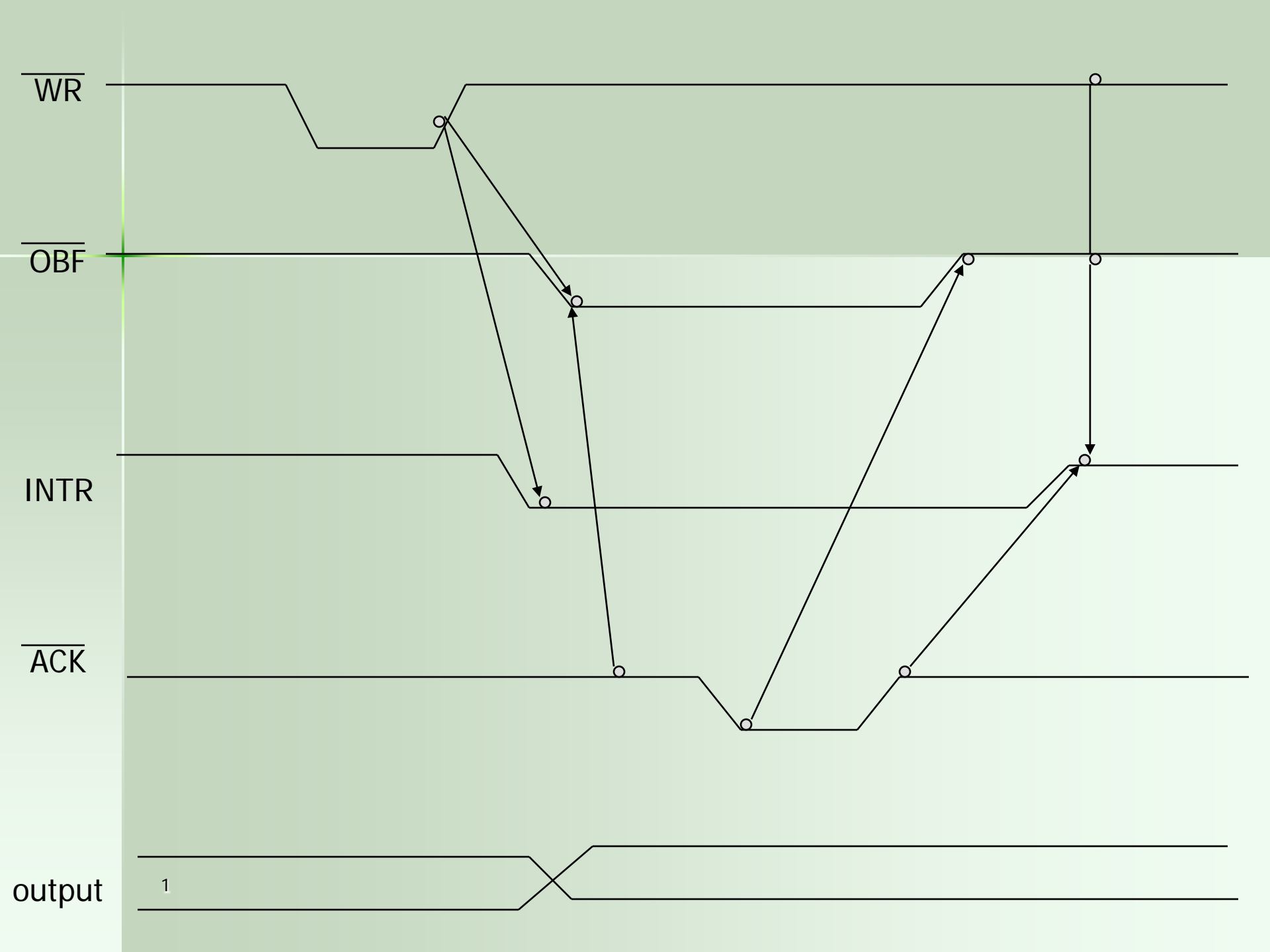

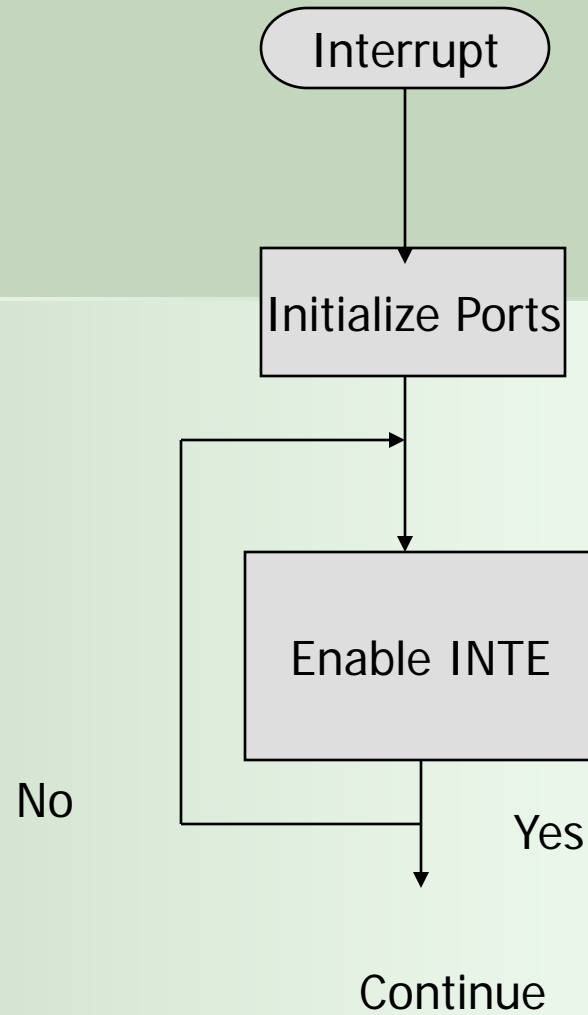
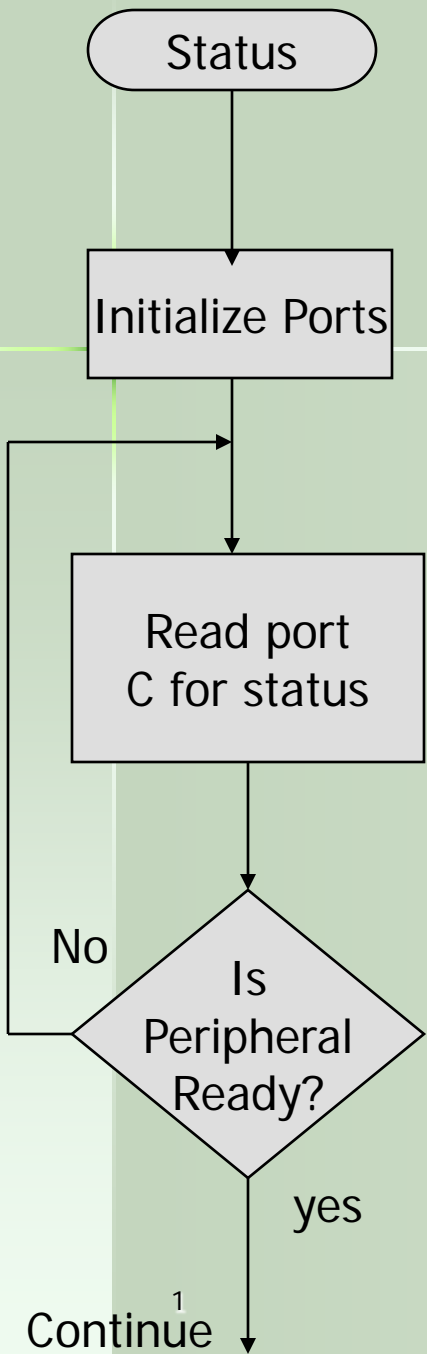

Problem 3)

- Initialize 8255A in mode 1 to configure Port A as an input port and Port B as an output port.
- Assuming that an A-to-d converter is connected with port A as an interrupt I/O and a printer is connected with port B as a status check I/O

8086 MICROPROCESSOR

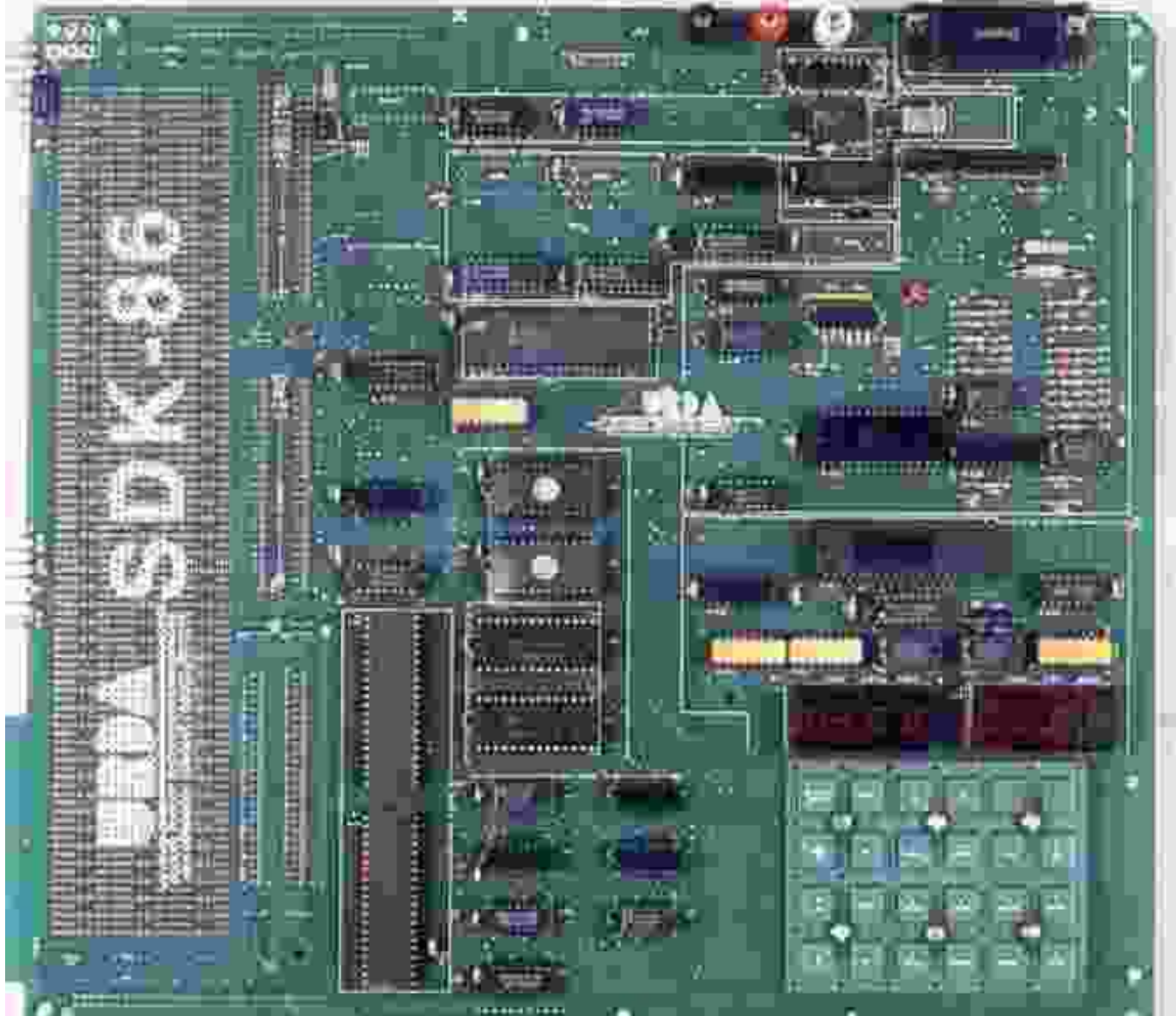

Pinouts

Common Signals		
Name	Function	Type
AD15-AD0	Address/Data Bus	Bidirectional, 3-State
A19/S6-A16/S3	Address/Status	Output, 3-State
$\overline{\text{BHE}}/\text{S7}$	Bus High Enable/Status	Output, 3-State
$\text{MN}/\overline{\text{MX}}$	Minimum/Maximum Mode Control	Input
$\overline{\text{RD}}$	Read Control	Output, 3-State
$\overline{\text{TEST}}$	Wait On Test Control	Input
READY	Wait State Control	Input
RESET	System Reset	Input
NMI	Non-Maskable Interrupt Request	Input
INTR	Interrupt Request	Input
CLK	System Clock +5V	Input
VCC	+5V	Input
GND	Ground	
Minimum Mode Signals (MN/MX = VCC)		
Name	Function	Type
HOLD	Hold Request	Input
HLDA	Hold Acknowledge	Output
$\overline{\text{WR}}$	Write Control	Output, 3-State
$\text{M}/\overline{\text{IO}}$	Memory/IO Control	Output, 3-State
$\text{DT}/\overline{\text{R}}$	Data Transmit/Receive	Output, 3-State
$\overline{\text{DEN}}$	Data Enable	Output, 3-State
ALE	Address Latch Enable	Output
$\overline{\text{INTA}}$	Interrupt Acknowledge	Output
Maximum Mode Signals (MN/MX = GND)		
Name	Function	Type
$\text{RQ}/\overline{\text{GT}}1, 0$	Request/Grant Bus Access Control	Bidirectional
$\overline{\text{LOCK}}$	Bus Priority Lock Control	Output, 3-State
S2-S0	Bus Cycle Status	Output, 3-State
QS1, QS0	Instruction Queue Status	Output

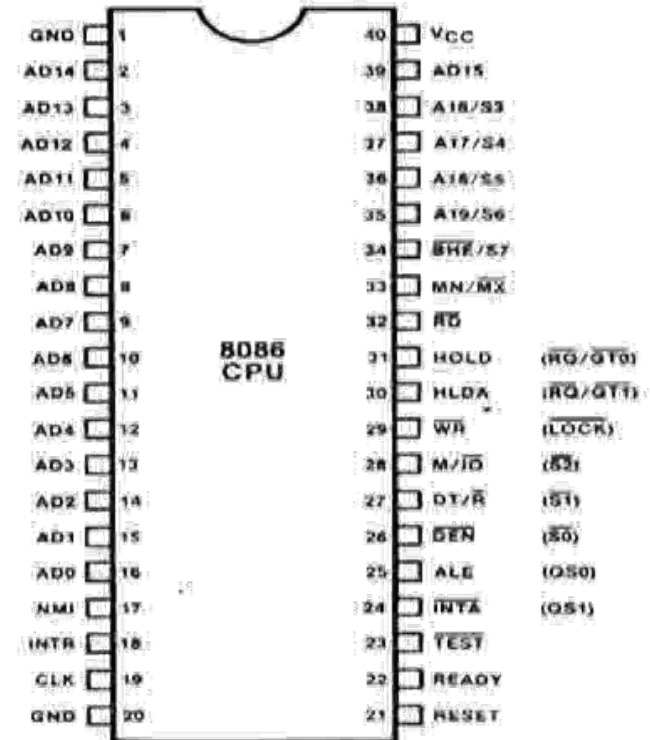

MAXIMUM MODE PIN FUNCTIONS (e.g., LOCK) ARE SHOWN IN PARENTHESES

8086 Pins

The 8086 comes in a 40 pin package which means that some pins have more than one use or are multiplexed. The packaging technology of time limited the number of pin that could be used.

In particular, the address lines 0 - 15 are multiplexed with data lines 0-15, address lines 16-19 are multiplexed with status lines. These pins are

AD0 - AD15, A16/S3 - A19/S6

The 8086 has one other pin that is multiplexed and this is BHE'/S7. BHE stands for Byte High Enable. This is an active low signal that is asserted when there is data on the upper half of the data bus.

The 8086 has two modes of operation that changes the function of some pins. The SDK-86 uses the 8086 in the minimum mode with the MN/MX' pin tied to 5 volts. This is a simple single processor mode. The IBM PC uses an 8088 in the maximum mode with the MN/MX'' pin tied to ground. This is the mode required for a coprocessor like the 8087.

8086 Pins

In the minimum mode the following pins are available.

- HOLD** When this pin is high, another master is requesting control of the local bus, e.g., a DMA controller.
- HLDA** HOLD Acknowledge: the 8086 signals that it is going to float the local bus.
- WR'** Write: the processor is performing a write memory or I/O operation.
- M/IO'** Memory or I/O operation.
- DT/R'** Data Transmit or Receive.
- DEN'** Data Enable: data is on the multiplexed address/data pins.
- ALE** Address Latch Enable: the address is on the address/data pins. This signal is used to capture the address in latches to establish the address bus.
- INTA'** Interrupt acknowledge: acknowledges external interrupt requests.

8086 Pins

The following pins are available in both minimum and maximum modes.

VCC + 5 volt power supply pin.

GND Ground

RD' **READ:** the processor is performing a read memory or I/O operation.

READY Acknowledgement from wait-state logic that the data transfer will be completed.

RESET Stops processor and restarts execution from FFFF:0. Must be high for 4 clocks. CS = 0FFFFH, IP = DS = SS = ES = Flags = 0000H, no other registers are affected.

TEST' The WAIT instruction waits for this pin to go low. Used with 8087.

NMI Non Maskable Interrupt: transition from low to high causes an interrupt. Used for emergencies such as power failure.

INTR Interrupt request: masked by the IF bit in FLAG register.

CLK Clock: 33% duty cycle, i.e., high 1/3 the time.

8086 Features

- **16-bit Arithmetic Logic Unit**
- **16-bit data bus (8088 has 8-bit data bus)**
- **20-bit address bus - $2^{20} = 1,048,576 = 1$ meg**

The address refers to a byte in memory. In the 8088, these bytes come in on the 8-bit data bus. In the 8086, bytes at even addresses come in on the low half of the data bus (bits 0-7) and bytes at odd addresses come in on the upper half of the data bus (bits 8-15).

The 8086 can read a 16-bit word at an even address in one operation and at an odd address in two operations. The 8088 needs two operations in either case.

The least significant byte of a word on an 8086 family microprocessor is at the lower address.

8086 Architecture

- The 8086 has two parts, the **Bus Interface Unit (BIU)** and the **Execution Unit (EU)**.
- The BIU fetches instructions, reads and writes data, and computes the 20-bit address.
- The EU decodes and executes the instructions using the 16-bit ALU.
- The BIU contains the following registers:
 - IP - the Instruction Pointer
 - CS - the Code Segment Register
 - DS - the Data Segment Register
 - SS - the Stack Segment Register
 - ES - the Extra Segment Register

The BIU fetches instructions using the CS and IP, written CS:IP, to construct the 20-bit address. Data is fetched using a segment register (usually the DS) and an effective address (EA) computed by the EU depending on the addressing mode.

8086 Block Diagram

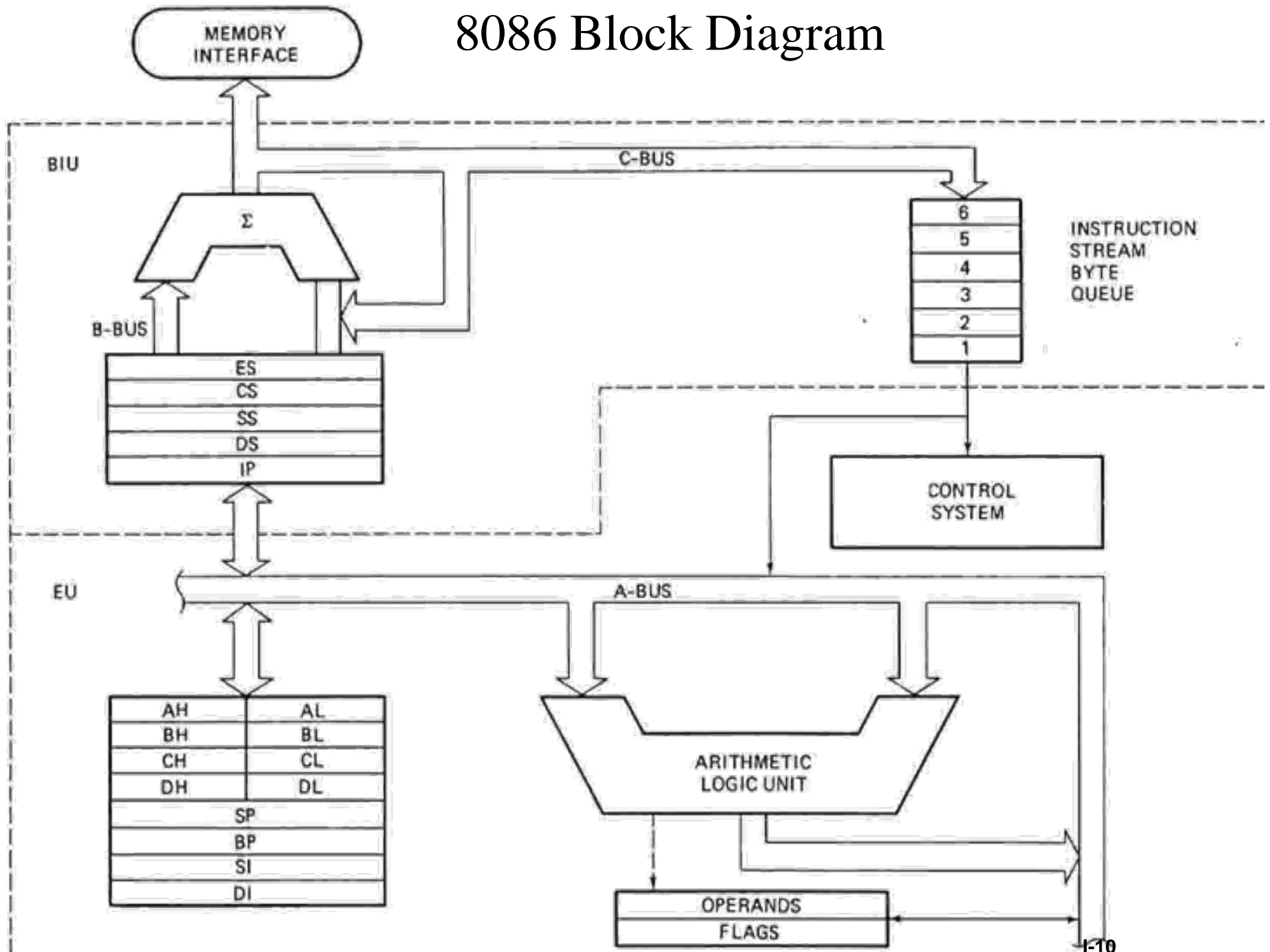

8086 Architecture

The EU contains the following 16-bit registers:

AX - the Accumulator

BX - the Base Register

CX - the Count Register

DX - the Data Register

SP - the Stack Pointer \ defaults to stack segment

BP - the Base Pointer /

SI - the Source Index Register

DI - the Destination Register

These are referred to as general-purpose registers, although, as seen by their names, they often have a special-purpose use for some instructions.

The AX, BX, CX, and DX registers can be considered as two 8-bit registers, a High byte and a Low byte. This allows byte operations and compatibility with the previous generation of 8-bit processors, the 8080 and 8085. 8085 source code could be translated in 8086 code and assembled. The 8-bit registers are:

AX --> AH,AL

BX --> BH,BL

CX --> CH,CL

DX --> DH,DL

Flag Register

- ❑ Flag register contains information reflecting the current status of a microprocessor. It also contains information which controls the operation of the microprocessor.

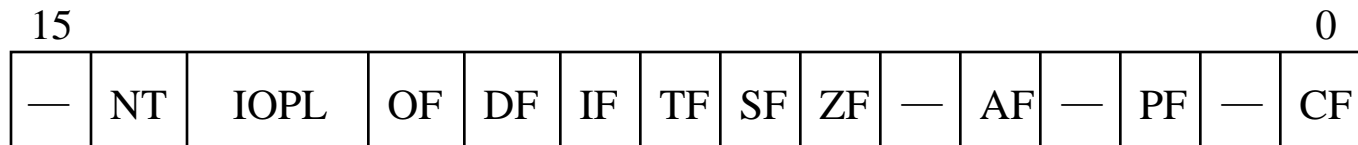

➤ Control Flags

IF: Interrupt enable flag
DF: Direction flag
TF: Trap flag

➤ Status Flags

CF: Carry flag
PF: Parity flag
AF: Auxiliary carry flag
ZF: Zero flag
SF: Sign flag
OF: Overflow flag
NT: Nested task flag
IOPL: Input/output privilege level

Flags Commonly Tested During the Execution of Instructions

- There are five flag bits that are commonly tested during the execution of instructions
 - Sign Flag (Bit 7), SF: 0 for positive number and 1 for negative number
 - Zero Flag (Bit 6), ZF: If the ALU output is 0, this bit is set (1); otherwise, it is 0
 - Carry Flag (Bit 0), CF: It contains the carry generated during the execution
 - Auxiliary Carry, AF: Depending on the width of ALU inputs, this flag bit contains the carry generated at bit 3 (or, 7, 15) of the 8088 ALU
(Bit 4)
 - Parity Flag (bit2), PF: It is set (1) if the output of the ALU has even number of ones; otherwise it is zero

Direction Flag

□ Direction Flag (DF) is used to control the way SI and DI are adjusted during the execution of a string instruction

— DF=0, SI and DI will auto-increment during the execution; otherwise, SI and DI auto-decrement

— Instruction to set DF: **STD**; Instruction to clear DF: **CLD**

— Example:

```
CLD
MOV CX, 5
REP MOVSB
```

At the beginning of execution,
DS=0510H and SI=0000H

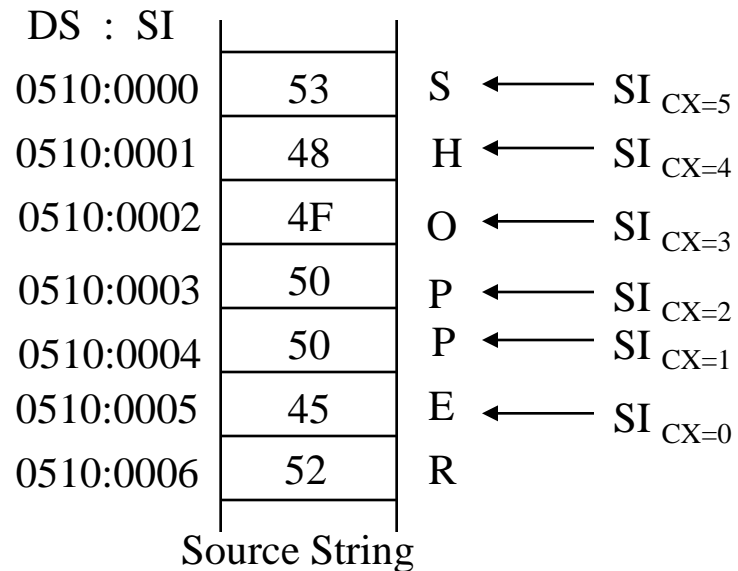

8086 Programmer's Model

BIU registers
(20 bit adder)

ES
CS
SS
DS
IP

Extra Segment
Code Segment
Stack Segment
Data Segment
Instruction Pointer

AX
BX
CX
DX

AH	AL
BH	BL
CH	CL
DH	DL
SP	
BP	
SI	
DI	
FLAGS	

Accumulator
Base Register
Count Register
Data Register
Stack Pointer
Base Pointer
Source Index Register
Destination Index Register

EU registers
16 bit arithmetic

Memory Address Calculation

- ❑ Segment addresses must be stored in segment registers
- ❑ Offset is derived from the combination of pointer registers, the Instruction Pointer (IP), and immediate values
- ❑ Examples

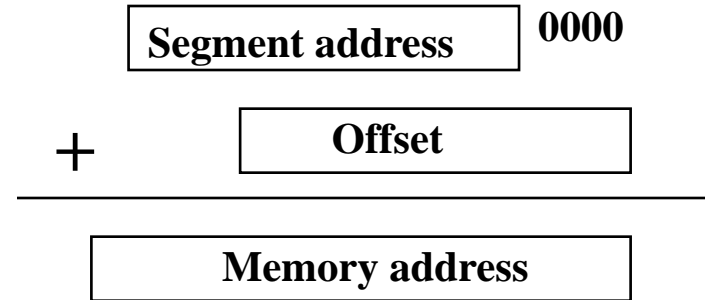

CS	3	4	8	A	0
IP +		4	2	1	4
Instruction address	3	8	A	B	4

SS	5	0	0	0	0
SP +		F	F	E	0
Stack address	5	F	F	E	0

DS	1	2	3	4	0
DI +		0	0	2	2
Data address	1	2	3	6	2

Segments

Segment Starting address is segment register value shifted 4 places to the left.

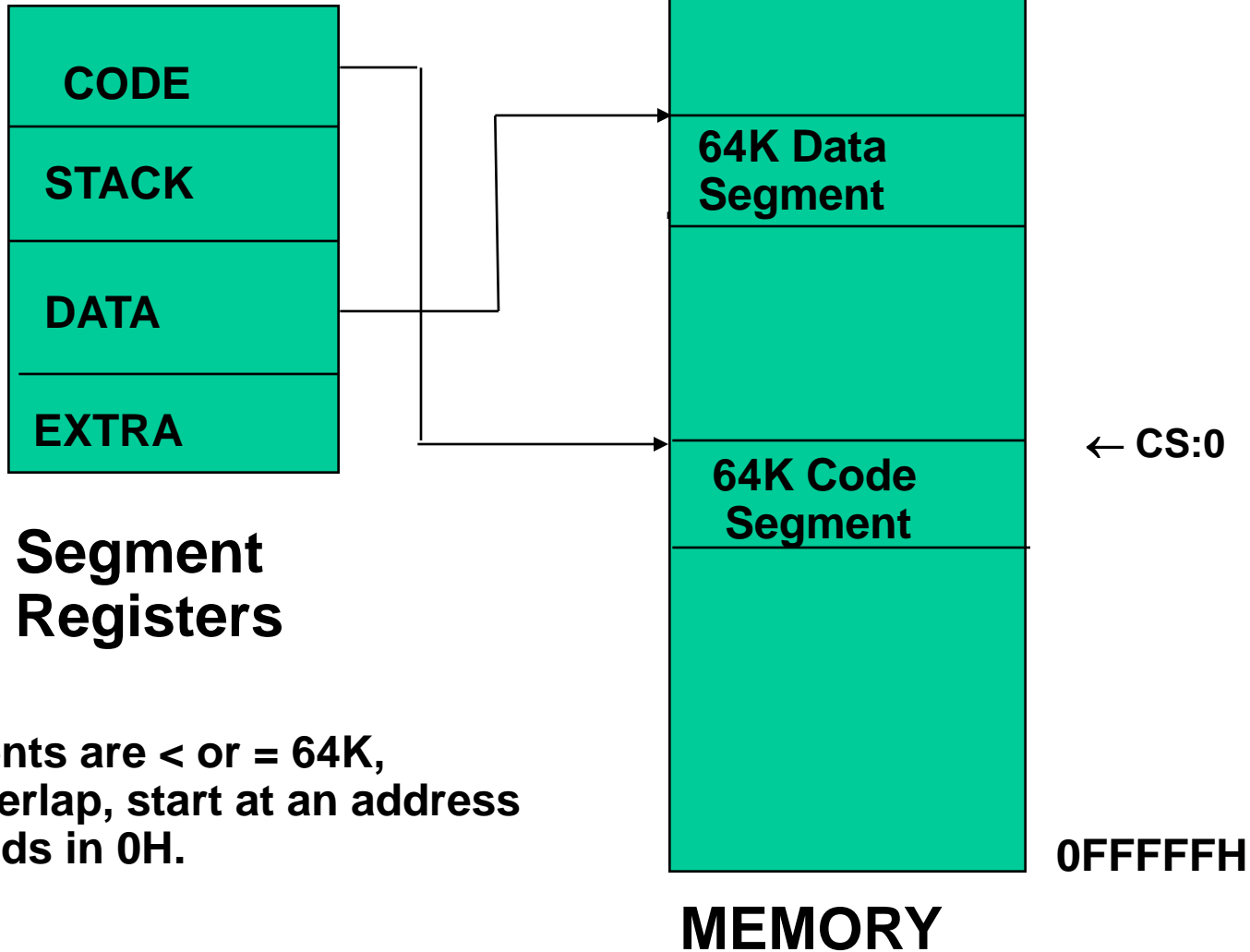

Segments are $<$ or $=$ 64K, can overlap, start at an address that ends in 0H.

8086 Memory Terminology

Memory Segments

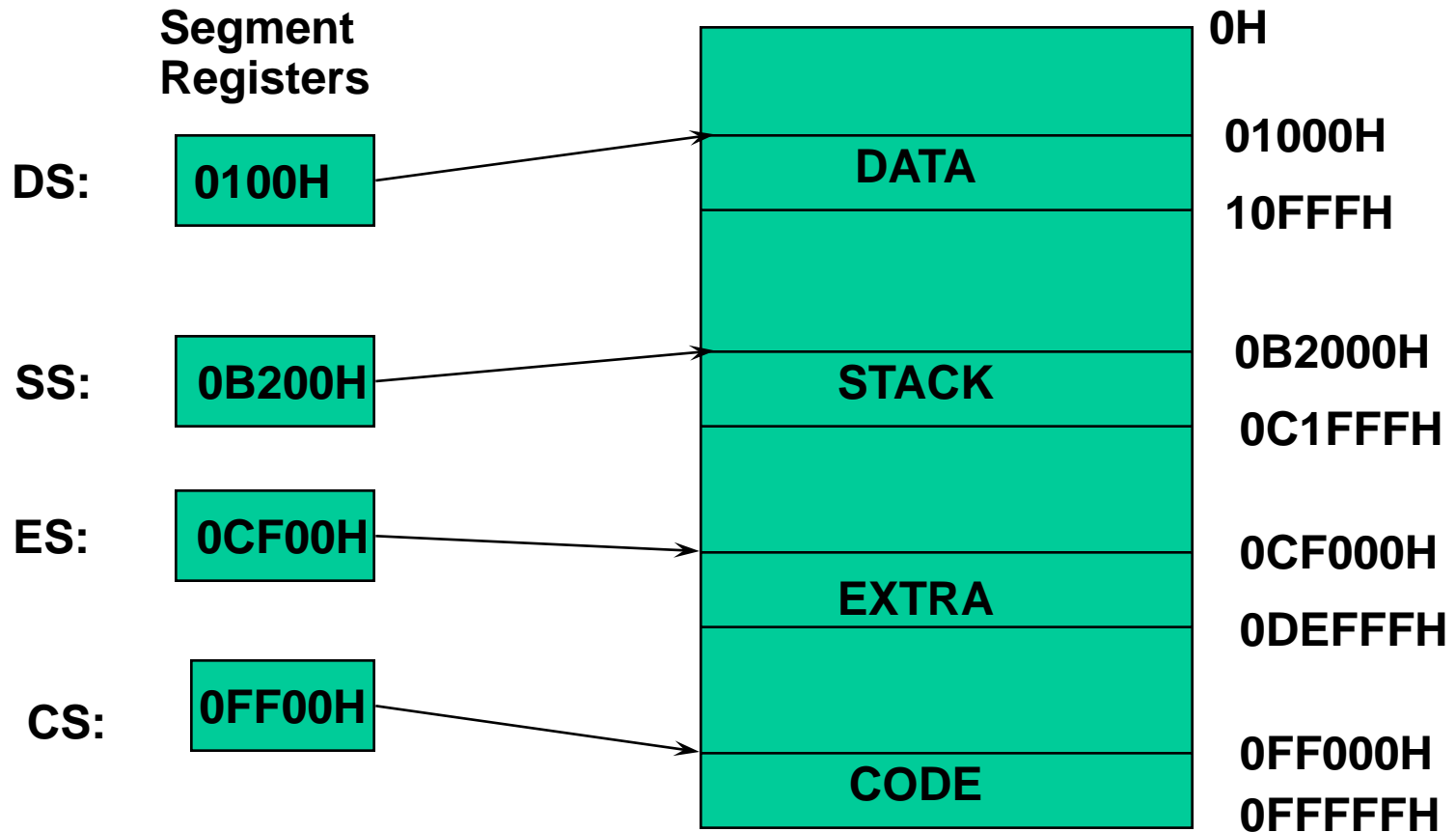

Segments are $\leq 64K$ and can overlap.

Note that the Code segment is $< 64K$ since 0FFFFFFH is the highest address.

The Code Segment

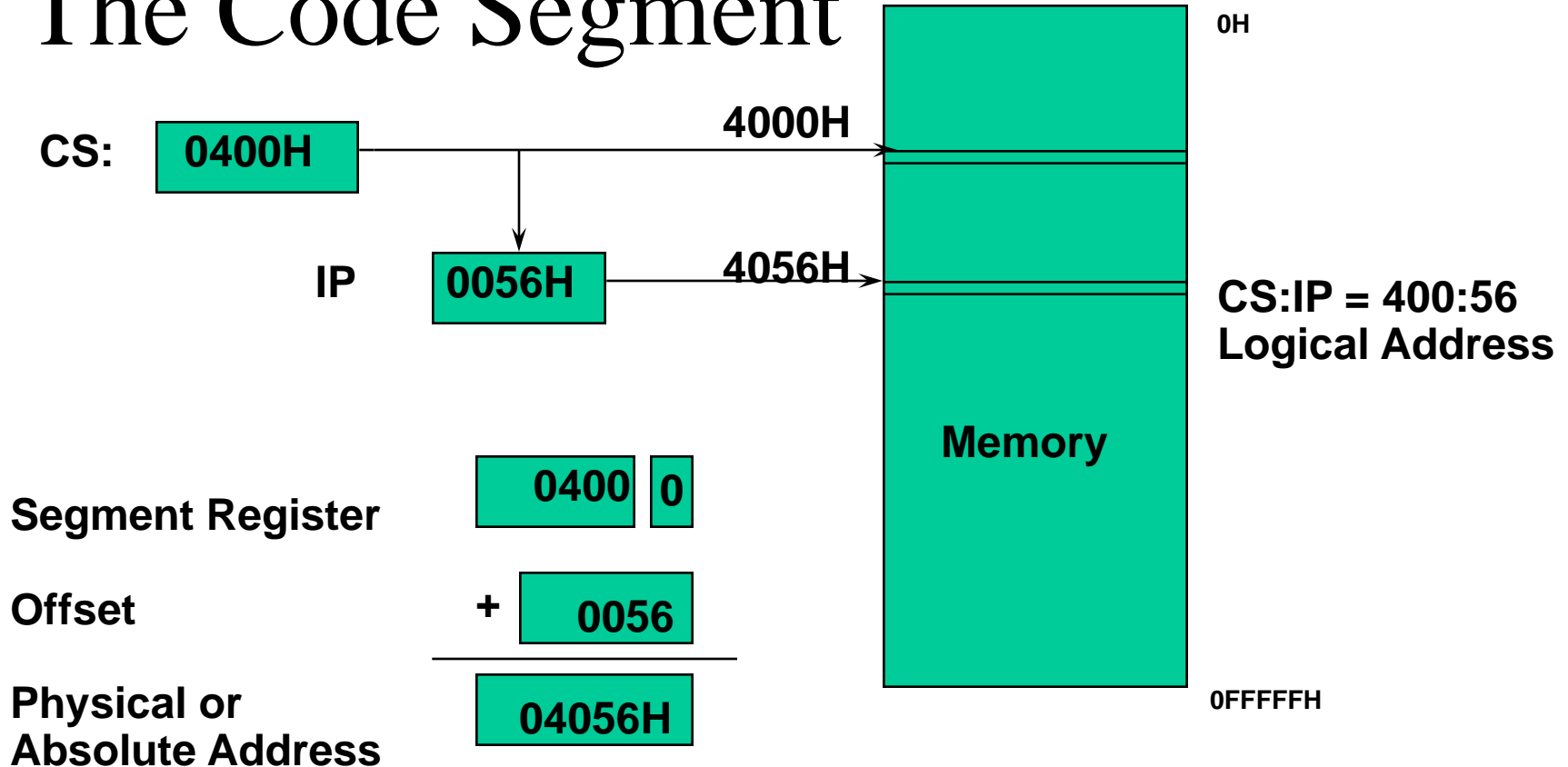

The offset is the distance in bytes from the start of the segment. The offset is given by the IP for the Code Segment. Instructions are always fetched with using the CS register.

The physical address is also called the absolute address.

The Stack Segment

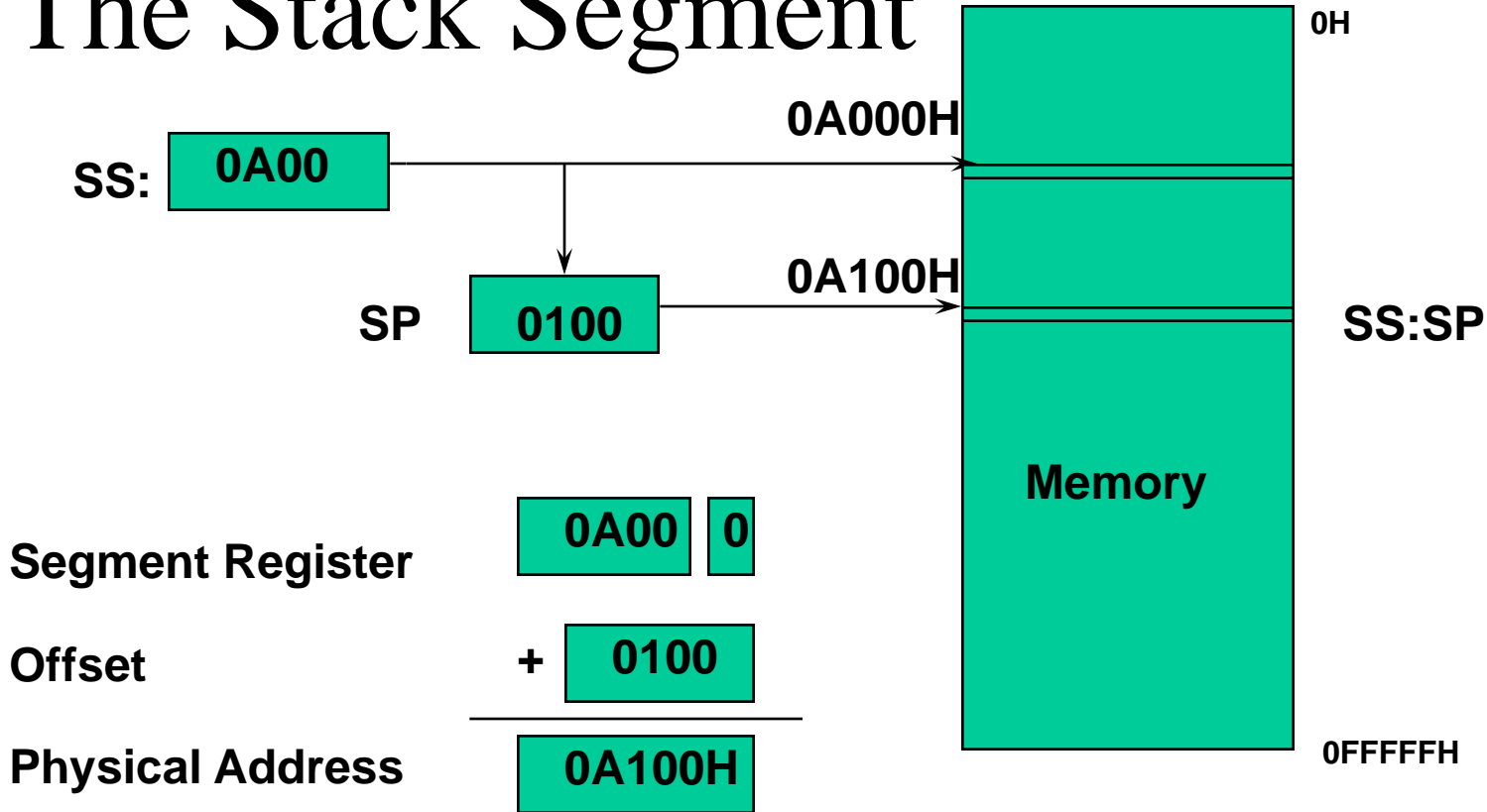

The offset is given by the SP register.
The stack is always referenced with respect to the stack segment register.
The stack grows toward decreasing memory locations.
The SP points to the last or top item on the stack.

PUSH - pre-decrement the SP
POP - post-increment the SP

The Data Segment

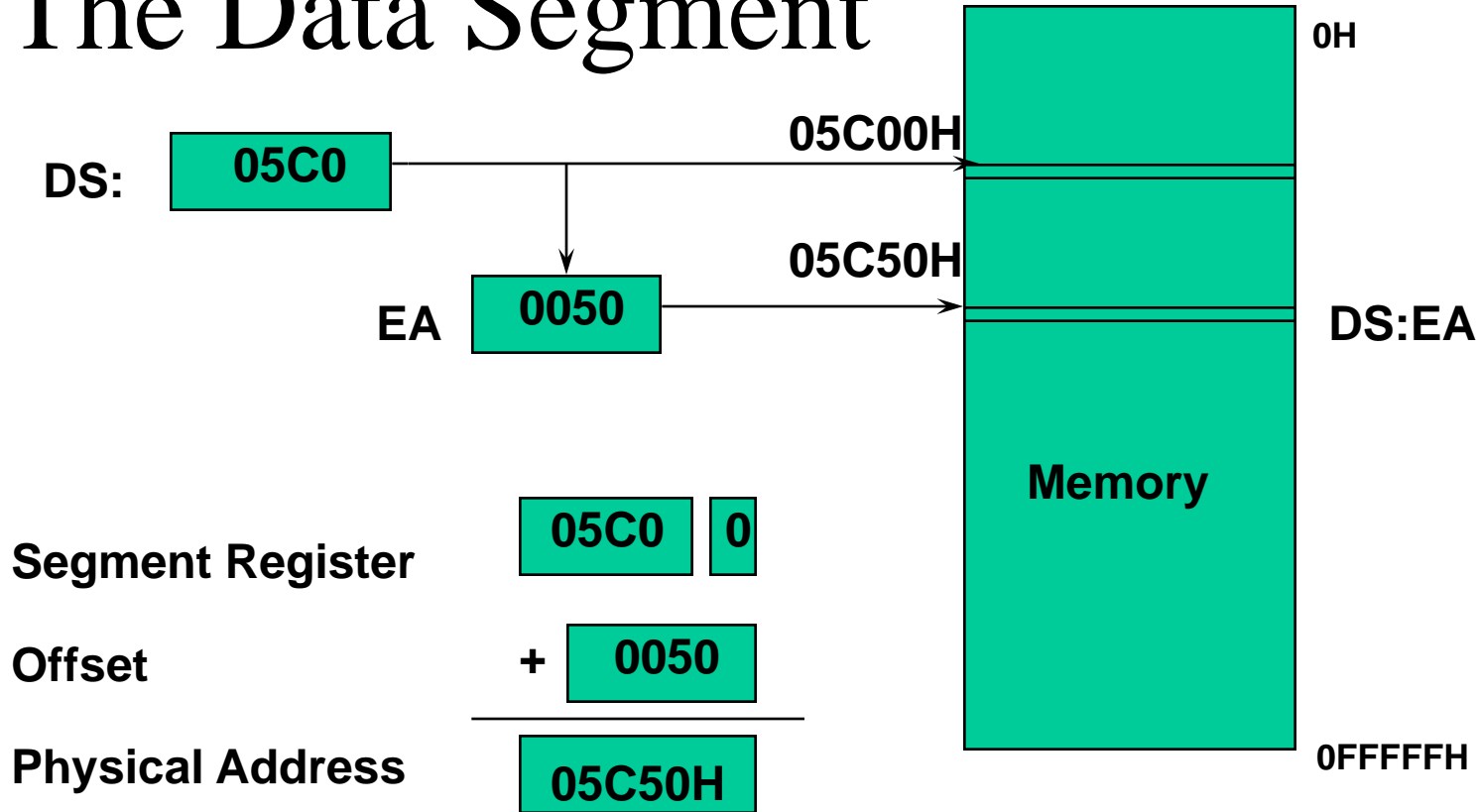

Data is usually fetched with respect to the DS register.
The effective address (EA) is the offset.
The EA depends on the addressing mode.

8086 memory Organization

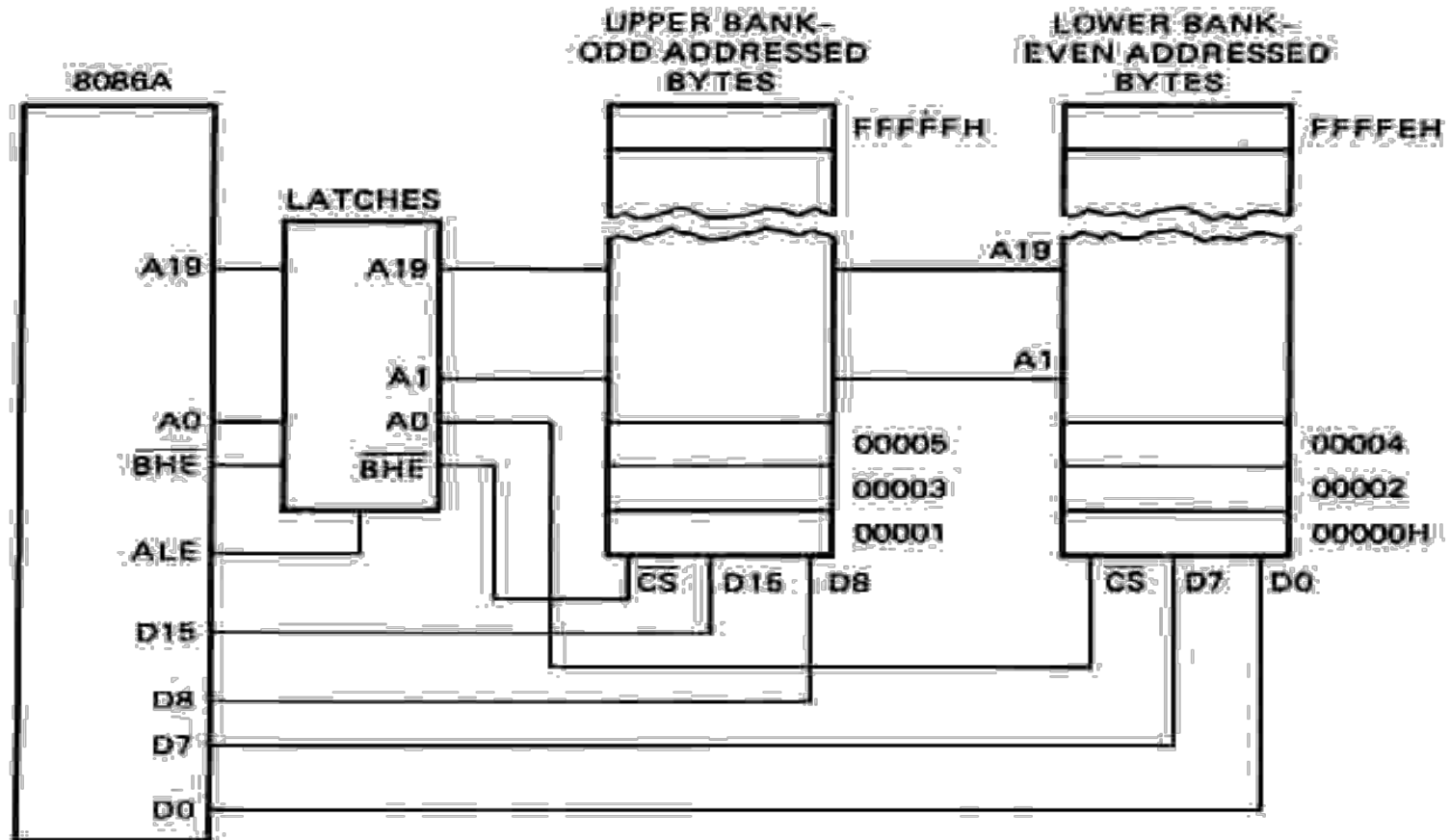

(a)

ADDRESS	DATA TYPE	BHE	A0	BUS CYCLES	DATA LINES USED
0000	BYTE	1	0	ONE	D0-D7
0000	WORD	0	0	ONE	D0-D15
0001	BYTE	0	1	ONE	D8-D15
0001	WORD	0	1	FIRST	D0-D8
		1	0	SECOND	D8-D15

Even addresses are on the low half of the data bus (D0-D7).

Odd addresses are on the upper half of the data bus (D8-D15).

A0 = 0 when data is on the low half of the data bus.

BHE' = 0 when data is on the upper half of the data bus.

MAX and MIN Modes

- In minmode, the 9 signals correspond to **control signals** that are needed to operate memory and I/O devices connected to the 8088.
- In maxmode, the 9 signals change their functions; the 8088 now requires the use of the **8288 bus controller** to generate memory and I/O read/write signals.

Why MIN and MAX modes?

- Minmode signals can be directly decoded by memory and I/O circuits, resulting in a system with minimal hardware requirements.
- Maxmode systems are more complicated, but obtain the new signals that allow for bus grants (e.g. DMA), and the use of an 8087 coprocessor.

The 9 pins (min)

- **ALE: address latch enable (AD0 – AD7)
- **DEN: data enable (connect/disc. buffer)
- **WR: write (writing indication)
- *HOLD
- *HDLA: hold acknowledge
- *INTA: interrupt acknowledge
- IO/M: memory access or I/O access
- DT/R: data transmit / receive (direction)
- SSO: status

The 9 pins (max)

- S0, S1, S2: status
- *RQ/GT0, RQ/GT1: request/grant
- *LOCK: locking the control of the sys. bus
- *QS1, QS0: queue status (tracking of internal instruction queue).
- HIGH

Instruction Types

- Data transfer instructions**
- String instructions**
- Arithmetic instructions**
- Bit manipulation instructions**
- Loop and jump instructions**
- Subroutine and interrupt instructions**
- Processor control instructions**

Addressing Modes

<i>Addressing Modes</i>	<i>Examples</i>
<input type="checkbox"/> Immediate addressing	MOV AL, 12H
<input type="checkbox"/> Register addressing	MOV AL, BL
<input type="checkbox"/> Direct addressing	MOV [500H], AL
<input type="checkbox"/> Register Indirect addressing	MOV DL, [SI]
<input type="checkbox"/> Based addressing	MOV AX, [BX+4]
<input type="checkbox"/> Indexed addressing	MOV [DI-8], BL
<input type="checkbox"/> Based indexed addressing	MOV [BP+SI], AH
<input type="checkbox"/> Based indexed with displacement addressing	MOV CL, [BX+DI+2]

Exceptions

- String addressing
- Port addressing (e.g. IN AL, 79H)

Data Transfer Instructions

❑ *MOV Destination, Source*

- Move data from source to destination; *e.g.* **MOV [DI+100H], AH**
- It does not modify flags

- For 80x86 family, directly moving data from one memory location to another memory location is not allowed

MOV [SI], [5000H]



- When the size of data is not clear, assembler directives are used

MOV [SI], 0



- **BYTE PTR**
- **WORD PTR**
- **DWORD PTR**

MOV BYTE PTR [SI], 12H
MOV WORD PTR [SI], 12H
MOV DWORD PTR [SI], 12H

- You can not move an immediate data to segment register by MOV

MOV DS, 1234H



Instructions for Stack Operations

❑ What is a Stack ?

- A stack is a collection of memory locations. It always follows the rule of last-in-first-out
- Generally, SS and SP are used to trace where is the latest data written into stack

❑ PUSH *Source*

- Push data (**word**) onto stack
- It does not modify flags
- For Example: PUSH AX (assume ax=1234H, SS=1000H, SP=2000H before PUSH AX)

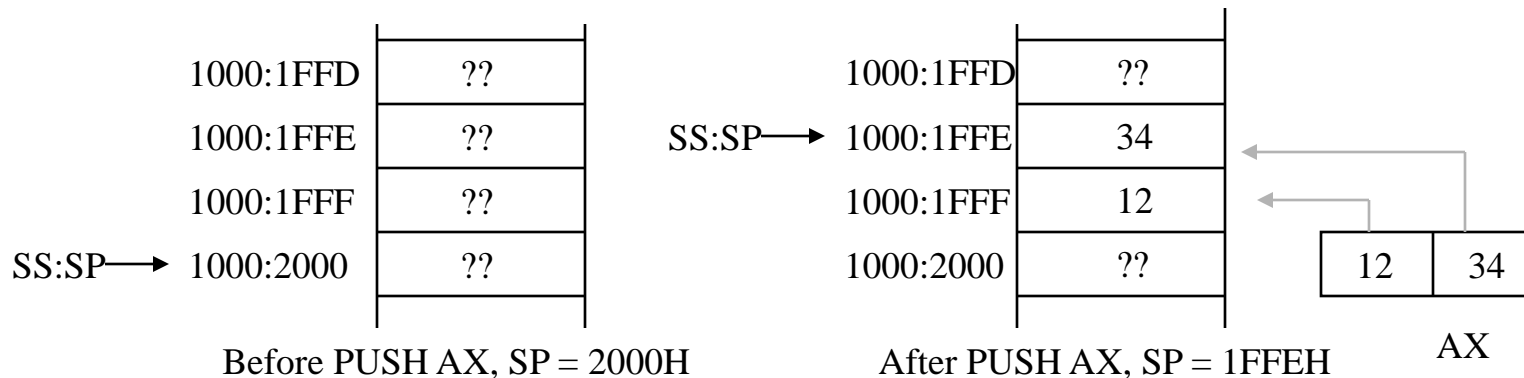

- Decrementing the stack pointer during a push is a standard way of implementing stacks in hardware

Instructions for Stack Operations

❑ PUSHF

- Push the values of the flag register onto stack
- It does not modify flags

❑ POP *Destination*

- Pop word off stack
- It does not modify flags
- For example: **POP AX**

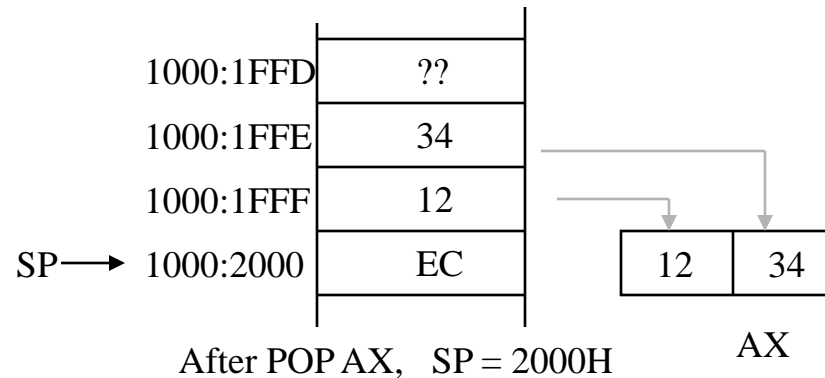
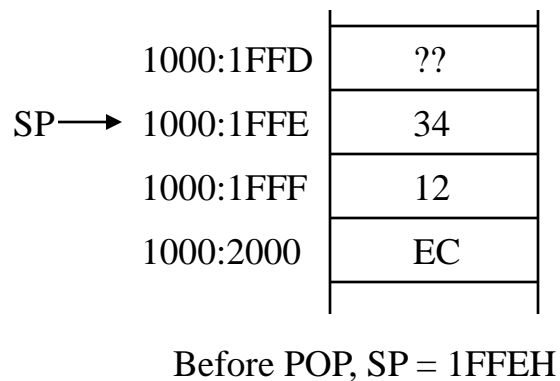

❑ POPF

- Pop word from the stack to the flag register
- It modifies all flags

Data Transfer Instructions

❑ SAHF

- Store data in AH to the low 8 bits of the flag register
- It modifies flags: AF, CF, PF, SF, ZF

❑ LAHF

- Copies bits 0-7 of the flags register into AH
- It does not modify flags

❑ LDS *Destination Source*

- Load 4-byte data (pointer) in memory to two 16-bit registers
- Source operand gives the memory location
- The first two bytes are copied to the register specified in the destination operand; the second two bytes are copied to register DS
- It does not modify flags

❑ LES *Destination Source*

- It is identical to LDS except that the second two bytes are copied to ES
- It does not modify flags

Data Transfer Instructions

❑ *LEA Destination Source*

- Transfers the offset address of source (must be a memory location) to the destination register
- It does not modify flags

❑ *XCHG Destination Source*

- It exchanges the content of destination and source
- One operand must be a microprocessor register, the other one can be a register or a memory location
- It does not modify flags

❑ *XLAT*

- Replace the data in AL with a data in a user defined look-up table
- BX stores the beginning address of the table
- At the beginning of the execution, the number in AL is used as the index of the look-up table
- It does not modify flags

String Instructions

- ❑ String is a collection of bytes, words, or long-words that can be up to 64KB in length
- ❑ String instructions can have at most two operands. One is referred to as source string and the other one is called destination string
 - Source string must locate in Data Segment and SI register points to the current element of the source string
 - Destination string must locate in Extra Segment and DI register points to the current element of the destination string

DS : SI		
0510:0000	53	S
0510:0001	48	H
0510:0002	4F	O
0510:0003	50	P
0510:0004	50	P
0510:0005	45	E
0510:0006	52	R

Source String

ES : DI		
02A8:2000	53	S
02A8:2001	48	H
02A8:2002	4F	O
02A8:2003	50	P
02A8:2004	50	P
02A8:2005	49	I
02A8:2006	4E	N

Destination String

Repeat Prefix Instructions

□ REP *String Instruction*

— The prefix instruction makes the microprocessor repeatedly execute the string instruction until CX decrements to 0 (During the execution, CX is decreased by one when the string instruction is executed one time).

— For Example:

```
MOV CX, 5  
REP MOVSB
```

By the above two instructions, the microprocessor will execute MOVSB 5 times.

— Execution flow of REP MOVSB::

```
While (CX!=0)  
{  
  CX = CX -1;  
  MOVSB;  
}
```

OR

```
Check_CX: If CX!=0 Then  
  CX = CX -1;  
  MOVSB;  
  goto Check_CX;  
end if
```

String Instructions

❑ MOVSB (MOVSW)

- Move byte (word) at memory location DS:SI to memory location ES:DI and update SI and DI according to DF and the width of the data being transferred
- It does not modify flags
- Example:

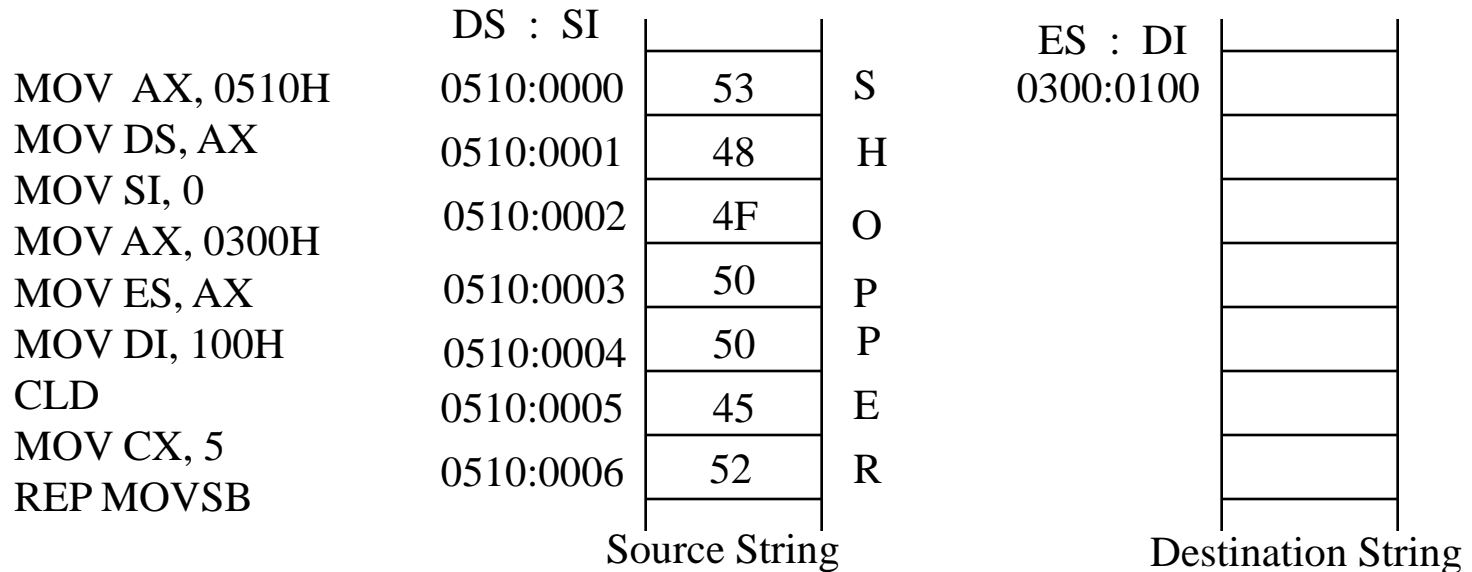

String Instructions

❑ CMPSB (CMPSW)

- Compare bytes (words) at memory locations DS:SI and ES:DI;
update SI and DI according to DF and the width of the data being compared
- It modifies flags
- Example:

Assume: ES = 02A8H
DI = 2000H
DS = 0510H
SI = 0000H

CLD
MOV CX, 9
REPZ CMPSB

What's the values of CX after
The execution?

DS : SI		
0510:0000	53	S
0510:0001	48	H
0510:0002	4F	O
0510:0003	50	P
0510:0004	50	P
0510:0005	45	E
0510:0006	52	R

Source String

ES : DI		
02A8:2000	53	S
02A8:2001	48	H
02A8:2002	4F	O
02A8:2003	50	P
02A8:2004	50	P
02A8:2005	49	I
02A8:2006	4E	N

Destination String

String Instructions

❑ SCASB (SCASW)

- Move byte (word) in AL (AX) and at memory location ES:DI;
update DI according to DF and the width of the data being compared
- It modifies flags

❑ LODSB (LODSW)

- Load byte (word) at memory location DS:SI to AL (AX);
update SI according to DF and the width of the data being transferred
- It does not modify flags

❑ STOSB (STOSW)

- Store byte (word) at in AL (AX) to memory location ES:DI;
update DI according to DF and the width of the data being transferred
- It does not modify flags

Repeat Prefix Instructions

- ❑ *REPZ String Instruction*
 - Repeat the execution of the string instruction until CX=0 or zero flag is clear

- ❑ *REPNZ String Instruction*
 - Repeat the execution of the string instruction until CX=0 or zero flag is set

- ❑ *REPE String Instruction*
 - Repeat the execution of the string instruction until CX=0 or zero flag is clear

- ❑ *REPNE String Instruction*
 - Repeat the execution of the string instruction until CX=0 or zero flag is set

Loops and Conditional Jumps

All loops and conditional jumps are **SHORT** jumps, i.e., the target must be in the range of an 8-bit signed displacement (-128 to +127).

The displacement is the number that, when added to the IP, changes the IP to point at the jump target. Remember the IP is pointing at the next instruction when this occurs.

The loop instructions perform several operations at one time but do not change any flags.

LOOP decrements CX and jumps if CX is not zero.

LOOPNZ or **LOOPNE** -- loop while not zero or not equal: decrements CX and jumps if CX is not zero or the zero flag ZF = 0.

LOOPZ or **LOOPE** -- loop while zero or equal: decrements CX and jumps if CX is zero or the zero flag ZF = 1.

The conditional jump instructions often follow a compare **CMP** or **TEST** instruction. These two instructions only affect the **FLAG** register and not the destination. **CMP** does a **SUB**tract (dest - src) and **TEST** does an **AND**.

For example, if a **CMP** is followed by a **JG** (jump greater than), then the jump is taken if the destination is greater than the source.

Test is used to see if a bit or bits are set in a word or byte such as when determining the status of a peripheral device.

Conditional Jumps

<u>Name/Alt</u>	<u>Meaning</u>	<u>Flag setting</u>
JE/JZ	Jump equal/zero	ZF = 1
JNE/JNZ	Jump not equal/zero	ZF = 0
JL/JNGE	Jump less than/not greater than or =	(SF xor OF) = 1
JNL/JGE	Jump not less than/greater than or =	(SF xor OF) = 0
JG/JNLE	Jump greater than/not less than or =	((SF xor OF) or ZF) = 0
JNG/JLE	Jump not greater than/ less than or =	((SF xor OF) or ZF) = 1
JB/JNAE	Jump below/not above or equal	CF = 1
JNB/JAE	Jump not below/above or equal	CF = 0
JA/JNBE	Jump above/not below or equal	(CF or ZF) = 0
JNA/JBE	Jump not above/ below or equal	(CF or ZF) = 1
JS	Jump on sign (jump negative)	SF = 1
JNS	Jump on not sign (jump positive)	SF = 0
JO	Jump on overflow	OF = 1
JNO	Jump on no overflow	OF = 0
JP/JPE	Jump parity/parity even	PF = 1
JNP/JPO	Jump no parity/parity odd	PF = 0
JCXZ	Jump on CX = 0	---

8254 Internal Architecture

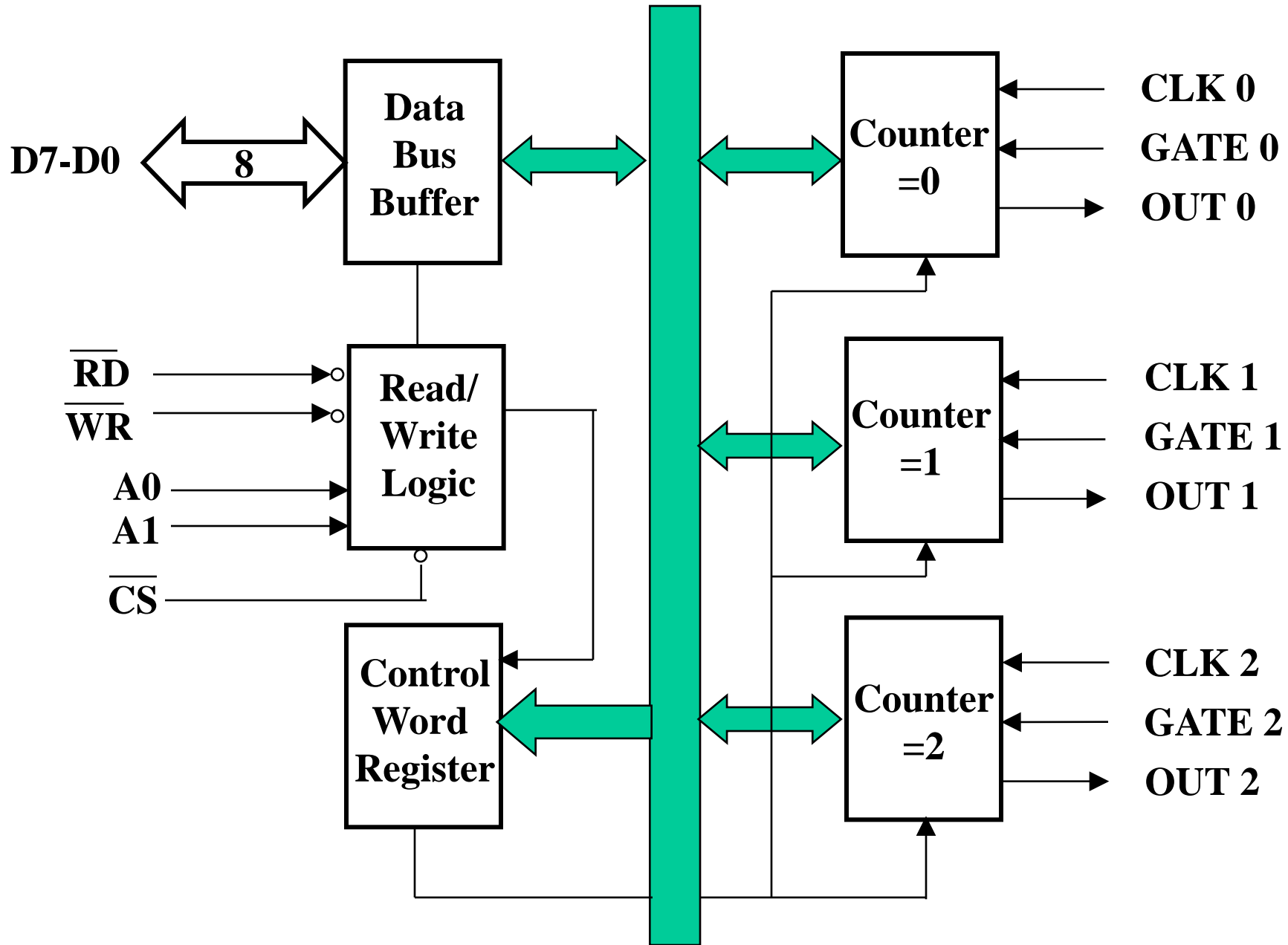

**THE CONTROL WORD REGISTER AND COUNTERS
ARE SELECTED
ACCORDING TO THE SIGNALS ON LINE
A0 and A1 AS SHOWN BELOW**

A1 A0 Selection

0	0	Counter 0
0	1	Counter 1
1	0	Counter 2
1	1	Control Register

8254 Control Word Format

SC1	SC0	RW1	RW0	M2	M1	M0	BCD
-----	-----	-----	-----	----	----	----	-----

SC1	SC0		RW1	RW0		
0	0	Select counter 0	0	0	Counter Latch Command	
0	1	Select counter 1	0	1		Read/Write least significant byte only
1	0	Select Counter 2	1	0		Read/Write most significant byte only
1	1	Read-Back command	1	1		Read/Write least significant byte first, Then the most significant byte.

BCD:

0	Binary Counter 16-bits
1	Binary Coded Decimal (BCD) Counter

M2	M1	M0	
0	0	0	Mode 0
0	0	1	Mode 1
X	1	0	Mode 2
X	1	1	Mode 3
1	0	0	Mode 4
1	0	1	Mode 5

MODE 0 : Interrupt on terminal count

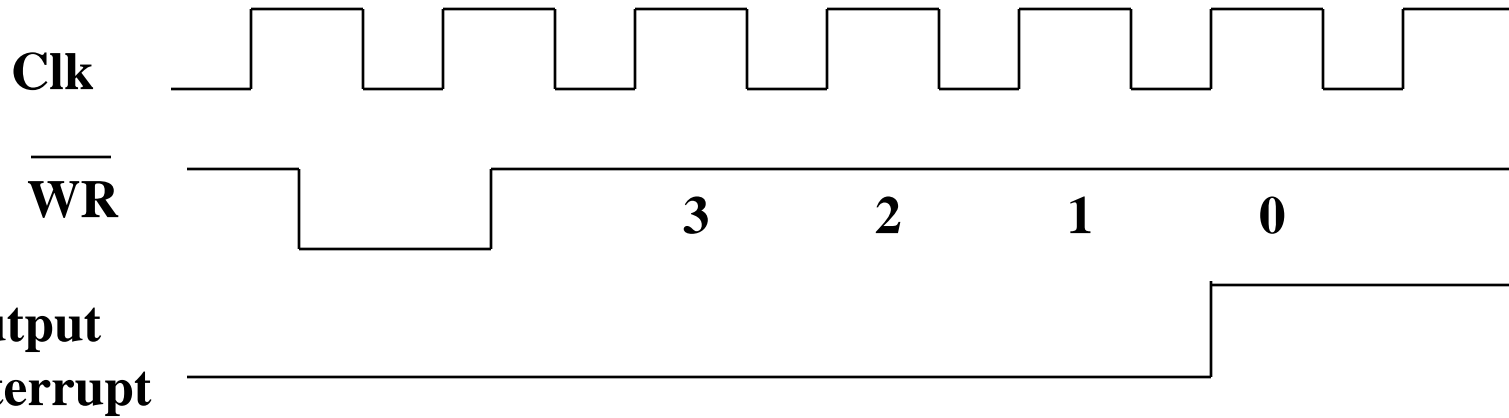

MODE 1 : HARDWARE-RETRIGGERABLE ONE-SHOT

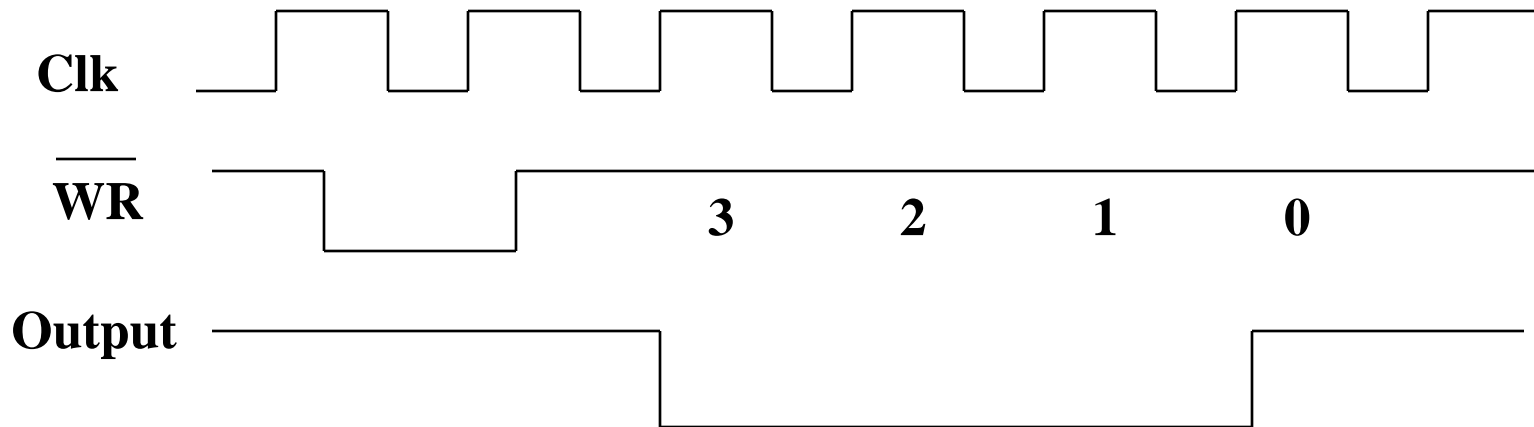

MODE 2 : RATE GENERATOR CLOCK

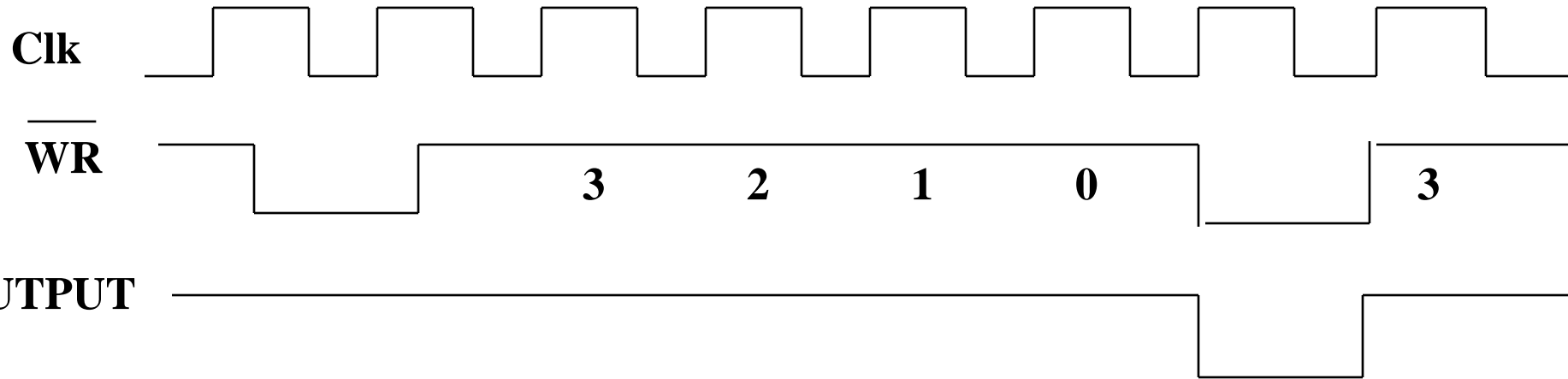

MODE 3 : Square Wave Generator

Clk

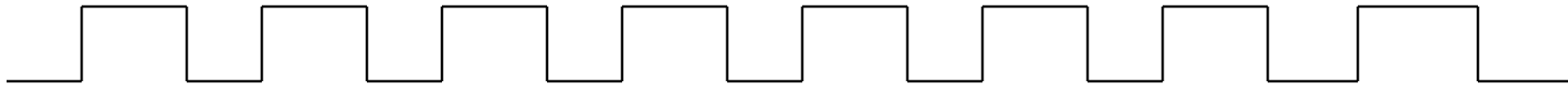

OUTPUT(n=4)



OUTPUT(n=5)

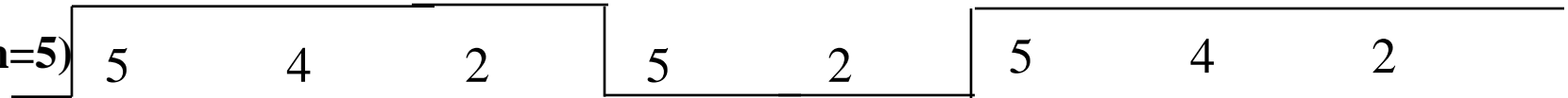

MODE 4 : SOFTWARE TRIGGERED STROBE

In this mode OUT is initially high; it goes low for one clock period at the end of the count. The count must be RELOADED -(*UNLIKE MODE 2*) for subsequent outputs.

MODE 5 : HARWARE TRIGGERED STROBE

- This mode is similar to MODE 4 except that it is triggered by the rising pulse at the gate. Initially, the OUT is low and when the GATE pulse is triggered from low to high , the count begins. At the end of the count the OUT goes low for one clock period.

READ BACK COMMAND FORMAT:

- *THIS FEATURE AVAILABLE ONLY IN 8254 and not in 8253.*

1	1	COU NT	STAT US	CNT2	CNT1	CNT0	0
---	---	-----------	------------	------	------	------	---

Data Transfer
Schemes

Why do we need data transfer schemes ?

- Availability of wide variety of I/O devices because of variations in manufacturing technologies e.g. electromechanical, electrical, mechanical, electronic etc.
- Enormous variation in the range of speed.
- Wide variation in the format of data.

Classification of Data Transfer Schemes

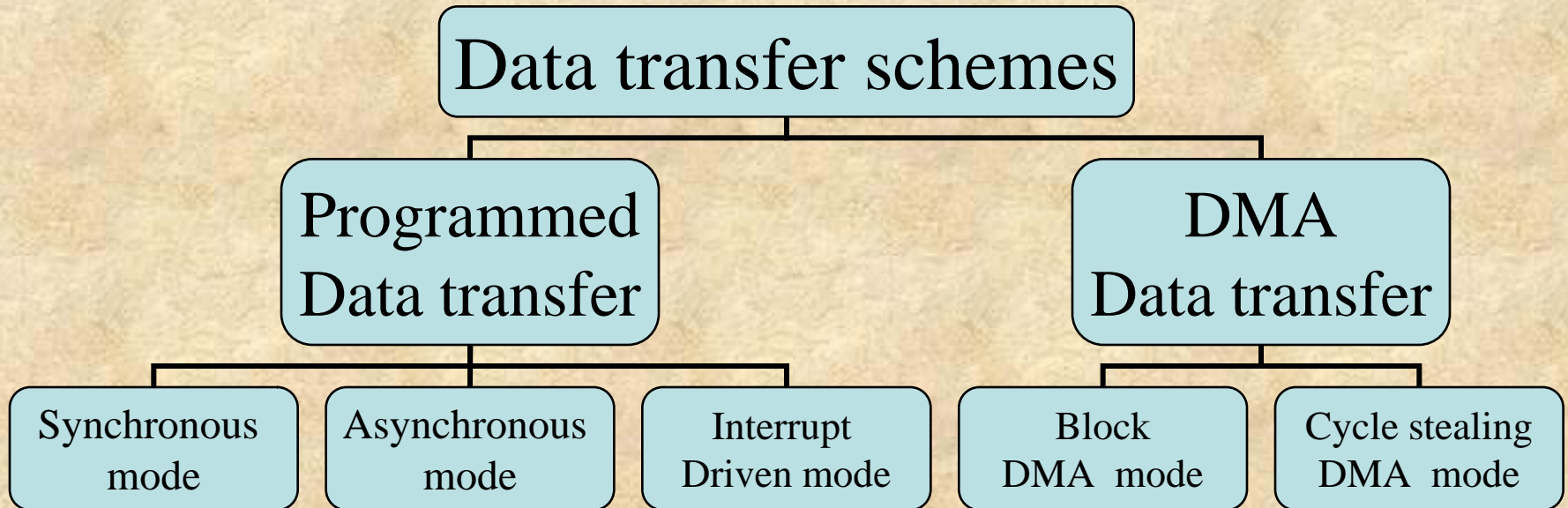

Programmed Data Transfer *Scheme*

- The data transfer takes place under the control of a program residing in the main memory.
- These programs are executed by the CPU when an I/O device is ready to transfer data.
- To transfer one byte of data, it needs to execute several instructions.
- This scheme is very slow and thus suitable when small amount of data is to be transferred.

Synchronous Mode of Data Transfer

- Its used for I/O devices whose *timing characteristics* are fast enough to be compatible in speed with the communicating MPU.
- In this case the status of the I/O device is not checked before data transfer.
- The data transfer is executed using IN and OUT instructions.

- Memory compatible with MPU are available. Hence this method is invariably used with compatible memory devices.
- The I/O devices compatible in speed with MPU are usually not available. Hence this technique is rarely used in practice

Asynchronous Data Transfer

- This method of data transfer is also called Handshaking mode.
- This scheme is used when speed of I/O device does not match with that of MPU and the timing characteristics are not predictable.
- The MPU first sends a request to the device and then keeps on checking its status.

- The data transfer instructions are executed only when the I/O device is ready to accept or supply data.
- Each data transfer is preceded by a requesting signal sent by MPU and READY signal from the device.

Disadvantages

- A lot of MPU time is wasted during looping to check the device status which may be prohibitive in many situations.
- Some simple devices may not have status signals. In such a case MPU goes on checking whether data is available on the port or not.

Interrupt Driven Data Transfer

- In this scheme the MPU initiates an I/O device to get ready and then it executes its main program instead of remaining in the loop to check the status of the device.
- When the device gets ready, it sends a signal to the MPU through a special input line called an interrupt line.
- The MPU answers the interrupt signal after executing the current instruction.

- The MPU saves the contents of the PC on the stack first and then takes up a subroutine called ISS (Interrupt Service Subroutine).
- After returning from ISS the MPU again loads the PC with the address that is just loaded in the stack and thus returns to the main program.
- It is efficient because precious time of MPU is not wasted while the I/O device gets ready.
- In this scheme the data transfer may also be initiated by the I/O device.

Multiple Interrupts

- The MPU has one interrupt level and several I/O devices to be connected to it which are attended in the order of priority.
- The MPU has several interrupt levels and one I/O device is to be connected to each interrupt level.

- The MPU has several interrupt levels and more than one I/O devices are to be connected to each interrupt level.
- The MPU executes multiple interrupts by using a device polling technique to know which device connected to which interrupt level has interrupted

Interrupts of 8085

On the basis of priority the interrupt signals are as follows

- TRAP
- RST 7.5
- RST6.5
- RST5.5
- INTR

These interrupts are implemented by the hardware

Interrupt Instructions

- EI (Enable Interrupt) This instruction sets the interrupt enable Flip Flop to activate the interrupts.
- DI (Disable Interrupt) This instruction resets the interrupt enable Flip Flop and deactivates all the interrupts except the non-maskable interrupt i.e. TRAP
- RESET This also resets the interrupt enable Flip Flop.

- SIM (Set Interrupt Mask) This enables\disables interrupts according to the bit pattern in accumulator obtained through masking.
- RIM (Read Interrupt Mask) This instruction helps the programmer to know the current status of pending interrupt.

Call Locations and Hex – codes for RST n

RST n	Hex - code	Call location
RST 0	C7	0000
RST 1	CF	0008
RST 2	D7	0010
RST 3	DF	0018
RST 4	E7	0020
RST 5	EF	0028
RST 6	F7	0030
RST 7	FF	0038

These instructions are implemented by the software

DMA Data Transfer scheme

- Data transfer from I/O device to memory or vice-versa is controlled by a DMA controller.
- This scheme is employed when large amount of data is to be transferred.
- The DMA requests the control of buses through the HOLD signal and the MPU acknowledges the request through HLDA signal and releases the control of buses to DMA.
- It's a faster scheme and hence used for high speed printers.

Block mode of data transfer

In this scheme the I/O device withdraws the DMA request only after all the data bytes have been transferred.

Cycle stealing technique

In this scheme the bytes are divided into several parts and after transferring every part the control of buses is given back to MPU and later stolen back when MPU does not need it.