

UNIT -1

Chapter-1

INTRODUCTION TO DESIGN CONSIDERATION

Prepared By: Prof. TEJAS RAVAL
Automobile Department

- Machine design is defined as the use of scientific principles, technical information and imagination in the description of a machine or a mechanical system to perform specific functions with maximum economy and efficiency.

General DESIGN PROCEDURE

1. Definition of problem
2. Synthesis
3. Analysis of forces
4. Selection of material
5. Determination of mode of failure
6. Selection of factor of safety
7. Determination of dimensions
8. Modification of dimensions
9. Preparation of drawings
10. Preparation of design report

- **Example:** The process of design of a belt drive.

DESIGN

CONSIDERATIONS

- Strength
- Rigidity
- Reliability
- Safety
- Cost
- Weight
- Ergonomics
- Aesthetics
- **Manufacturing considerations**
- Assembly considerations
- Conformance to standards

- Friction and wear
- Life
- Vibrations
- **Thermal considerations**
- Lubrication
- Maintenance
- Flexibility
- Size and shape
- Stiffness
- Corrosion
- Noise
- Environmental considerations

MANUFACTURING CONSIDERATIONS IN DESIGN

- Minimum total number of parts in a product
- Minimum variety of parts
- Use standard parts
- Use modular design
- Design parts to be multifunctional
- Design parts for multiple use
- Select least costly material
- Design parts for ease of manufacture
- Shape the parts for minimizing the operations

DESIGN CONSIDERATIONS FOR CASTINGS

- Design parts to be in compression then in tension
- Strengthen parts under tension by use of external devices
- Shape the casting for orderly solidification
- Avoid abrupt change in cross-section
- Provide more thickness at the boss
- Round off the corners
- Avoid concentration of metal at junctions
- Avoid thin sections
- Make provision for easy removal of pattern from the mould



DESIGN CONSIDERATIONS FOR FORGINGS

- Keep fibre lines parallel to tensile and compressive forces and perpendicular to shear forces
- Avoid deep machining cuts
- Keep vertical surfaces of forged parts tapered
- Keep the parting line in one plane
- Provide adequate fillet and corner radii
- Avoid thin sections



DESIGN CONSIDERATIONS IN WELDING

- Use the minimum possible number of welds
- Select the same thickness for the parts to be welded together
- Locate the welds at the areas in the design where stresses and/or deflections are not critical
- Effect of shrinkage and distortion should be minimized by post welding annealing and stress relief operations
- Decide proper welding sequence
- Design welding in the flat or horizontal position and not in the overhead position
- Use only the amount of weld metal that is absolutely required



Design for creep

- Purpose

This clause is for the **design of vessels or vessel parts and automobile engine parts**, if the calculation temperature is in the creep range. It may be applied for pressure and mechanical loading.

- Definition:
It is a time- dependent deformation under a certain applied load.
- Generally occurs at **high temperature** (thermal creep), but can also happen at room temperature in certain materials (e.g. lead or glass), albeit much slower.
- As a result, the material undergoes a time dependent increase in length, which could be dangerous while in service.

- The rate of deformation is called the creep rate.
- It is the slope of the line in a Creep Strain ϵ vs. Time curve.

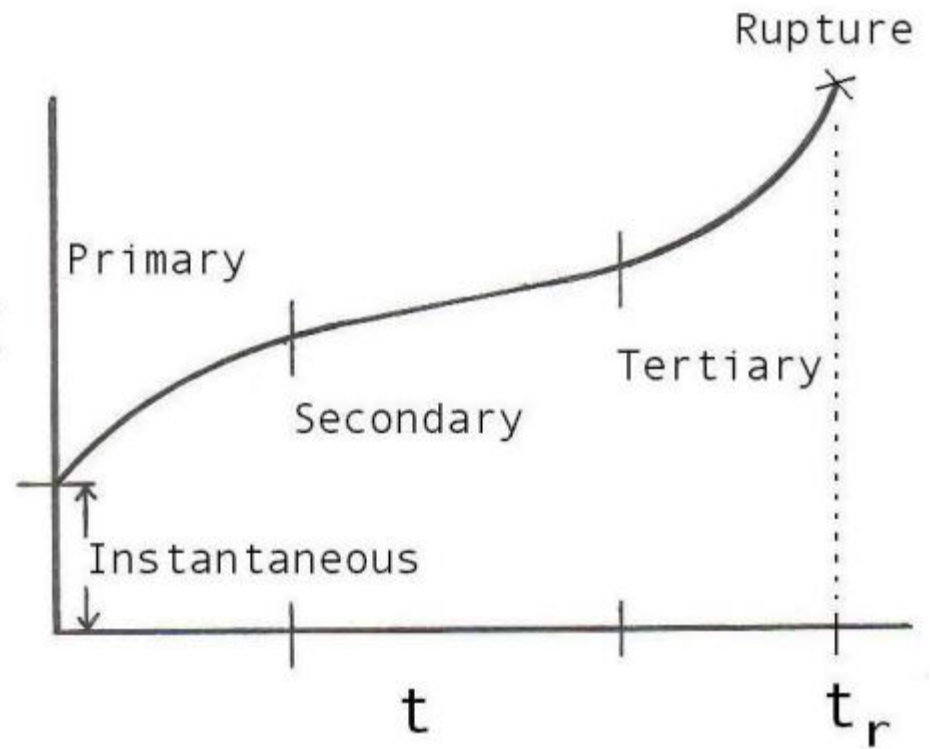

- The constant stress creep curve displays three different stages
- In the first stage called primary creep, the creep rate **gradually increase**;
- in the second stage (quasi-steady-state), the creep rate is nearly **constant**; whilst
- in the tertiary state the creep rate **increases rapidly** until the specimen breaks.
- Creep can occur by dislocation glide, climb, glide- plus-climb, lattice-diffusion, grain boundary diffusion, dislocation core diffusion and even dynamic recrystallization.

Topic End

MECHANICAL PROPERTIES OF MATERIALS

- Strength
- Stiffness/Rigidity
- Elasticity
- Plasticity
- Ductility
- Brittleness
- Malleability
- Toughness
- Machinability
- Resilience
- Creep
- Fatigue
- Hardness

AESTHETIC CONSIDERATIONS IN DESIGN

- Appearance is an outward expression of quality of the product and is the first communication of product with the user.
- Aesthetics is defined as the set of principles of appreciation of beauty. It deals with the appearance of the product.

ASPECTS OF AESTHETIC DESIGN

- Form(shape)
- Symmetry and shape
- Color
- Continuity
- Variety
- Proportion
- Noise
- Contrast
- Impression and purpose
- Style
- Material and surface finish
- Tolerance

ERGONOMICS CONSIDERATIONS IN DESIGN

- Ergonomics is defined as the study of the **man - machine - working environment** relationship
- It aims at decreasing the physical and mental stresses to the user
- **Areas covered under ergonomics**
 - Communication between man (user) and machine
 - Working environment
 - Human anatomy and posture while using the machine
 - Energy expenditure in hand and foot operations

DESIGN OF BEARINGS

Prepared By: Prof. TEJAS RAVAL
Automobile Department

Rolling contact bearing

Rolling contact bearings are also called **anti-friction bearing** due to its low friction characteristics.

These bearings are used for radial load, thrust load and combination of thrust and radial load.

These bearings are extensively used due to its relatively lower price, being almost maintenance free and for its operational ease. However, friction increases at high speeds for rolling contact bearings and it may be noisy while running.

These bearings are of two types, **Ball bearing and Roller bearing**

Ball bearing A typical ball bearing is shown the Fig.

The figure shown on the bottom side, with nomenclature, is the schematic representation of the actual bearing.

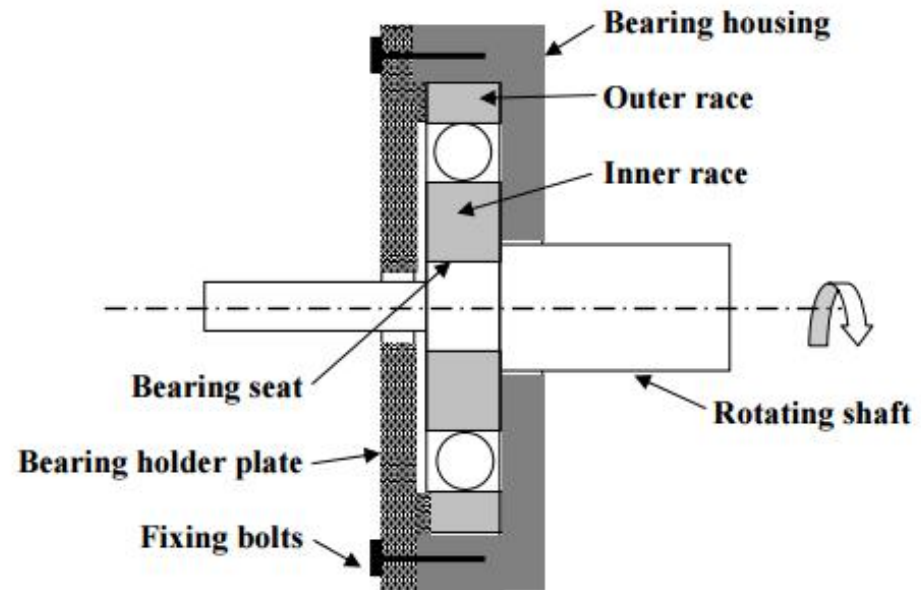
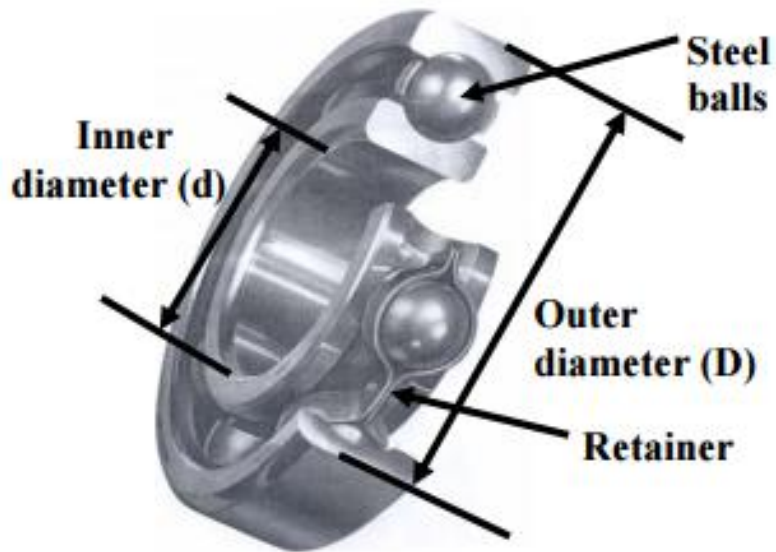

The bearing shown in the figure is called **Single row deep groove ball bearing**.

It is used to carry radial load but it can also take up considerable amount of axial load. The retainer keeps the steel balls in position and the groove below the steel balls is the inner ring and over it is the outer ring.

The outer ring, called outer race, is normally placed inside a bearing housing which is fixed, while the inner race holds the rotating shaft.

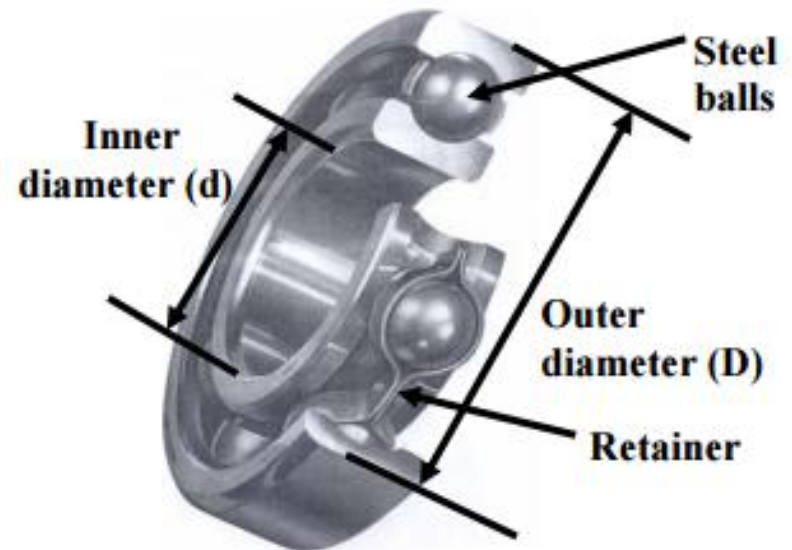

Types of Bearings

Single row Angular Contact Ball Bearing

The figure is a Single row Angular Contact Ball Bearing.

It is mostly used for **radial loads and heavy axial loads.**



Double Row Angular Contact Bearing

Double Row Angular Contact Bearing, shown in Fig. has two rows of balls.

Axial displacement of the shaft can be kept very small even for axial loads of varying magnitude.



Single thrust ball bearing

This Fig. shows a Single thrust ball bearing.

It is mostly used for **unidirectional axial load**.



Note: Roller bearings has more contact area than a ball bearing, therefore, they are generally used for heavier loads than the ball bearings.

Taper Roller Bearing

A taper roller bearing and its nomenclature are shown in Fig.

It is generally used for simultaneous **heavy radial load and heavy axial load**.



Spherical Roller Bearing

A spherical roller bearing, shown in the Fig. has self aligning property. It is mainly used **for heavy axial loads.**

However, considerable amount of loads in either direction can also be applied.



Cylindrical Roller Bearing

It is used for **heavy radial load and high speed.**

Within certain limit, relative axial displacement of the shaft and the bearing housing is permitted for this type of bearings.



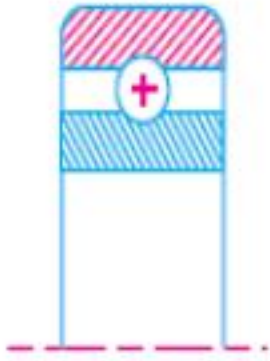

(a) Single row deep groove.



(b) Filling notch.

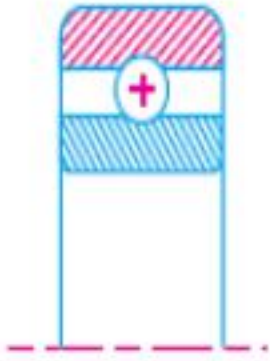

(c) Angular contact.

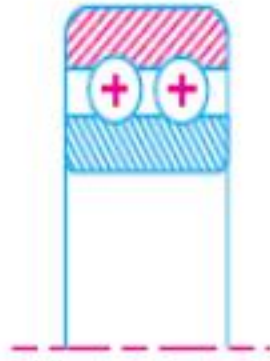

(d) Double row.

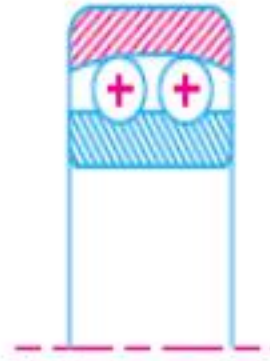

(e) Self-aligning.

Types of radial ball bearings.

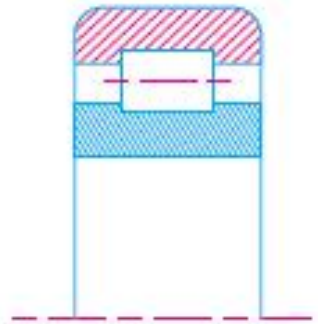

(a) Cylindrical roller.

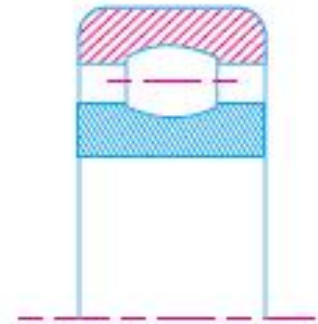

(b) Spherical roller.

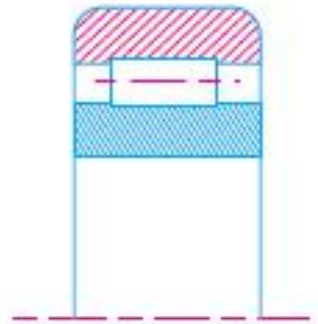

(c) Needle roller.

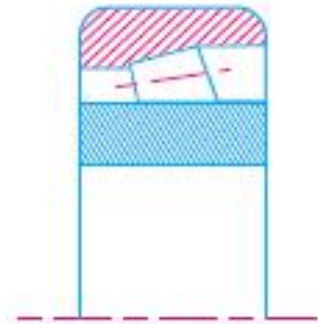

(d) Tapered roller.

Types of roller bearings

Advantages and Disadvantages of Rolling Contact Bearings Over Sliding Contact Bearings

Advantages

1. Low starting and running friction except at very high speeds.
2. Ability to withstand momentary shock loads.
3. Accuracy of shaft alignment.
4. Low cost of maintenance, as no lubrication is required while in service.
5. Small overall dimensions.
6. Reliability of service.
7. Easy to mount and erect.
8. Cleanliness.

Disadvantages

1. More noisy at very high speeds.
2. Low resistance to shock loading.
3. More initial cost.
4. Design of bearing housing complicated.

Types of Rolling Contact Bearings

Following are the two types of rolling contact bearings:

1. Ball bearings; and 2. Roller bearings.

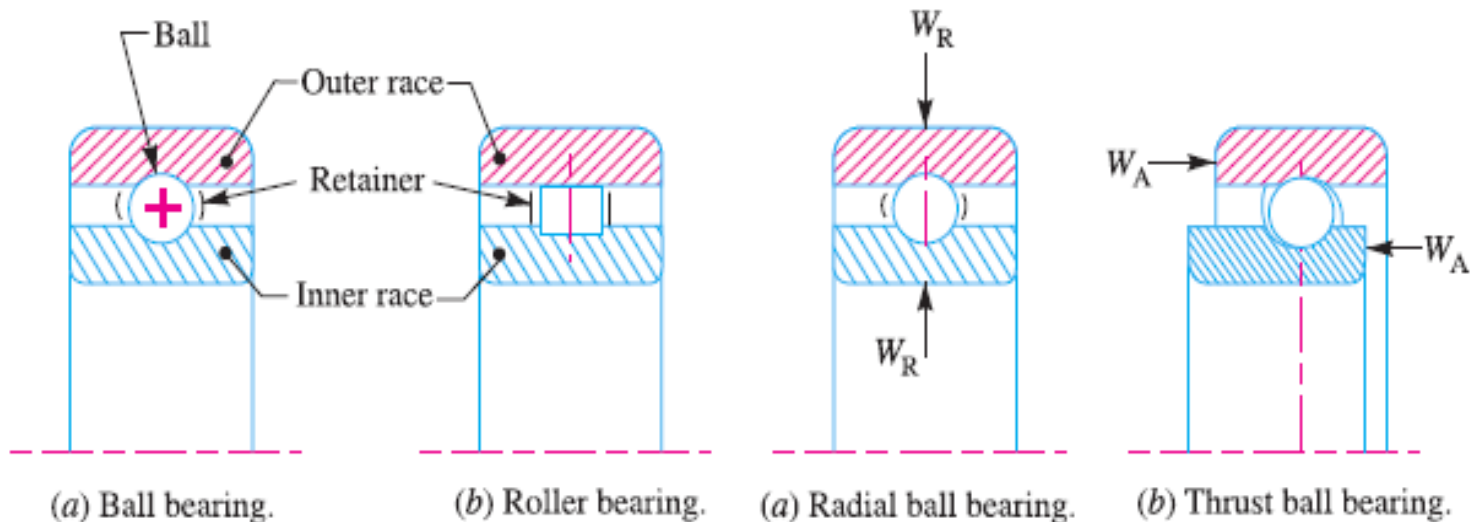

The ***ball and roller bearings consist of an inner race which is mounted on the shaft or journal*** and an outer race which is carried by the housing or casing. In between the inner and outer race, there are balls or rollers as shown in Fig. A number of balls or rollers are used and these are held at proper distances by retainers so that they do not touch each other. The retainers are thin strips and is usually in two parts which are assembled after the balls have been properly spaced. The ball bearings are used for light loads and the roller bearings are used for heavier loads. The rolling contact bearings, depending upon the load to be carried, are classified as :

(a) Radial bearings, and (b) Thrust bearings.

The radial and thrust ball bearings are shown in Fig. *(a) and (b) respectively. When a ball bearing supports only a radial load (WR), the plane of rotation of the ball is normal to the centre line of the bearing, as shown in Fig(a). The action of thrust load (WA) is to shift the plane of rotation of the balls, as shown in Fig (b). The radial and thrust loads both may be carried simultaneously.*

Types of Radial Ball Bearings

1. **Single row deep groove bearing.** *A single row deep groove bearing is shown in Fig (a).* During assembly of this bearing, the races are offset and the maximum number of balls are placed between the races. The races are then centred and the balls are symmetrically located by the use of a retainer or cage. The deep groove ball bearings are used due to their high load carrying capacity and suitability for high running speeds. The load carrying capacity of a ball bearing is related to the size and number of the balls.

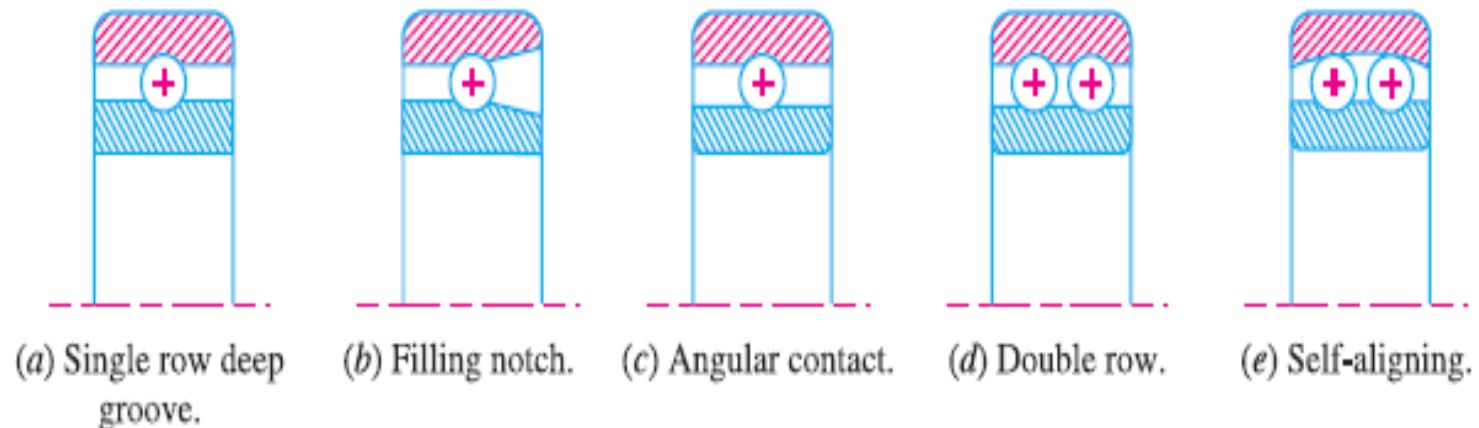

- 2. Filling notch bearing.** A filling notch bearing is shown in Fig (b). *These bearings have notches in the inner and outer races which permit more balls to be inserted than in a deep groove ball bearings. The notches do not extend to the bottom of the race way and therefore the balls inserted through the notches must be forced in position. Since this type of bearing contains larger number of balls than a corresponding unnotched one, therefore it has a larger bearing load capacity.*
- 3. Angular contact bearing.** *An angular contact bearing is shown in Fig (c). These bearings have one side of the outer race cut away to permit the insertion of more balls than in a deep groove bearing but without having a notch cut into both races. This permits the bearing to carry a relatively large axial load in one direction while also carrying a relatively large radial load. The angular contact bearings are usually used in pairs so that thrust loads may be carried in either direction.*
- 4. Double row bearing.** *A double row bearing is shown in Fig (d). These bearings may be made with radial or angular contact between the balls and races. The double row bearing is appreciably narrower than two single row bearings. The load capacity of such bearings is slightly less than twice that of a single row bearing.*
- 5. Self-aligning bearing.** *A self-aligning bearing is shown in Fig (e). These bearings permit shaft deflections within 2-3 degrees. It may be noted that normal clearance in a ball bearing are too small to accommodate any appreciable misalignment of the shaft relative to the housing. If the unit is assembled with shaft misalignment present, then the bearing will be subjected to a load that may be in excess of the design value and premature failure may occur. Following are the two types of self-aligning bearings :*
- (a) Externally self-aligning bearing, and (b) Internally self-aligning bearing.**
- In an externally self-aligning bearing, the outside diameter of the outer race is ground to a spherical surface which fits in a mating spherical surface in a housing, as shown in Fig (e). In case of internally self-aligning bearing, the inner surface is spherical. Consequently, the outer race may be displaced through a small angle without interfering with the normal operation of the bearing. The internally self-aligning ball bearing is interchangeable with other ball bearings.*

Thrust Ball Bearings

The thrust ball bearings are used for carrying thrust loads exclusively and at speeds below 2000 r.p.m. At high speeds, centrifugal force causes the balls to be forced out of the races. Therefore at high speeds, it is recommended that angular contact ball bearings should be used in place of thrust ball bearings.

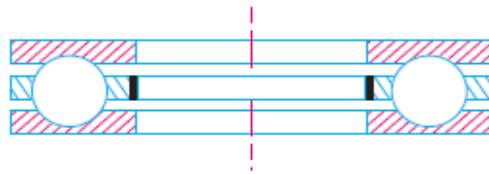

(a) Single direction thrust ball bearing.

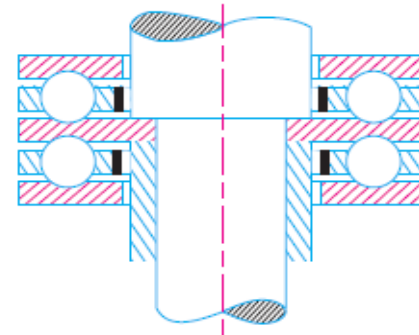

(b) Double direction thrust ball bearing.

A thrust ball bearing may be a single direction, flat face as shown in Fig (a) or a double direction with flat face as shown in Fig (b).

Types of Roller Bearings

1. **Cylindrical roller bearings.** *A cylindrical roller bearing is shown in Fig (a).* **These** bearings have short rollers guided in a cage. These bearings are relatively rigid against radial motion and have the lowest coefficient of friction of any form of heavy duty rolling-contact bearings. Such type of bearings are used in high speed service.
2. **Spherical roller bearings.** A spherical roller bearing is shown in Fig (b). These bearings are self-aligning bearings. The self-aligning feature is achieved by grinding one of the races in the form of sphere. These bearings can normally tolerate angular misalignment in the order of $\pm 1\frac{1}{2}^\circ$ and when used with a double row of rollers, these can carry thrust loads in either direction.

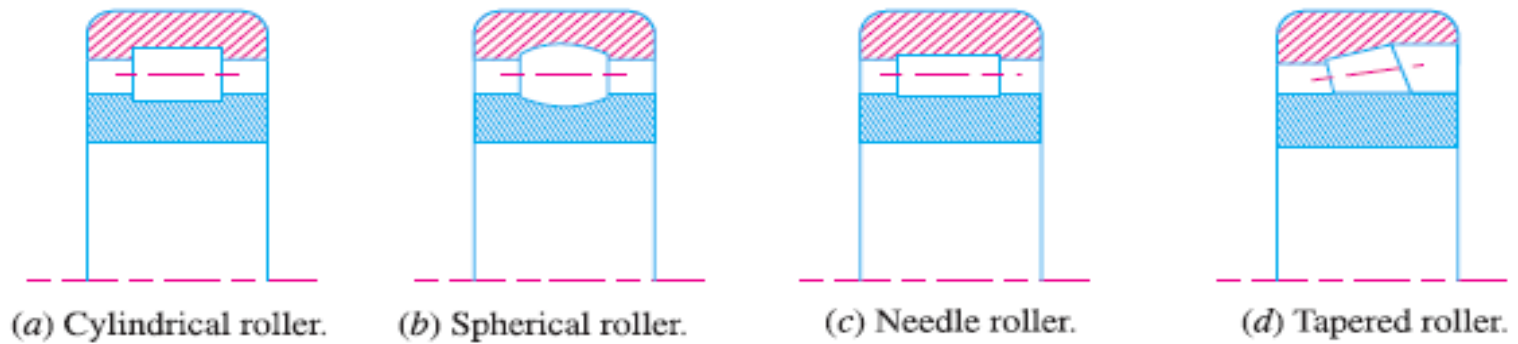

- 3. Needle roller bearings.** *A needle roller bearing is shown in Fig (c). These bearings are relatively slender and completely fill the space so that neither a cage nor a retainer is needed. These bearings are used when heavy loads are to be carried with an oscillatory motion, e.g. piston pin bearings in heavy duty diesel engines, where the reversal of motion tends to keep the rollers in correct alignment.*
- 4. Tapered roller bearings.** *A tapered roller bearing is shown in Fig (d). The rollers and race ways of these bearings are truncated cones whose elements intersect at a common point. Such type of bearings can carry both radial and thrust loads. These bearings are available in various combinations as double row bearings and with different cone angles for use with different relative magnitudes of radial and thrust loads.*