

Vehicle dimension limits

Purpose

This Vehicle Standards Information (VSI) No. 5 is intended to provide information on the dimension limits that apply to vehicles registered for use on NSW roads and road-related areas.

Introduction

In NSW, dimension limits relating to width, height and length, and some internal dimensions of vehicles, are prescribed in the Road Transport (Vehicle Registration) Regulation 2007 (the Regulation). The Road Transport (Mass, Loading and Access) Regulation 2005 (the MLAs) also prescribes dimension limits relating to size and projection of loads.

These dimension limits are set to ensure vehicles using the road network have adequate manoeuvrability and are compatible with the road systems and other road users.

Classification

Vehicles are generally separated into two categories; 'general access vehicles' or 'restricted access vehicles'.

GENERAL ACCESS VEHICLES

General access vehicles, including combinations, are those that alone or together with any load, do not exceed any of the following limits:

- a mass limit prescribed in Schedule 1 of the MLAs
- one or more of the following dimension limits:
 - a width of 2.5 metres
 - a height of 4.3 metres
 - a length of 12.5 metres in the case of a single motor vehicle or 19 metres in the case of a combination
- any other dimension limit prescribed in the Regulation or the MLAs.

A general access vehicle may operate on any road, except where a load or dimension restriction is indicated by a sign.

Transport for NSW

Level 4, 18 Lee Street, Chippendale NSW 2008
PO Box K659 Haymarket NSW 1240
www.transport.nsw.gov.au

RESTRICTED ACCESS VEHICLES

A restricted access vehicle means a single motor vehicle or a combination which alone or together with any loads, exceeds a general access dimension limit, or mass limit prescribed in the MLAs.

A restricted access vehicle may only operate in accordance with a relevant Notice or Permit.

Notices are available to download from the website www.rms.nsw.gov.au. Permits are issued by the Roads and Maritime Services (RMS) Special Permits Unit (see page 20 for contact details). Unless stated otherwise, it is a requirement that the applicable Notice or Permit must be carried in the driving compartment of the vehicle.

Unless specified under a Notice, a vehicle that exceeds a prescribed dimension limit, is overmass, has dual control or left-hand drive, requires written approval from RMS to be registered so as to operate on NSW roads and road related areas. Exemption from the Regulation is considered on an individual basis; VSI No. 46 *Registration of non-conforming special purpose vehicles* contains a form for gathering information on each vehicle to determine whether the vehicle may be registered, and if so, what operating conditions apply.

Table of contents

1. MOTORCYCLES	3
2. RIGID VEHICLES	
2A. General access rigid vehicles	
Rigid vehicles including special purpose vehicles (SPVs)	3
2B. Restricted access rigid vehicles, other than buses	
Rigid vehicles including special purpose vehicles (SPVs)	4
3. TRAILERS	
3A. General access trailers	
Pig trailer, including plant	4
Dog trailer, including plant	5
Semi-trailer, including plant, and car carrier	5
Low loader trailer	6
3B. Restricted access trailers	
Low loader trailer	6
Semi-trailer	7
Refrigerated semi-trailer	7
4. BUSES, INCLUDING COACHES	
4A. General access buses	
Bus/coach	7
Articulated ('bendy') bus	8
4B. Restricted access buses	
Controlled access bus or coach over 12.5 metres up to 14.5 metres	8
Double-deck bus	8
5. COMBINATIONS/ARTICULATED VEHICLES	
5A. General access combinations	
Rigid vehicle (truck) and dog trailer	9
Rigid vehicle and pig trailer	9
Prime mover and semi-trailer	9
Prime mover and low loader trailer	9
B-Double	9
5B. Restricted access combinations	
Truck and dog trailer – hauling unit exceeds 42.5 tonnes GCM	10
Prime mover and semi-trailer	10
Prime mover and low loader trailer	10
Car carrier - rigid truck and semi-trailer ('stinger')	11

Car carrier - prime mover & semi-trailer; not designed to carry load over driving compartment	11
Car carrier - prime mover & semi-trailer; designed to carry load over driving compartment	12
B-Doubles - 19m, 25m, 26m	12, 13
B Double towing a converter dolly	13
Prime mover and semi-trailer towing a converter dolly	13
Road trains	13, 14
6. OTHER REQUIREMENTS	
Height	15
Width	15
Turning circle	15
Ground clearance	15
Projection of mirrors	16
Projecting loads or equipment – light vehicles	16
Projecting loads – heavy vehicles	17
Rear overhang	18
Axles and axle groups	19
7. AGRICULTURAL VEHICLES	19
8. GLOSSARY	20

1. Motorcycles



For dimension limits on motorcycles see VSI No. 28 *Guidelines for modifications to motorcycles*.

2. Rigid vehicles



2A. GENERAL ACCESS RIGID VEHICLES

The dimensions shown in this section are the maximum allowable for general access rigid vehicles as defined in the Regulation. In addition to the following limits, general access vehicles must meet all other applicable requirements described in 'Other requirements' on pages 15 to 19.

For rigid vehicles exceeding any dimension shown in this section, see 'Restricted access rigid vehicles' on page 4.

For more information on rear overhang, see page 18.

For information on twinsteer axle groups, see page 19.

General access rigid vehicles, including special purpose vehicles (SPVs)

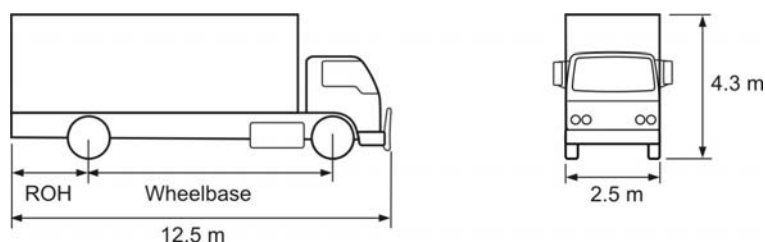

Rear overhang (ROH): 60% of the wheelbase or 3.7 metres, whichever is the lesser

2B. RESTRICTED ACCESS RIGID VEHICLES (OTHER THAN BUSES)

The dimensions shown in this section are the maximum allowable for rigid vehicles that exceed any of the general access dimensions described on page 3. Unless otherwise approved, restricted access vehicles must also meet all other applicable requirements described in 'Other requirements' on pages 15 to 19.

A restricted access vehicle may only operate with the relevant Notices and/or Permits. Some vehicles e.g. overmass, dual control or left-hand drive vehicles, may also require specific approval from RMS to be registered and to operate on NSW roads.

Restricted access rigid special purpose vehicles (SPVs)

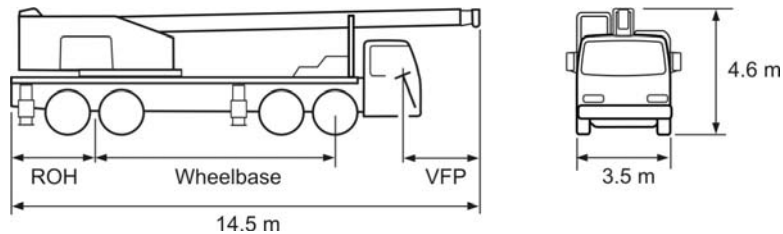

- Rear overhang (ROH): 90% of the wheelbase or 4.0 metres, whichever is the lesser
 Vehicle forward projection (VFP): 3.5 metres from the centre of the steering wheel, included in overall length

3. Trailers



3A. GENERAL ACCESS TRAILERS

The dimensions shown in this section are the maximum allowable for general access trailers as defined in the Regulation. In addition to the following limits, general access trailers must meet all other applicable requirements as described in 'Other requirements' on pages 15 to 19.

General access trailers include complying plant trailers, for example, air compressors, concrete mixers and drilling rigs.

For trailers exceeding any dimension/s shown in this section, refer to 'Restricted access trailers' on pages 6 and 7.

Trailers that otherwise exceed the dimension limits set out in this publication or are overmass require approval from RMS for registration – see 'Restricted access vehicles' on page 2.

General access pig trailer, including plant

A 'pig' trailer is a trailer that has only one axle group near the middle of the length of the goods carrying surface. Examples of a pig trailer include a box trailer and a boat trailer.

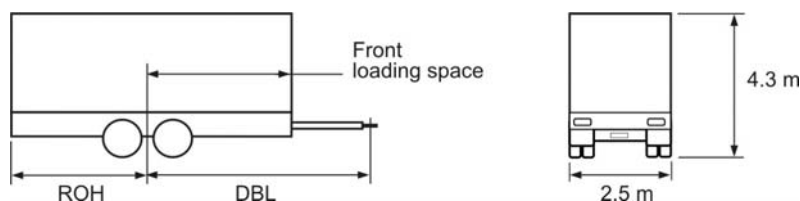

- Rear overhang (ROH): No more than the length of front loading space or 3.7 metres, whichever is the lesser
 Drawbar length (DBL): Measured from the centre of the axle/axle group to the centre of the drawbar coupling pivot point with the drawbar level, must not be more than 8.5 metres

General access dog trailer, including plant

A 'dog' trailer is a trailer that has a front axle or axle group steered by a drawbar attached to a towing vehicle, and a rear axle or axle group. A combination consisting of a semi-trailer and a converter dolly is also considered to be a dog trailer.

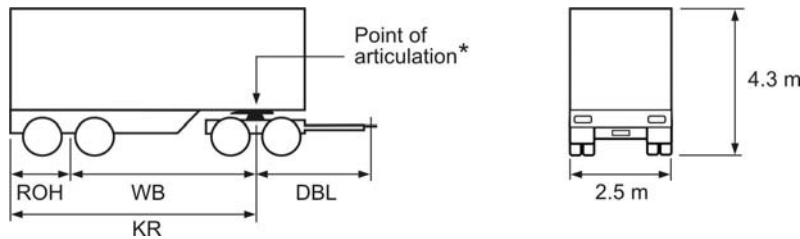

- Rear overhang (ROH): 60% of the wheelbase or 3.7 metres, whichever is the lesser
 Wheelbase (WB): 9.5 metres
 Drawbar length (DBL): Measured from the centre of the front axle/axle group to the centre of the drawbar coupling pivot point with the drawbar level, must not be more than 5 metres, and not less than 3 metres in the case of a trailer used in a road train over 19 metres in length
 Kingpin to rear (KR): 12.3 metres

*If the point of articulation (kingpin) is adjustable longitudinally, all internal dimensions (ROH, WB, DBL and KR) must comply with the above limits when measured at any point of kingpin adjustment.

General access semi-trailer, including plant and car carrier

A semi-trailer has a single axle or axle group towards the rear, with a means of attachment to a prime mover that imposes some of the load on the prime mover. Semi-trailers include pole-type trailers.

The length of a semi-trailer does not include any refrigeration or other auxiliary equipment or any loading space of a reduced width at the front of the semi-trailer within the arc created by the kingpin radius.

A trailer built to carry cattle, sheep, pigs or horses on two or more partly or completely overlapping decks must not have more than 12.5 metres of its length available for the carriage of animals, measured from the inside of the front wall or door of the trailer to the inside of the rear wall or door of the trailer, with any intervening partitions disregarded.

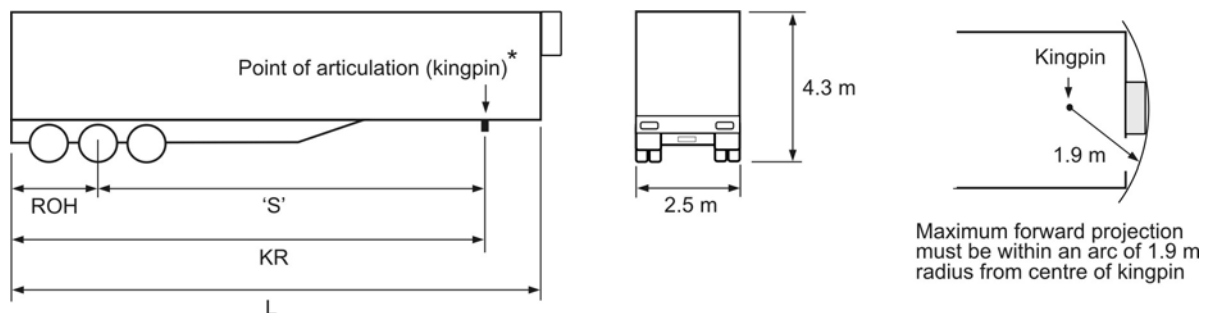

- Rear overhang (ROH): 60% of 'S' dimension or 3.7 metres, whichever is the lesser
 'S' dimension: 9.5 metres (see 'Glossary' on page 20 for explanation of 'S' dimension)
 Kingpin to rear (KR): 12.3 metres
 Length (L): No specific limit, however, when combined with a prime mover, the overall combination length must not exceed 19 metres

*If the point of articulation (kingpin) is adjustable longitudinally, all internal dimensions (ROH, 'S' and KR) must comply with the above limits when measured at any point of kingpin adjustment.

General access low loader trailer

A low loader trailer is a 'goose-neck' type semi-trailer that has a load carrying deck not more than one metre above the ground over its entire length. The area above the goose-neck may be used for equipment storage e.g. spare wheels, tools etc. A low loader is allowed general access only if it also meets the statutory mass limits.

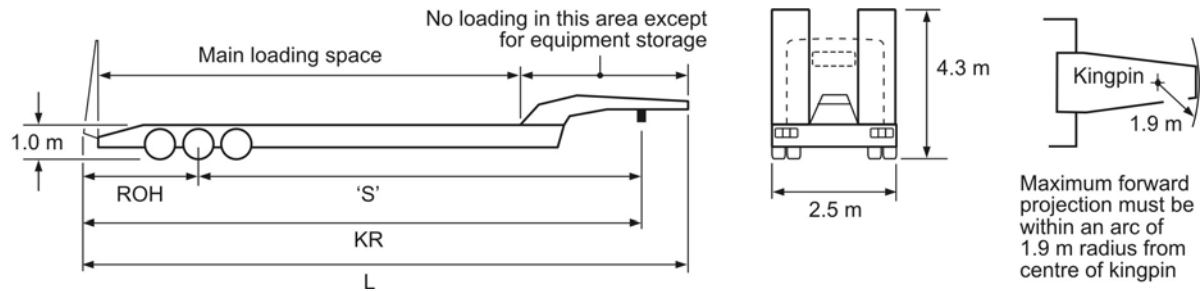

- Rear overhang (ROH): 60% of 'S' dimension or 3.7 metres, whichever is the lesser
- 'S' dimension: No specific limit
- Kingpin to rear (KR): No specific limit
- Length (L): No specific limit, however, when combined with a prime mover, the overall combination length must not exceed 19 metres

3B. RESTRICTED ACCESS TRAILERS

Extendible semi-trailers and trailers with sliding axles must conform to the applicable dimensional requirements when not carrying an indivisible load.

A semi-trailer may exceed 13.7 metres in length, but not 14.63 metres, if operated in accordance with the 'Class 3 Semi-Trailer Exemption Notice 2012'.

Plant trailers cannot have any load carrying space except for equipment essential for the operation of the trailer. For example, piping in the case of a concrete pumping unit or drills in the case of a drilling rig, and if these items make the trailer overmass or overdimension they must be removed for travel.

Trailers in this category are limited to a maximum height of 4.6 metres, laden or unladen. In this case the vehicle must operate under the '4.6 Metre High Vehicle Route Notice 2008'.

Unless otherwise approved, restricted access trailers must also meet all other applicable requirements described in 'Other requirements' on pages 15 to 19.

Restricted access low loader trailer

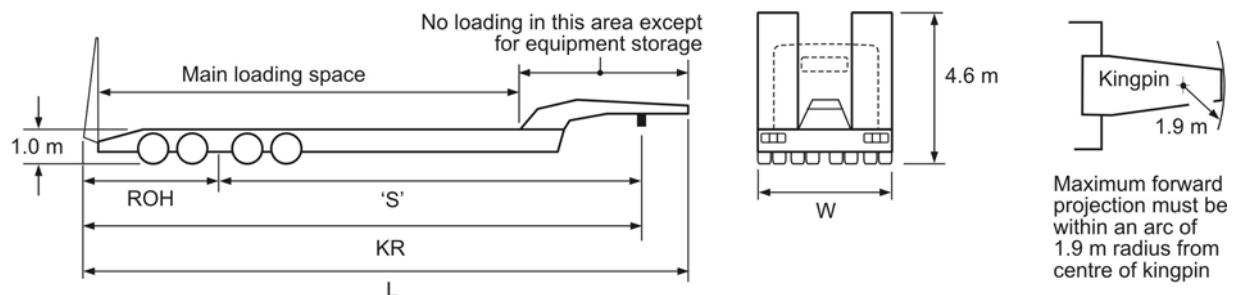

- Rear overhang (ROH): 60% of 'S' dimension or 3.7 metres, whichever is the lesser
- 'S' dimension: No specific limit
- Kingpin to rear (KR): No specific limit
- Length (L): No specific limit, however, when combined with a prime mover, the overall combination length must not exceed 25 metres
- Width (W): 2.5 metres (2.7 metres for low loaders fitted with eight tyres on each axle)

Restricted access semi-trailer

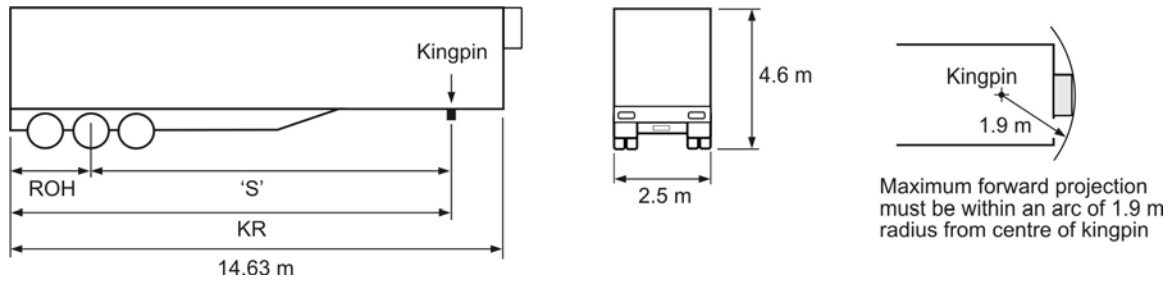

- Rear overhang (ROH): 60% of 'S' dimension or 3.7 metres, whichever is the lesser
- 'S' dimension: 9.5 metres
- Kingpin to rear (KR): No specific limit if operated in accordance with the 'Class 3 Semi-Trailer Exemption Notice 2012'

Restricted access refrigerated semi-trailer

Refrigerated semi-trailers operating under the 'Refrigerated Semi-Trailer Exemption Notice 2008' are allowed the following dimensions:

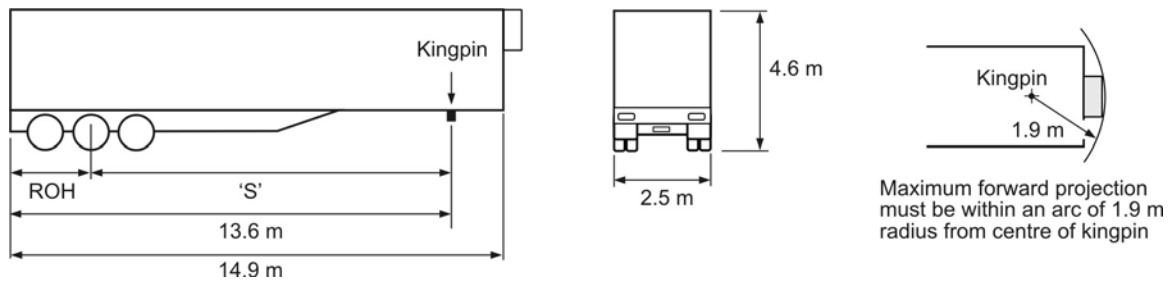

- Rear overhang (ROH): 60% of 'S' dimension or 3.7 metres, whichever is the lesser
- 'S' dimension: 9.9 metres

4. Buses (including coaches)



4A. GENERAL ACCESS BUSES

General access bus/coach

A bus is a motor vehicle built mainly to carry people that seats more than nine adults, including the driver.

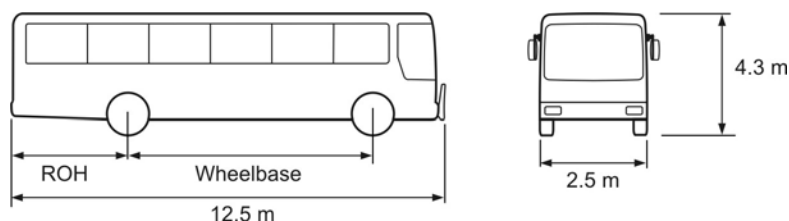

- Rear overhang (ROH): 60% of the wheelbase or 3.7 metres, whichever is the lesser

General access articulated ('bendy') bus

An articulated bus consists of at least 2 rigid sections connected to allow rotary movement, and passenger access, between the sections.

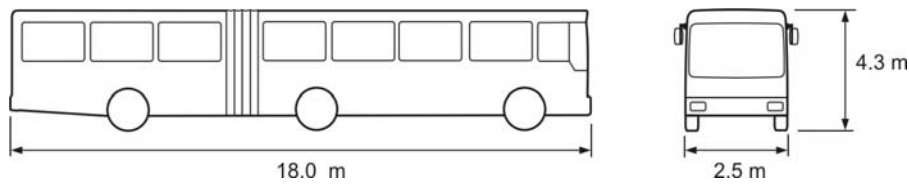

Turning circle, articulated bus

All parts, except mirrors and signalling devices, must be able to turn within a track with an inner radius of 5.3 metres and an outer radius of 12.0 metres.

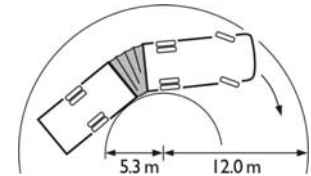

4B. RESTRICTED ACCESS BUSES

Controlled [restricted] access bus/coach over 12.5 metres up to 14.5 metres

A controlled access bus is a bus, other than an articulated bus, that is more than 12.5 metres long. These buses may only operate on approved routes as set out in the 'Class 2 Controlled Access Bus Notice 2010'.

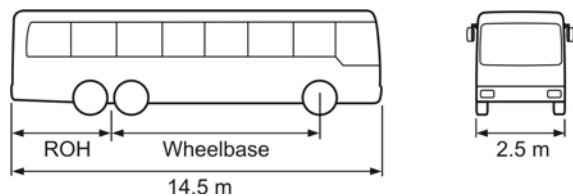

Rear overhang (ROH): 70% of the wheelbase or 4.9 metres, whichever is the lesser

Restricted access double-deck bus

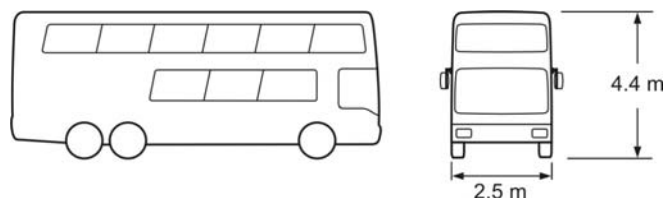

5. Combinations/articulated vehicles



5A. GENERAL ACCESS COMBINATIONS

The dimensions shown in this section are the maximum allowable for general access combinations/ articulated vehicles as described in the Regulation.

For combinations exceeding any dimension/s shown in this section, refer to 'Restricted access combinations' on page 10.

In addition to the following limits, general access combinations must also meet all other applicable requirements described in 'Other requirements' on pages 15 to 19.

General access rigid vehicle (truck) and dog trailer

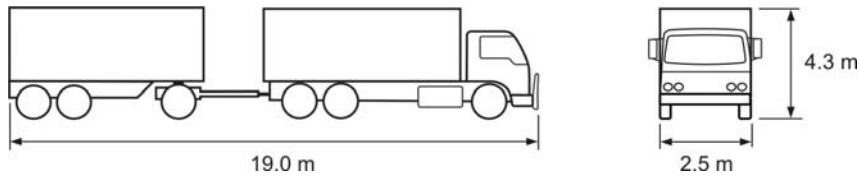

Note: If the hauling unit has a gross combination mass (GCM) in excess of 42.5 tonnes the combination may operate at more than 42.5 tonnes as a 'restricted access' vehicle combination under the 'Class 3 Truck and Dog Trailer Combination Notice 2010' – see page 10.

General access rigid vehicle and pig trailer

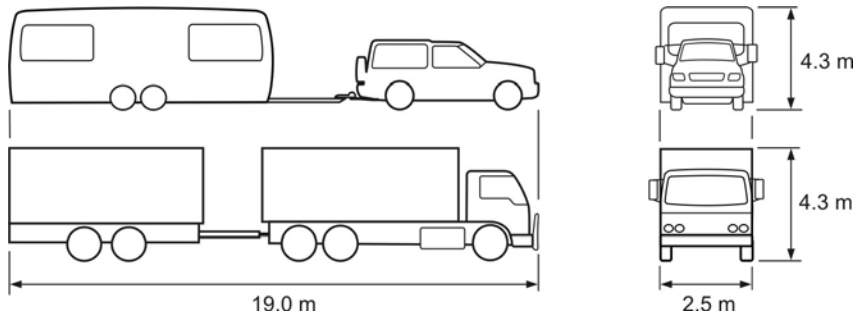

General access prime mover and semi-trailer

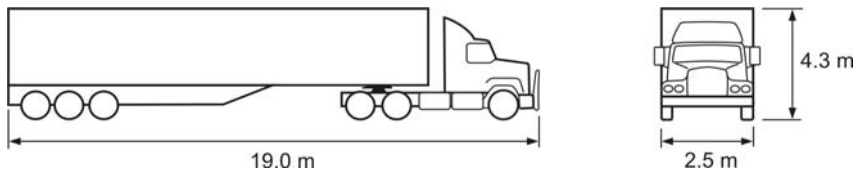

General access prime mover and low loader trailer

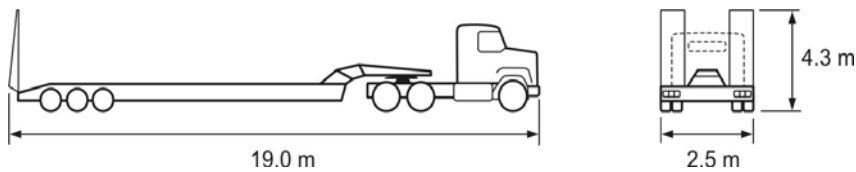

General access B-Double

A B-Double that does not exceed 19 metres in length and does not have a mass exceeding 50 tonnes may operate on any road except where indicated by a sign posted on a particular road or in a particular area.

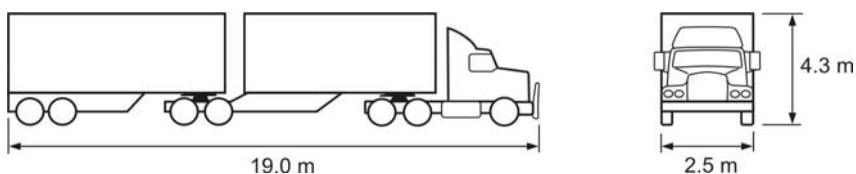

5B. RESTRICTED ACCESS COMBINATIONS

Restricted access combinations/articulated vehicles include, but are not limited to:

- vehicle combinations longer than 19.0 metres. Examples include B-Doubles, road trains and low loader combinations.
- vehicles more than 4.3 metres high. Examples include livestock crates, loaded car carriers and other commodity carriers. These vehicles may only operate on an approved route as set out in the '4.6 Metre High Vehicle Route Notice 2008'.
- vehicles carrying indivisible loads, and operating under a 'General Class 1 Oversize Notice', or specific Permit
- special purpose vehicles (SPVs) that exceed general access dimensions or mass limits
- truck and dog trailer combinations where the truck mass is in excess of 42.5 tonnes
- agricultural vehicles that exceed general access dimensions or mass limits.

Unless otherwise approved, restricted access combinations must also meet all other applicable requirements described in 'Other requirements' on pages 15 to 19.

Restricted access truck and dog trailer

If the hauling unit of a truck and dog trailer combination has a GCM in excess of 42.5 tonnes the combination may operate up to 50 tonnes under the 'Class 3 Truck and Dog Trailer Combination Notice 2010' (the Notice) provided that:

- the axle spacings of the combination are within the limits detailed in the Notice
- the height of the load on any three axle dog trailer in this combination (HLT in diagram below) does not exceed 3.5 metres
- all other requirements of the Notice are met.

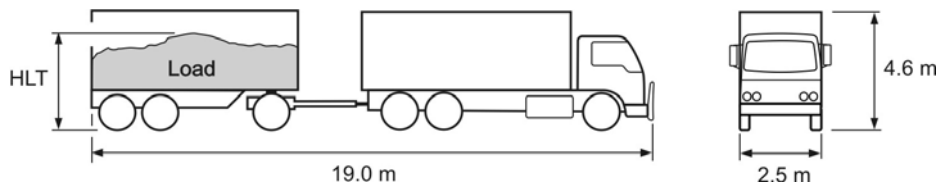

Restricted access prime mover and semi-trailer



Restricted access prime mover and low loader trailer

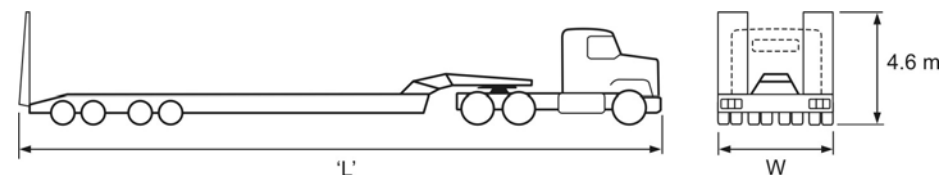

Width (W): 2.5 metres, or 2.7 metres for low loader trailers fitted with eight tyres on each axle. The prime mover must not exceed 2.5 metres width

Length (L): May exceed 19 metres subject to the 'Class 1 Load Carrying Vehicles Notice 2012' or a specific Permit

Restricted access car carrier comprising rigid truck and semi-trailer

A car carrier combination may have an overall laden length of up to 25 metres if the hauling unit is designed to carry a load in addition to a load over the driving compartment. This combination is commonly referred to as a 'stinger'.

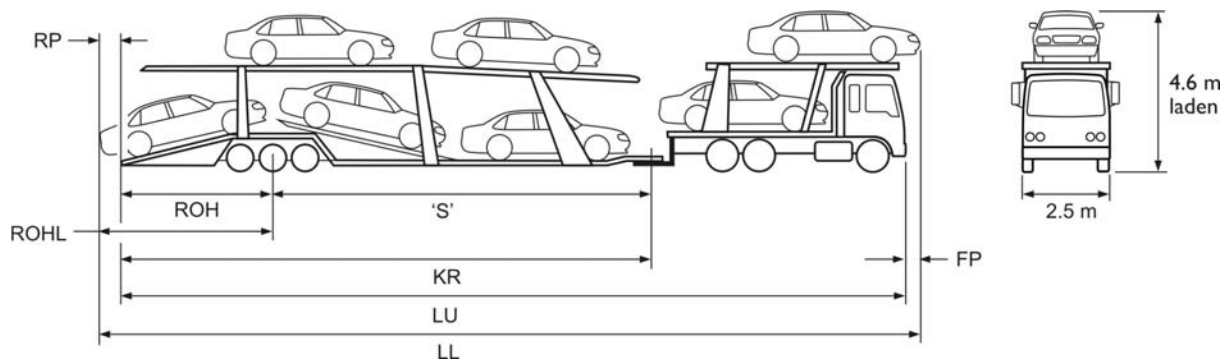

- Rear projection (RP): 1.2 metres rearward of the constructed length of the trailer, included in laden length 'LL'
- Rear overhang (ROH): 60% of 'S' dimension or 3.7 metres, whichever is the lesser
- Rear overhang limit (ROHL): 4.9 metres when laden
- 'S' dimension: 9.5 metres
- Kingpin to rear (KR): May exceed 12.3 metres if the semi-trailer is operating under the 'Class 3 Semi-Trailer Exemption Notice 2012'
- Forward projection (FP): 1.2 metres in front of headlights, included in laden length 'LL'
- Length unladen (LU): A car carrier combination with a hauling unit designed to carry a load in addition to a load above the driving compartment and exceeding 19 metres in length must be operated in accordance with the 'Class 2 Car Carrier Combination Notice 2011'
- Length laden (LL): Must not exceed 25.0 metres and must be operated in accordance with the 'Class 2 Car Carrier Combination Notice 2011'

Restricted access car carrier comprising prime mover and semi-trailer

In this combination the prime mover is not designed to carry a load over the driving compartment.

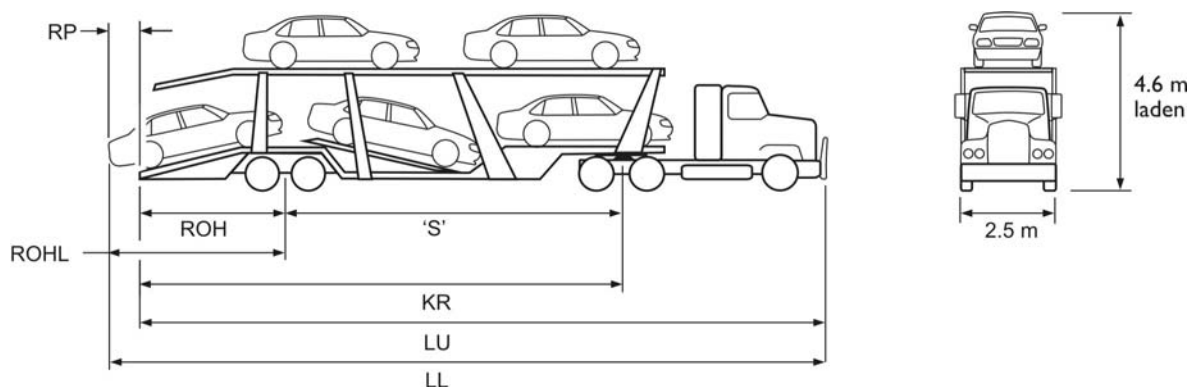

- Rear projection (RP): 1.2 metres rearward of the constructed length of the trailer, included in laden length 'LL'
- Rear overhang (ROH): 60% of 'S' dimension or 3.7 metres, whichever is the lesser
- Rear overhang limit (ROHL): 4.9 metres when laden
- 'S' dimension: 9.5 metres
- Kingpin to rear (KR): May exceed 12.3 metres if the semi-trailer is operating under the 'Class 3 Semi-Trailer Exemption Notice 2012'
- Length unladen (LU): 19.0 metres
- Length laden (LL): 20.2 metres if operating under the 'Class 2 Car Carrier Combination Notice 2011'

Restricted access car carrier comprising prime mover and semi-trailer

In this combination the prime mover is designed to carry a load over the driving compartment.

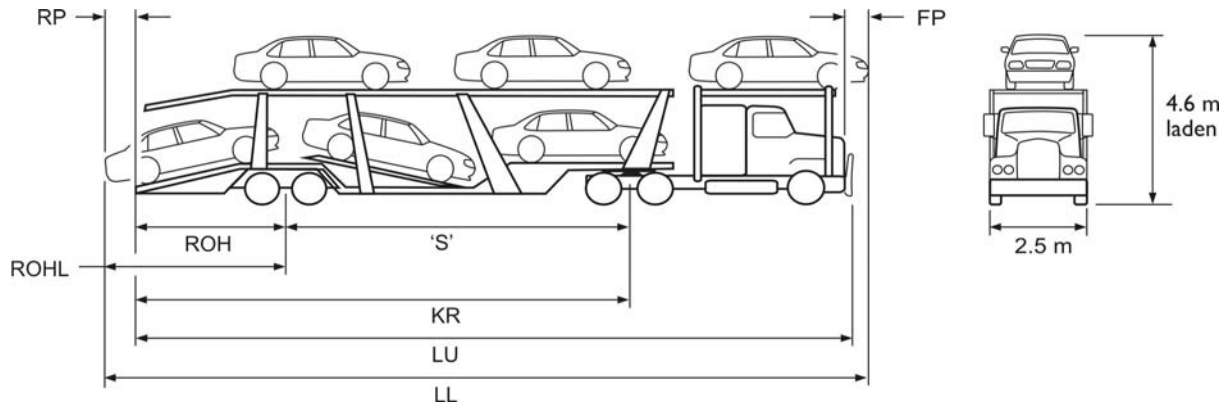

- Rear projection (RP): 1.2 metres rearward of the constructed length of the trailer. Included in laden length 'LL'
- Rear overhang (ROH): 60% of 'S' dimension or 3.7 metres, whichever is the lesser
- Rear overhang limit (ROHL): 4.9 metres when laden
- 'S' dimension: 9.5 metres
- Kingpin to rear (KR): May exceed 12.3 metres if the semi-trailer is operating under the 'Class 3 Semi-Trailer Exemption Notice 2012'
- Forward projection (FP): 1.2 metres in front of headlights, included in laden length 'LL'
- Length unladen (LU): 19.0 metres
- Length laden (LL): 21.4 metres if operating under the 'Class 2 Car Carrier Combination Notice 2011'.

RESTRICTED ACCESS B-DOUBLES

A B-Double is a combination consisting of a prime mover towing two semi-trailers.

In a B-Double built to carry cattle, sheep, pigs or horses, the two semi-trailers must not have more than 18.8 metres of their combined length available for the carriage of animals, with each trailer measured from the inside of the front wall or door to the inside of the rear wall or door, with any intervening partitions disregarded.

Restricted access 19 metre B-Double

A B-Double which does not exceed 19 metres in length, but exceeds a mass of 50 tonnes, may only operate on the routes as set out in the '19 Metre B-Double Mass Limit Notice 2010'.

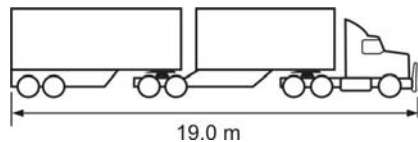

Restricted access 25 metre B-Double

A B-Double which exceeds 19 metres, but does not exceed 25 metres in length, may only operate on the roads and areas as set out in the 'Class 2 B-Double Notice 2010'.

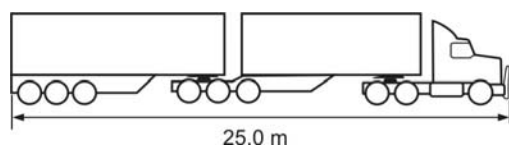

Restricted access 26 metre B-Double

A B-Double may exceed 25 metres, up to a maximum of 26 metres if it operates in accordance with the 'Class 3 26-metre B-Double Exemption Notice 2010'. The distance between the point of articulation at the front of the leading semi-trailer and the rear of the vehicle combination must not exceed 20.6 metres.

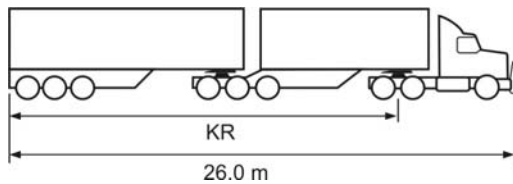

Kingpin to rear (KR): The distance from the centreline of the kingpin of the front trailer to the rear of the combination must not exceed 20.6 metres

Restricted access B-Double towing a converter dolly

A B-Double towing an unladen converter dolly must be operated in accordance with the 'Class 2 Converter Dolly Combination Notice 2011'.

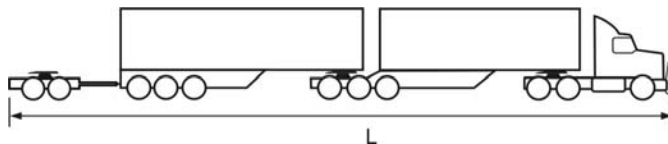

Length (L): Must not exceed 36.5 metres and must operate in accordance with the 'Class 2 Converter Dolly Combination Notice 2011'

Restricted access prime mover and semi-trailer towing a converter dolly

A prime mover and semi-trailer combination towing an unladen converter dolly must be operated in accordance with the 'Class 2 Converter Dolly Combination Notice 2011'.

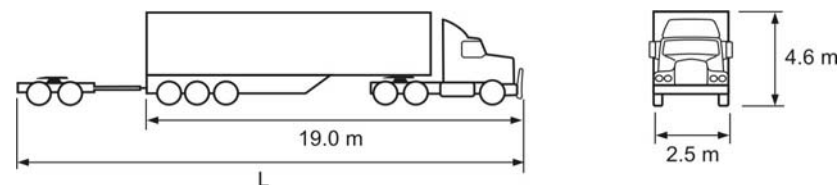

Length (L): Must not exceed 26 metres and must operate in accordance with the 'Class 2 Converter Dolly Combination Notice 2011'

RESTRICTED ACCESS ROAD TRAINS

A road train is a combination, other than a B-Double, consisting of a motor vehicle towing at least two trailers. All road train combinations must operate either under a Notice or a Permit.

Restricted access prime mover, semi-trailer and one dog trailer

Road train combinations consisting of a prime mover, semi-trailer and a dog trailer must not exceed 36.5 metres and may only operate in accordance with the 'Class 2 Road Train Notice 2012'.

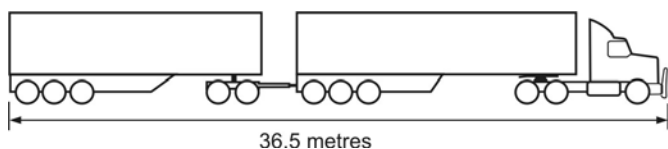

Restricted access rigid vehicle and two dog trailers

Road train combinations consisting of a rigid vehicle and two dog trailers must not exceed 36.5 metres and may only operate in accordance with the 'Class 2 Road Train Notice 2012'.

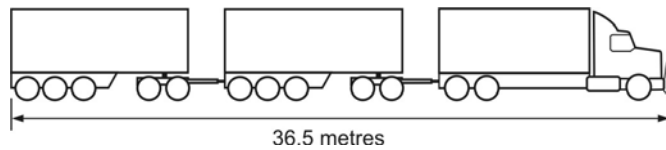

Restricted access prime mover, semi-trailer and two dog trailers

Road train combinations consisting of a prime mover, semi-trailer and two dog trailers must not exceed 53.5 metres and may only operate in accordance with the 'Class 2 Road Train Notice 2012'.

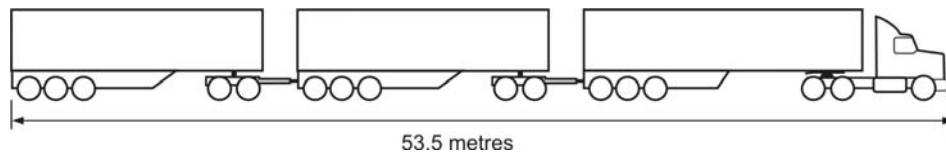

Restricted access AB-Triple

A prime mover and semi-trailer combination connected, by a converter dolly, to two semi-trailers connected by a fifth wheel coupling. This combination may only operate under a specific Permit.

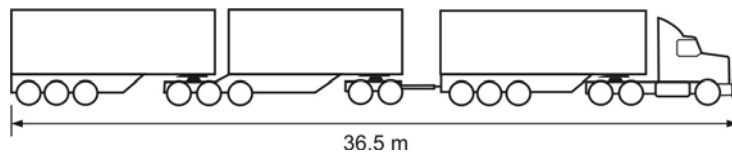

Restricted access B-Triple

A prime mover towing three semi-trailers. This combination may only operate under a specific Permit.

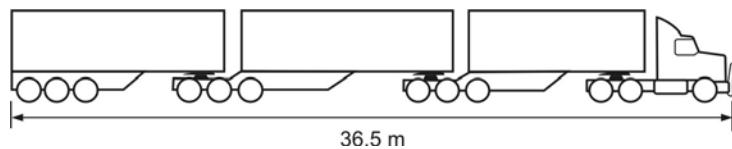

Restricted access BA-Triple

A B-Double combination connected, by a converter dolly, to a semi-trailer,

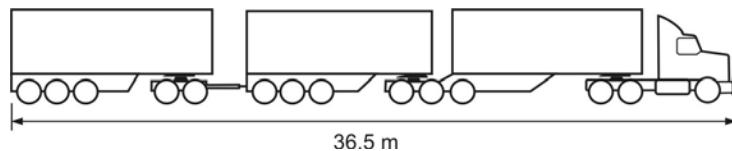

or, a B-Double combination connected to a dog trailer.

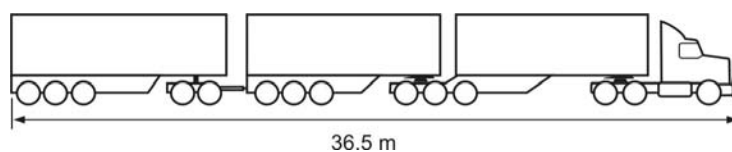

Both of these combinations may only operate under a specific Permit.

6. Other requirements



HEIGHT

The maximum height of a general access vehicle, laden or unladen, is 4.3 metres.

A restricted access vehicle may operate to a maximum limit of 4.6 metres high, but must operate under the '4.6 Metre High Vehicle Notice 2008' as well as any other relevant Notices and/or Permits.

WIDTH

The maximum overall width of a general access vehicle, laden or unladen, is 2.5 metres. It is measured across the body and includes wheel guards, but excludes rear vision mirrors, lights, signalling devices, side mounted lights and tyre pressure monitoring systems.

Any vehicle and its load exceeding 2.5 metres in width is considered to be a restricted access vehicle and may only operate under appropriate RMS approval such as a Notice or Permit.

TURNING CIRCLE

All vehicles other than articulated buses (see page 8), must have a turning circle in either direction such that the extreme outer edge of the tyre track at ground level does not exceed 25 metres in diameter.

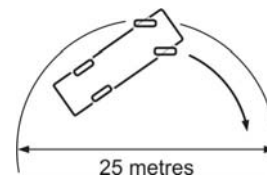

GROUND CLEARANCE

Ground clearance is the minimum distance to the ground from the underside of a vehicle excluding its tyres, wheels, wheel hubs, brake backing plates and flexible mudflaps or mudguards.

All vehicles must conform to the following ground clearance requirements:

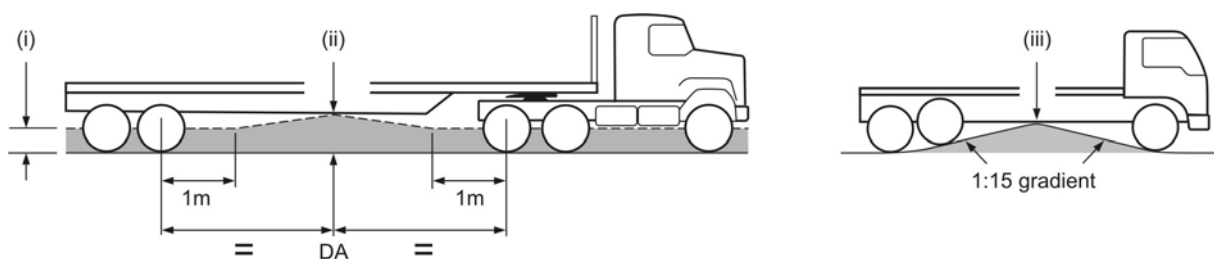

Ground clearance, indicated by the shaded area in above diagram, must:

- (i) be a height of at least 100 mm within one metre of an axle, and
- (ii) be a height of at least one-thirtieth of the distance between centres of adjacent axles, measured at the midpoint between them (DA in above diagram), and
- (iii) allow the vehicle to pass over a peak in the road with a gradient on either side of 1:15, with the wheels of one axle of the vehicle on the slope on one side of the peak and the wheels of the next axle on the slope of the other side. This requirement applies between all axles of a vehicle or combination.

For vehicles manufactured after 16 October 2007, the following requirements also apply:

- The running clearance for a vehicle other than a motor cycle must not be less than 100 mm.
- Where a bus, when fully laden and at normal ride height does not meet (ii) above, a device must be fitted to enable the chassis to be lifted sufficiently to meet the ground clearance requirements.

PROJECTION OF MIRRORS

Except where allowed below, the rear view mirror of a vehicle with a gross vehicle mass (GVM) over 3.5 tonnes must not project more than 150 mm beyond the widest part of the vehicle or combination on either side (P in diagram at right).

However, the rear vision mirrors may project up to 230 mm beyond the widest part of the vehicle or combination if they can fold to project not more than 150 mm beyond the widest part on either side.

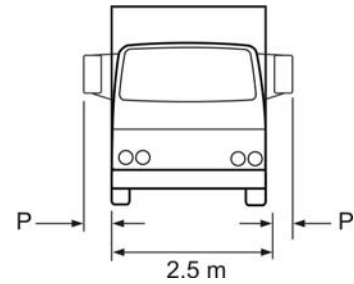

For vehicles manufactured after 15 August 2006, rear vision mirrors that comply with Australian Design Rule (ADR)14/02 *Rear Vision Mirrors* by complying with ECE R46*, may protrude up to 250 mm beyond the widest part of the vehicle, where the lower edge of the mirror is less than 2 metres above the ground.

*United Nations Economic Commission for Europe Regulation No. 46.

PROJECTING LOADS OR EQUIPMENT – LIGHT VEHICLES

The following dimension limits for projecting loads and equipment apply to any light vehicle or vehicle/trailer combination having a GVM or GCM of 4.5 tonnes or less, other than a motorcycle or sidecar combination.

For motorcycle dimension limits see VSI No. 28 *Guidelines for modifications to motorcycles*.

For information on carrying bicycles on a bicycle rack see VSI 10 *Carrying bicycles on motor vehicles*.

Light vehicle up to 9.5 metres in length

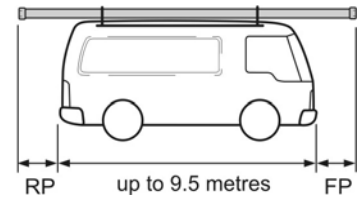
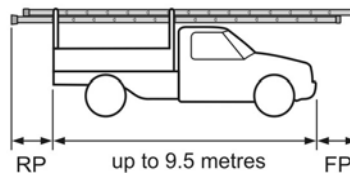
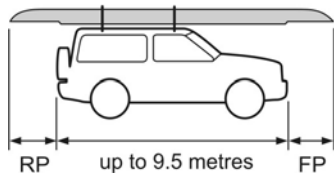

- Rear projection (RP): 1.2 metres (may exceed 1.2 metres under certain conditions – see 'Warning devices for projecting loads or equipment - light vehicles' on page 17)
- Forward projection (FP): 1.2 metres in front of the headlights. Included in overall length
- Side projection (not shown): 150 mm beyond extreme outer edge of either side of vehicle, excluding mirrors.

Light vehicle more than 9.5 metres in length

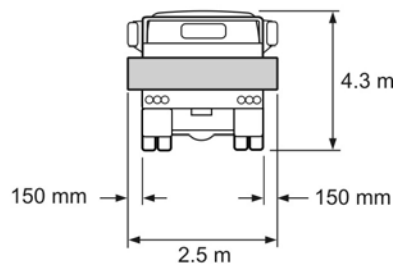
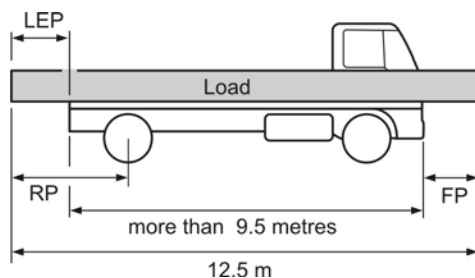

- Rear projection (RP): 4 metres, measured from the rear overhang line
- Forward projection (FP): 1.2 metres in front of the headlights. Included in overall length
- Load or equipment projection (LEP): If greater than 1.2 metres it is recommended that warning devices be fitted – see 'Warning devices for projecting loads or equipment - light vehicles' on page 17.

Light vehicle and trailer combination

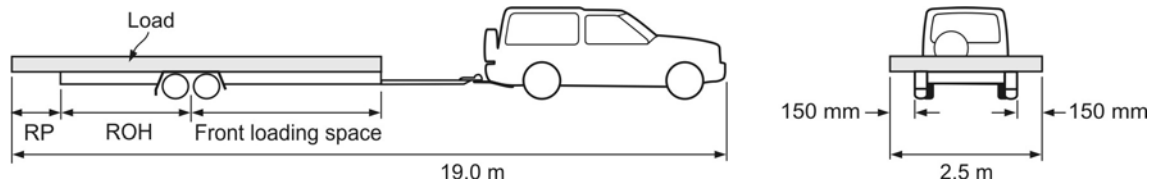

Rear projection (RP): 1.2 metres (may exceed 1.2 metres under certain conditions – see ‘Warning devices for projecting loads or equipment - light vehicles’ below)

Rear overhang (ROH): no more than the length of the front loading space or 3.7 metres, whichever is the lesser.

If the trailer in this combination is loaded with rowing boats, see VSI No. 43 *Transporting rowing boats* for more information.

If the trailer in this combination is loaded with a small yacht, see VSI No. 62 *Transporting yachts on trailers* for more information.

Warning devices for projecting loads or equipment – light vehicles

A light vehicle, or a light vehicle and trailer combination, may have a rear projection exceeding 1.2 metres if the overall length of the vehicle or combination, together with the loading or equipment on it, is within the relevant limits fixed by the Regulation i.e.

- 12.5 metres in the case of a light vehicle
- 19.0 metres in the case of a light vehicle and trailer combination.

If the rear projection is greater than 1.2 metres, the rear of the load or equipment must have attached a brightly coloured flag or piece of material not less than 300 mm square. In addition to the flag, when travelling at night or in adverse weather conditions that restrict visibility, a red light or at least two red reflectors must be attached:

- the red light needs to be seen for 200 metres
- the reflectors need to be capable of projecting a red reflection of light.

These requirements also apply to any load or equipment that projects less than 1.2 metres if it projects in such a way that it is not readily visible to a person following immediately behind the vehicle.

PROJECTING LOADS – HEAVY VEHICLES

The following dimension limits for projecting loads apply to:

- any vehicle having a GVM exceeding 4.5 tonnes
- any combination having a GCM exceeding 4.5 tonnes
- any combination that includes a vehicle with a GVM exceeding 4.5 tonnes.

Projecting loads must not exceed these limits unless the vehicle operates under a Notice or Permit.

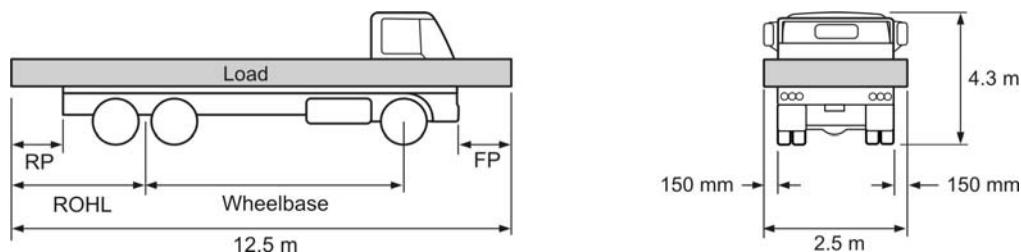

Rear overhang limit (ROHL): 60% of the wheelbase or 3.7 metres, whichever is the lesser

Forward projection (FP): 1.2 metres in front of the headlights, included in overall length

Rear projection (RP): 1.2 metres (may exceed 1.2 metres under certain conditions – see ‘Warning devices for projecting loads - heavy vehicles’ on page 18)

If a vehicle and trailer combination in this category is carrying a small yacht on the trailer, see VSI No. 62 *Transporting yachts on trailers* for more information.

Warning devices for projecting loads – heavy vehicles

Rear projection may exceed 1.2 metres if the overall length of the vehicle or combination, together with the loading or equipment on it, is within the relevant limits fixed by the Regulation i.e.

- 12.5 metres in the case of a heavy vehicle
- 19.0 metres in the case of a heavy vehicle and trailer combination.

In either case, if the rear projection of the load is greater than 1.2 metres, the rear of the load must carry a warning signal that is:

- in daytime, a brightly coloured flag or piece of material with each side not less than 300 mm long
- at night, a red light that can be seen for 200 metres.

It is recommended that these requirements also apply to any load or equipment that projects less than 1.2 metres if it projects in such a way that it is not readily visible to a person following immediately behind the vehicle.

REAR OVERHANG

Rear overhang (ROH) is the distance between the ROH line and the rear of the vehicle.

The rear overhang line is determined as follows:

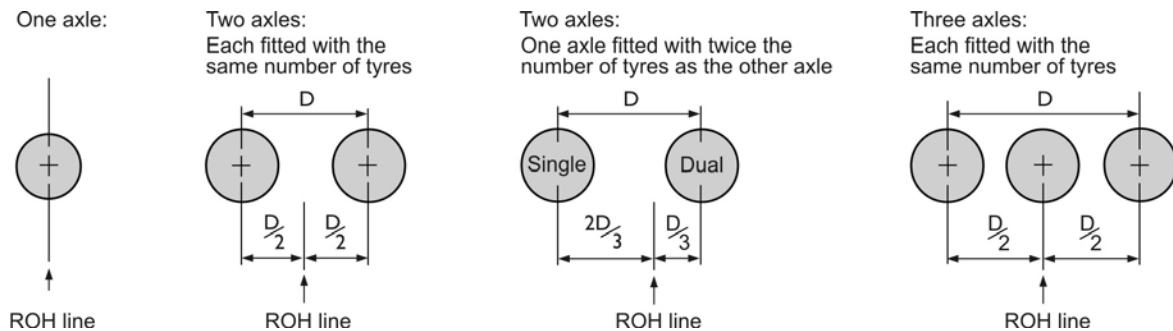

Retractable axle/s

A vehicle fitted with a retractable axle must, in all configurations, comply with all relevant requirements of rear overhang.

Steerable axle/s

A steerable axle in a rear axle group is ignored for the purpose of determining rear overhang, unless all axles in the group are steerable. If all axles in a group are steerable, the rear overhang line is determined in the same way as for a fixed axle group. Wheels that are not linked to the vehicle's steering mechanism, such as swivelling caster type wheels, are not considered steerable, and any axle they are attached to is not a steerable axle.

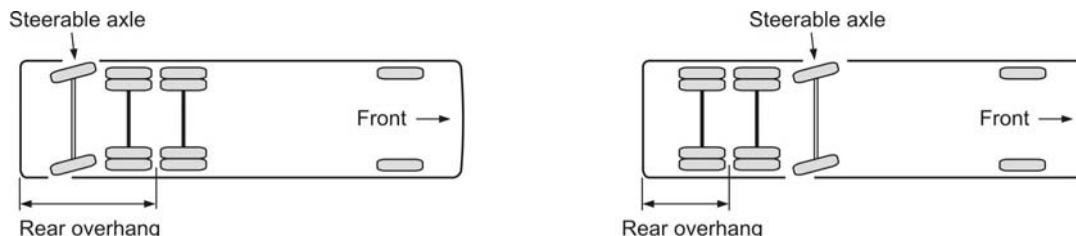

AXLES AND AXLE GROUPS

An axle group is a single axle group, tandem axle group, tri-axle group, quad axle group or twinsteer axle group.

Rigid vehicles or prime movers are supported by two axle groups only. The wheels of the front axle group must be connected to a steering mechanism for the vehicle.

Axle groups on vehicles first registered in NSW after 28 April 1978 must be within the dimension limits shown in the following diagrams. If an axle group on any vehicle is modified after 28 April 1978 it must, after modification, also conform to these requirements.

Single axle group

A group of two or more axles in which the distance 'D' between centrelines of outermost axles is less than one metre.

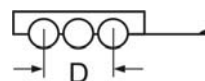

Tandem axle group

A group of 2 or more axles in which the distance 'D' between centrelines of the outermost axles is at least one metre, but not more than two metres.

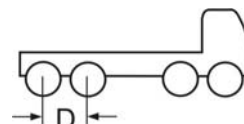

Tri-axle group

A group of three or more axles in which the distance 'D' between centrelines of the outermost axles is more than two metres, but not more than 3.2 metres.

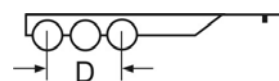

Quad-axle group

A group of four axles in which the distance 'D' between centrelines of the outermost axles is more than 3.2 metres, but not more than 4.9 metres.

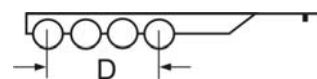

Twinsteer axle group

A group of two steerable axles with single tyres fitted to a motor vehicle in which the distance 'D' between centrelines of the axles is at least one metre, but not more than two metres.

For a vehicle with a twinsteer axle group the front axle must be used when determining the wheelbase.

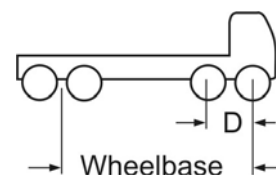

Load-sharing axle groups

For the protection of roads, tandem, tri or quad axle groups must be provided with an effective system of load-sharing. A retractable axle must also be load-sharing with other axles in the group when the retractable axle is down. A twinsteer axle group may be load-sharing or non load-sharing, however lower mass limits apply if it is non load-sharing. For further information on mass and load-sharing requirements refer to:

- RMS brochure *Heavy Vehicle Mass, Loading and Access*
- the Regulation
- the MLAs.

7. Agricultural vehicles

The maximum dimension limits for general access agricultural vehicles or combinations are:

	Height	Width	Length
Single vehicle	4.3 metres	2.5 metres	12.5 metres
Vehicle combination	4.3 metres	2.5 metres	19.0 metres

An agricultural vehicle or combination that exceeds any of the above dimensions is a restricted access vehicle or combination and may only operate under a Notice or Permit. Notices are available for download from the RMS website www.rms.nsw.gov.au. For further information contact RMS Permits Section – see page 20 for contact details.

8. Glossary

Converter dolly means a pig trailer with a fifth wheel coupling, designed to convert a semi-trailer into a dog trailer.

Gross combination mass (GCM) is the value specified by the manufacturer of a vehicle as being the sum of its GVM plus the maximum loaded mass of any trailer (or motor vehicle) that it can tow in combination.

Gross vehicle mass (GVM) of a vehicle means the maximum loaded mass of the vehicle:

- as specified by the vehicle's manufacturer, or
- as specified by RMS if:
 - the manufacturer has not specified a maximum loaded mass, or
 - the manufacturer cannot be identified, or
 - the vehicle has been modified to the extent that the manufacturer's specification is no longer appropriate.

Plant means a motor vehicle that is built to operate as a machine or implement and is not capable of carrying goods or passenger by road.

- Examples of plant vehicles – an agricultural machine, backhoe, bulldozer, excavator, forklift, front-end loader, grader, tractor.
- Examples of vehicles that are not plant vehicles – a truck-mounted crane or truck-mounted drilling rig.

Retractable axle means an axle that can be raised so that the tyres on the axle do not touch the ground.

Running clearance is the distance from the surface on which an unladen vehicle is standing to the lowest point on the vehicle excluding unsprung mass.

'S' dimension is the distance between the point of articulation at the front of a semi-trailer and the rear overhang line.

Special purpose vehicle (SPV) means a motor vehicle, other than a tow truck or an agricultural vehicle, built for a purpose other than carrying a load, except for water in the case of concrete pumps and fire trucks.

Steerable axle means an axle whose wheels are connected to a steering mechanism for the vehicle. An axle with castor wheels that are not linked to the steering mechanism is not considered a steerable axle.

Trailer means a vehicle without motive power constructed to be drawn behind a motor vehicle.

FURTHER INFORMATION

Roads and Maritime Services

W www.rms.nsw.gov.au

- VSI No. 10 *Carrying bicycles on motor vehicles*
- VSI No. 28 *Guidelines for modifications to motorcycles*
- VSI No. 43 *Transporting rowing boats*
- VSI No. 46 *Registration of non-conforming special purpose vehicles*
- VSI No. 62 *Transporting yachts on trailers*
- RMS brochure *Heavy Vehicle Mass, Loading and Access*

Roads and Maritime Services Technical Enquiries

PO Box 1120, Parramatta NSW 2124

E tech-enq@rms.nsw.gov.au | T 1300 137 302 | F 02 8837 0037

- Vehicle construction and registration requirements in NSW

Roads and Maritime Services Special Permits Unit

PO Box 94, Glen Innes NSW 2370

E spu@rms.nsw.gov.au | T 1300 656 371 | F 1300 361 570



- Overdimension and/or overmass permits

New South Wales Government Contact Centre

W www.legislation.nsw.gov.au | T 133 679

- Road Transport (Vehicle Registration) Regulation 2007
- Road Transport (Mass, Loading and Access) Regulation 2005

Classifying Commercial Vehicles

LIGHT TRUCKS—up to 10,000 lbs. GVW	
<p>Light trucks are of the pickup or light van type. It is very unusual—although possible—for vehicles of these types to have a GVW over 10,000 lbs. Please note that the GVW on step vans can vary between 8,000 lbs. and 17,000 lbs., depending upon the size.</p>	
<p>Used to transport the contractor's tools and equipment to job site and principally parked at the job location for the majority of the working day. No other use.</p> <p>Business class is Service.</p>	
<p>This is operated by a department store for the delivery of goods purchased by its customers to their homes.</p> <p>The business use class is Retail.</p>	

MEDIUM TRUCKS—10,001 lbs. to 20,000 lbs. GVW	
<p>The manufacturer usually refers to vehicles in this weight category as "1½ tons" to "2 tons."</p> <p>Please take care in verifying GVW since some vehicles that have a manufacturers GVW between 10,000 and 20,000 lbs. often show a weight under 10,000 lbs on the vehicle registration and other vehicles though having a GVW in excess of 20,000 lbs, are registered under 20,000 lbs.</p>	
<p>Sign contractor's truck used to bring signs, equipment and tools to job site; principally parked at the job location for most of the working day. No pickup or delivery of goods to others.</p> <p>Business use class is Service.</p>	

Door-to-door delivery of milk by creamery.

Business use class is *Retail*.

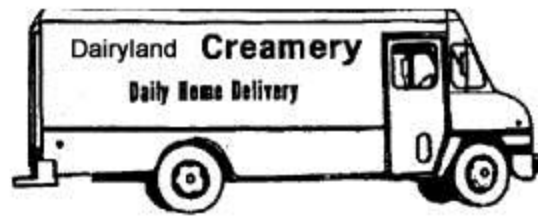

HEAVY TRUCKS—20,001 lbs. to 45,000 lbs. GVW

Many trucks other than light trucks will fall into this category. The manufacturer usually refers to these trucks as "2½ tons to 4½ tons" and in some cases up to "5 tons."

Although many of the 2½-ton trucks will have a gross *registered* weight 20,000 lbs. or less, the GVW given by the manufacturer must still be used.

Concrete forms being brought to job site by building contractor; vehicle principally parked at the job location for most of the working day.

Business use class is *Service*.

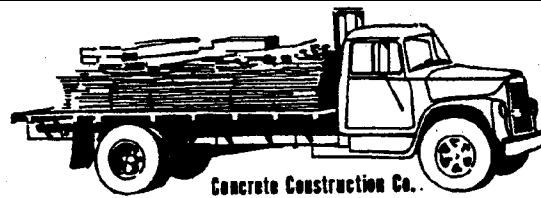

Delivery of furniture to retail customers by store.

Business use class is *Retail*.



EXTRA HEAVY TRUCKS—over 45,000 lbs. GVW

There are no separate business use classifications for vehicles falling into this weight category. All trucks in this category carry the same class and factor.

Many trucks falling into this category will be the very large dump trucks and the larger mix-in-transit trucks. Vehicles in this weight range will have a nominal rating of 4½ tons and above.

Mix-in-transit truck

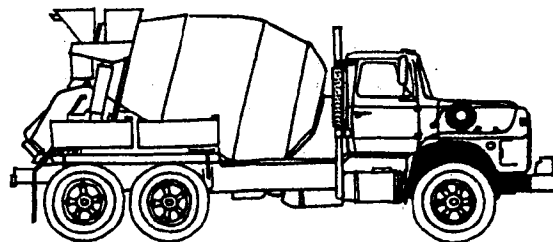

Dump truck

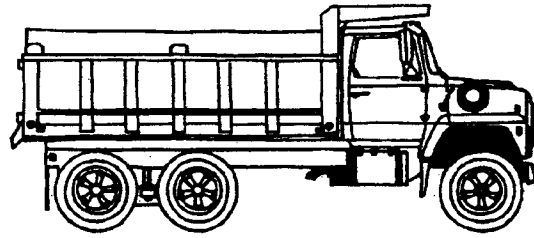

HEAVY TRUCK TRACTORS—up to 45,000 lbs. GCW

Tractors in this weight category are the smaller tractors and trucks equipped with a fifth wheel for hauling semi-trailers or mobile homes (known as toters). Strange as it may seem, this category includes those pickups that are equipped to pull semi-trailers used for the transportation of auto, fiberglass boats, etc, commonly referred to as hot shots.

Tractor hauling mobile homes

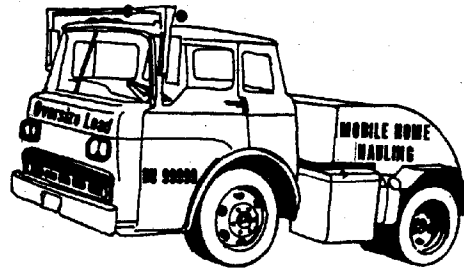

Note 1: Very few tractors of this size exist. They are limited to tractors used for hauling very light loads.

Note 2: When classifying tractors, please take care not to confuse GVW with GCW. GVW is given on tractors for registration purposes only and will always be less than the needed GCW.

EXTRA HEAVY TRUCK TRACTORS—over 45,000 lbs. GCW

The majority of tractors fall into this category. It does not matter if the tractor is single rear axle or dual rear axle. If the GCW is over 45,000 lbs., it is classified under this category.

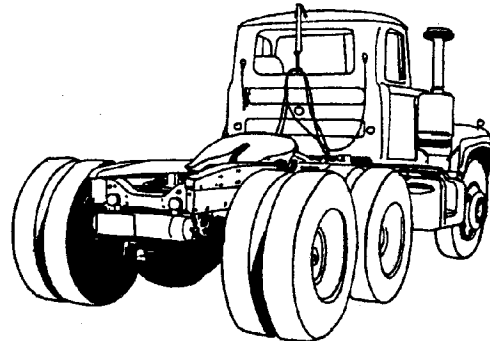

Note 1: Although no business use classifications apply to extra heavy truck tractors, secondary classifications do.

Note 2: When classifying truck tractors, please take care not to confuse GVW with GCW. GVW is given for registration purposes only and will always be less than the needed GCW.

TRAILER TYPES (3 types)

1. Service or utility trailer

Trailers or semi-trailers, with a capacity of 2,000 lbs. or less. There is no premium charge for BI and PD.

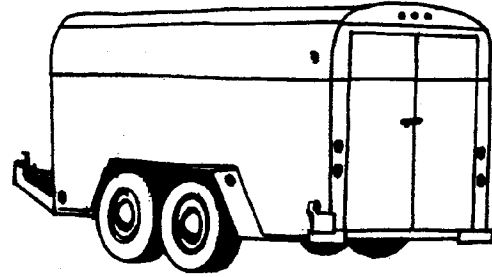

2. Semi-trailer

Trailers with a load capacity of 2,000 lbs. with wheels at rear only, equipped with a fifth wheel coupling device and hauled behind tractors.

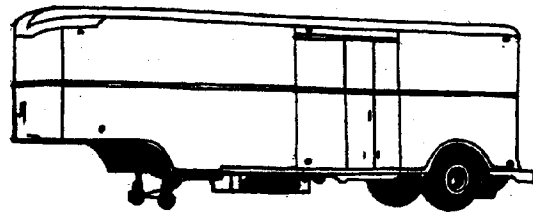

3. Trailers: All other types of trailers including Tilt Bed Trailers with load capacities over 2,000 lbs.

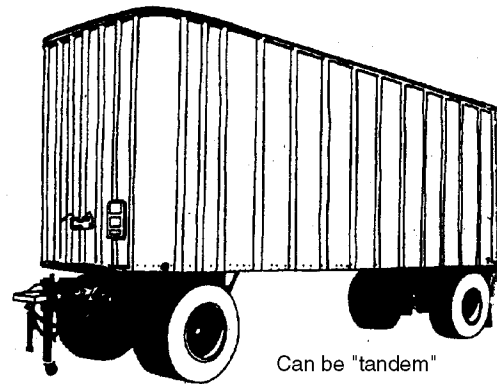

Note: Secondary classifications and factors do not apply to trailers of any type except for dump trailers. For dump trailers secondary designator "OT" applies.