

# DISPLAY DEVICES & RECORDERS



# Recorder

**Recorder is a device which records electrical and non electrical quantities as a function of time.**

Current and voltages can be recorded directly, while the non electrical quantities are recorded indirectly.

□ ***Types of recorders:***

1. Analog recorders
2. Digital recorders

# Types of Analog recorders

**Analog recorders are further divided in to three types:**

## 1. Graphic recorder

- ▣ strip – chart recorder
- ▣ circular chart recorder
- ▣ X – Y recorder

## 2. Oscillographic recorder

## 3. Magnetic – tape recorder

- ▣ Direct recorder
- ▣ F. M. recorder
- ▣ pulse modulation recorder

# X – Y RECORDER

- X-Y recorder is an instrument which gives a graphic record of the relationship between two variables.
- X-Y recorder is one which records the variation of one physical quantity against another physical quantity.
- It is used to measure *voltage, current, frequency, power factors etc....*

- X-Y recorder consists of a pair of servosystems, driving a recording pen in two axis on stationary paper chart.
- Attenuators are used to bring the input signal to the levels acceptable by the recorder.
- Two input signal are applied to the two channels of X input & Y input.

# X-Y Recorders figure

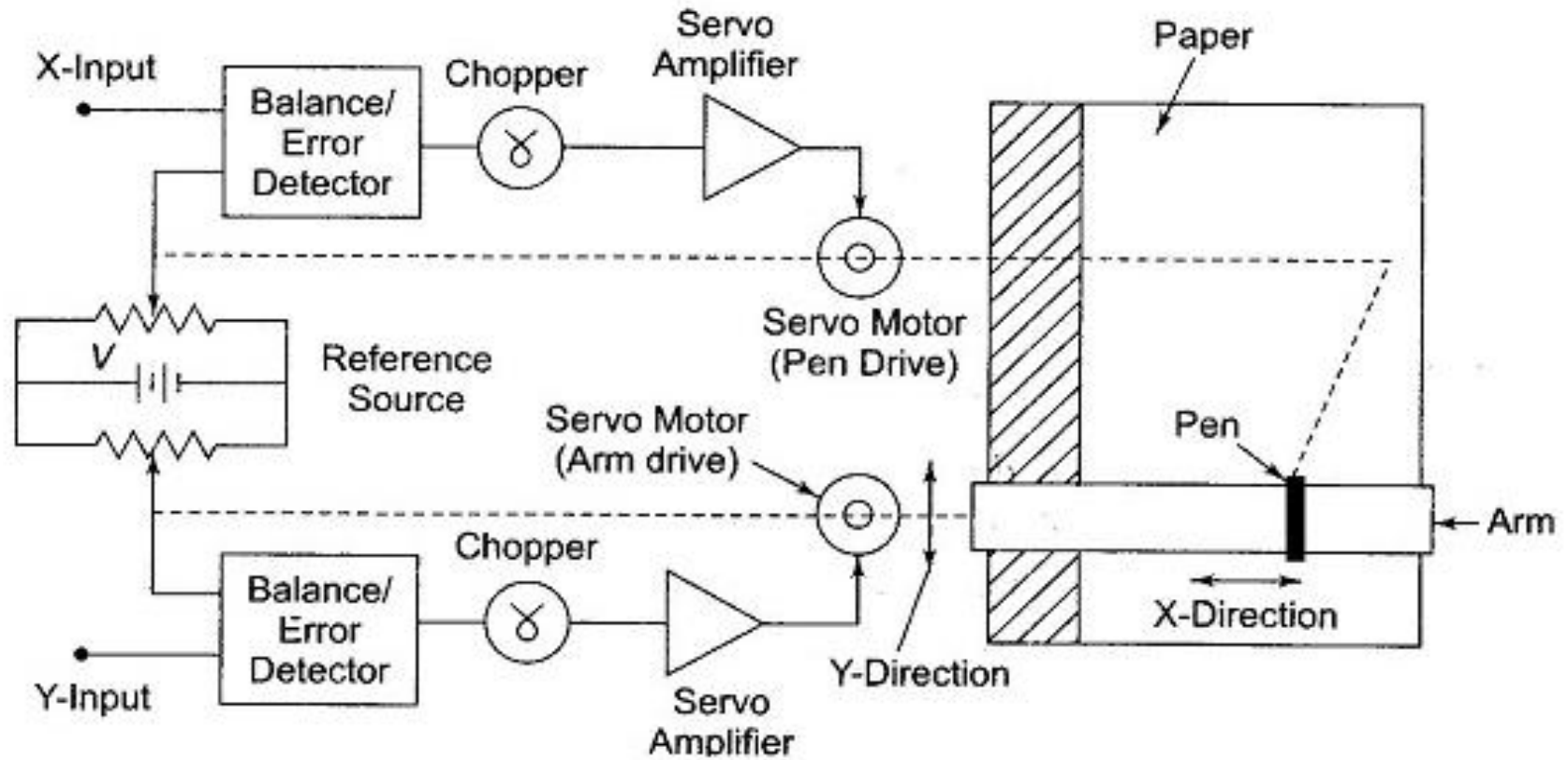

- 
- Some X—Y recorders provides x and y input ranges which are continuously variable between 0.25 mV/cm and 10 V/cm, with an accuracy of  $\pm 0.1\%$  of the full scale.
  - Zero offset adjustments are also provided.
  - The dynamic performance of X—Y recorders is specified by their slewing rate and acceleration.
  - A very high speed X—Y recorder, capable of recording a signal up to 10 Hz at an amplitude of 2 cm peak to peak, would have a slewing rate of 97 cm/s and a peak acceleration of 7620 cm/s.

- An XY Recorder Working may have a sensitivity of  $10 \mu\text{V}/\text{mm}$ , a slewing speed of  $1.5 \text{ ms}$  and a frequency response of about  $6 \text{ Hz}$  for both the axis.
- The chart size is about  $250 \times 180 \text{ mm}$ . The accuracy of X—Y recorder is about  $\pm 0.3\%$ .

# Applications

- The X-Y recorders are used in laboratories and industrial process control. Some of the uses are listed.
- Speed – Torque characteristics of motor.
- Lift – Drag wind tunnel test.
- Regulation curves of power supplies.
- Plotting stress – strain curves.
- Hysteresis curves.

# STRIP CHART RECORDER

- It records one or more variables with respect to time. It is a X-t recorder.
- A strip chart recorder consists of:
  1. A long roll of graph paper moving vertically.
  2. A system for driving a paper at some selected speed.
    - ▣ A speed selector switch is generally provided.
    - ▣ chart speed of 1-100 m/s are usually used.
  3. A stylus driving system which moves the stylus in a near exact replica or analog of the quantity being recorded.

- 
- A range selector switch is used so that input to the recorder drive system is within the acceptable level.
  
  - Paper drive system:
    - The paper system should move the paper at a uniform speed.
      - A spring would may be used but in most of the recorder a synchronous motor is used for driving the paper.

- **Marking Mechanism:** There are many types of mechanism used for making marks on the paper. The most commonly used ones are:
  - **Marking with ink filled stylus:**
    - The stylus is filled with ink by gravity or capillary actions.
    - This requires that the pointer shall support an ink reservoir and a pen, or capillary connection between the pen and a pen reservoir.
    - In general red ink is used but other colours are available and in instrumentation display a colour code can be adopted.

## □ **Marking with headed stylus.**

- Some recorders use a heated stylus which writes on a special paper.
- This method overcomes the difficulties encountered in ink writing systems.

## □ **Chopper Bar.**

- If a chart made from a pressure sensitive paper is used a simple recording process is possible.
- A V-shaped pointer is passed under a chopper bar which presses the pen into the paper once per second thus making a series on the special paper.
- In fact this system is not purely continuous and hence is suitable for recording some varying quantities.

## □ Electric stylus marking:

- This method employs a paper with a special coating which is sensitive to current.
- When current is conducted from the stylus to the paper, a trace appears on the paper.
- It is clear that the electric stylus marking method has a wide range of marking speeds, has low stylus friction and a long stylus life.
- The disadvantage is that the cost of paper is very high.

# Tracing system:

- There are two types of tracing system used for producing graphic representation.

## 1. Curvilinear system.

- In the curvilinear system, the stylus is mounted on a central pivot and moves through an arc which allows a full width chart marking
- If the stylus makes a full range recording, the line drawn across the chart will be curved and the time intervals will be along the curved segments

## 2. **Rectilinear system.**

- This system produces a straight line across the width of the chart.
- Hence the stylus is actuated by a drive cord over pulleys to produce the forward and reverse motion as determined by the drive mechanism.
- The stylus may be actuated by a self-balancing potentiometer system, a photoelectric deflection system, a photoelectric potentiometer system, or a bridge balance system.
- This system is usually used with thermal or electric wiring.

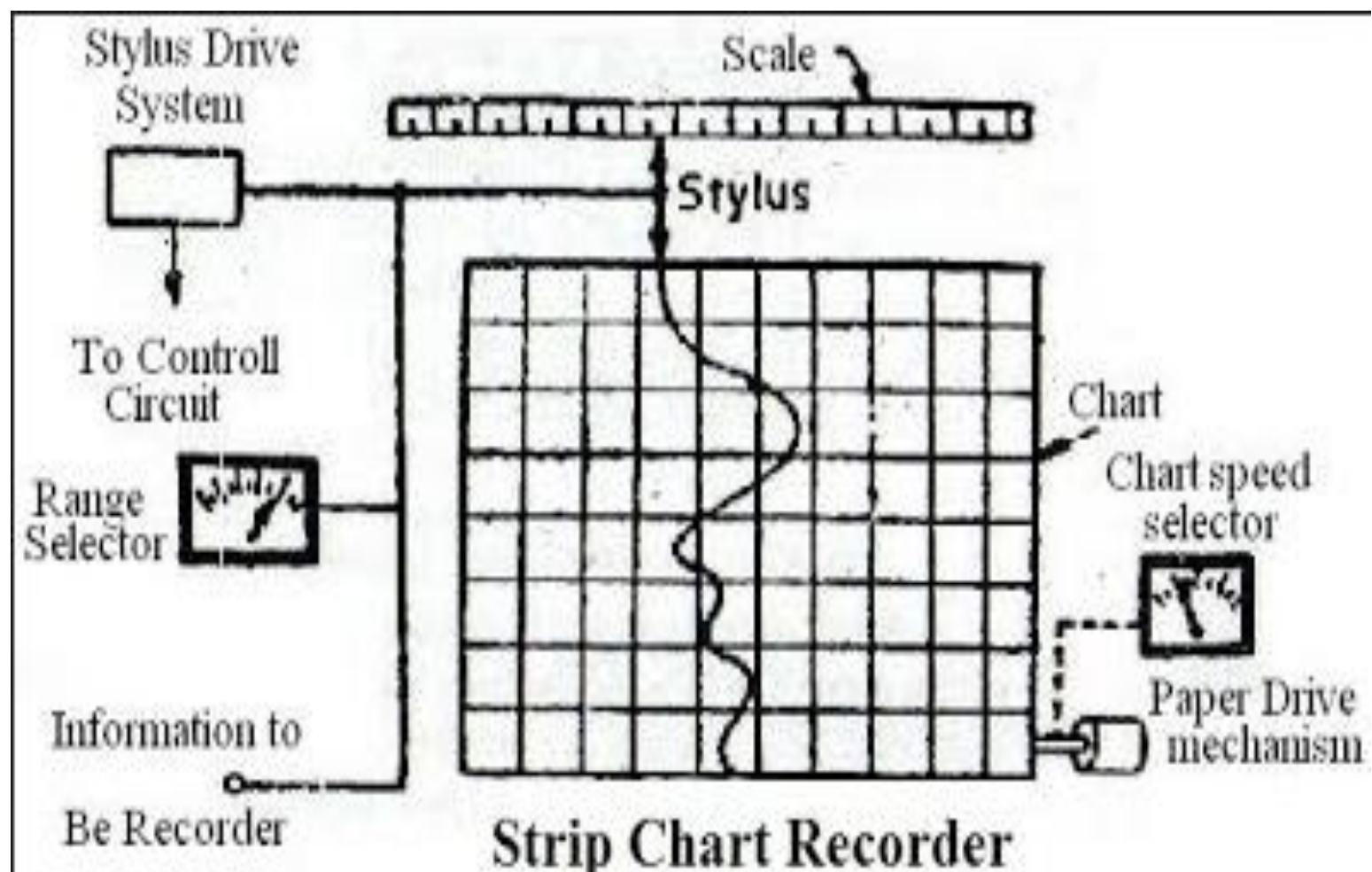

# Galvanometer Type Recorder

- **Principle of operation:-** this type of recorder operates on the deflection principle.
- The deflection is produced by a galvanometer which produced **a torque on account of a current passing through its coil.**
- This current is proportional to the quantity being measured.

# Galvanometer Type Recorder

- A Galvanometer type recorder is shown in fig. the pointer is equipped with a recording pen mechanism (stylus).
- As the current flows through the coil. It deflects.
- The greater the amplitude of the incoming signal, the greater is the deflection.
- The chart is driven at a constant speed by a clockwork mechanism or an electric motor.
- When the pointer comes to rest on account of controlling torque exerted by springs, the stylus also comes to rest.
- Thus the value of the physical quantity is recorded.

# Galvanometer Type Recorder

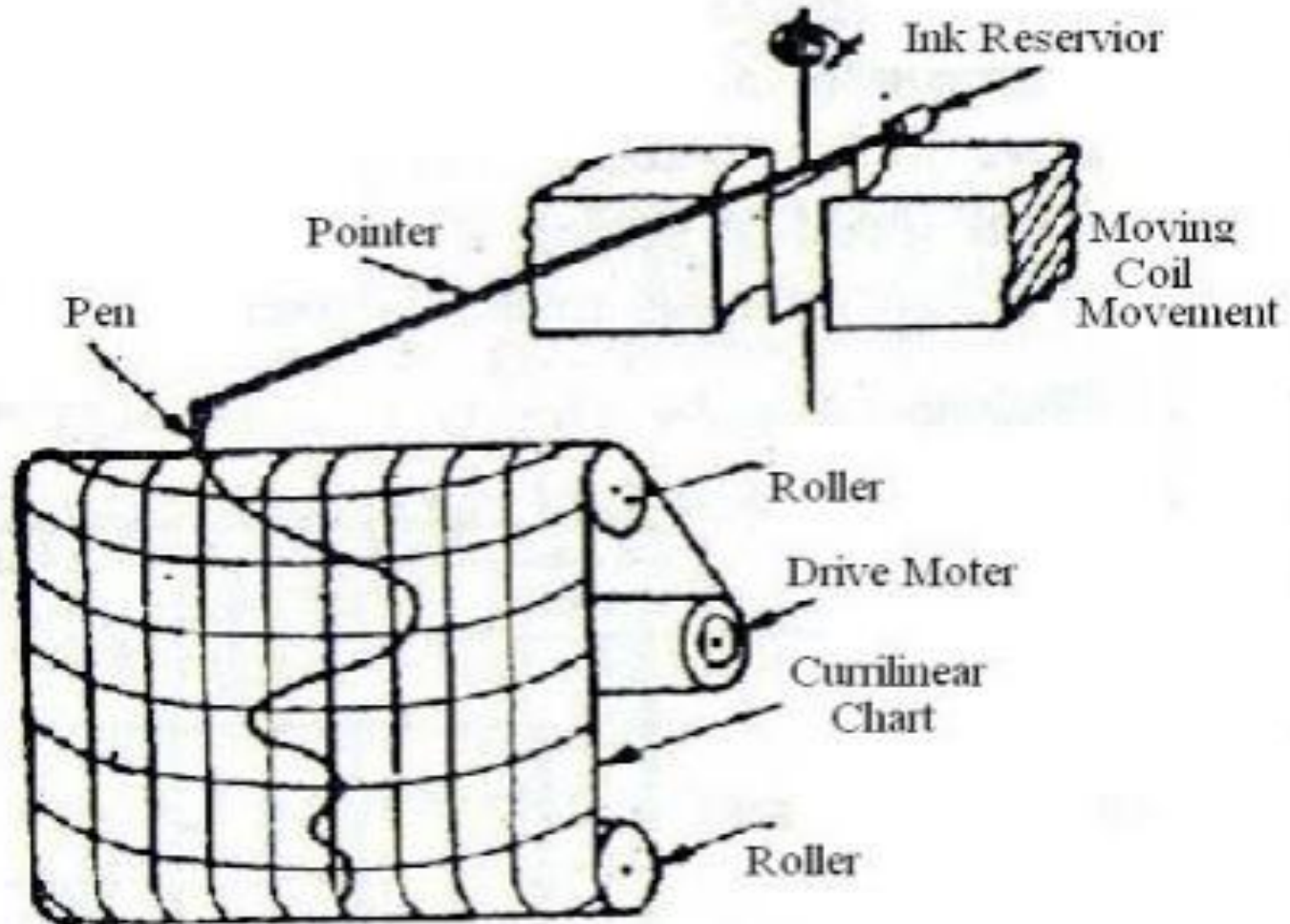

# Magnetic Tape Recorder

- A magnetic tape recorder is used to record data which can be retrieved and reproduced in electrical form again.
- This recorder can record signals of high frequency.

# Description of Magnetic Tape Recorders

- The magnetic tape is made of a thin sheet of tough plastic material; one side of it is coated with a magnetic material (iron oxide).
- The plastic base is usually polyvinyl chloride (PVC).
- Recording head, reproducing head and tape transport mechanism are also present.

# Construction

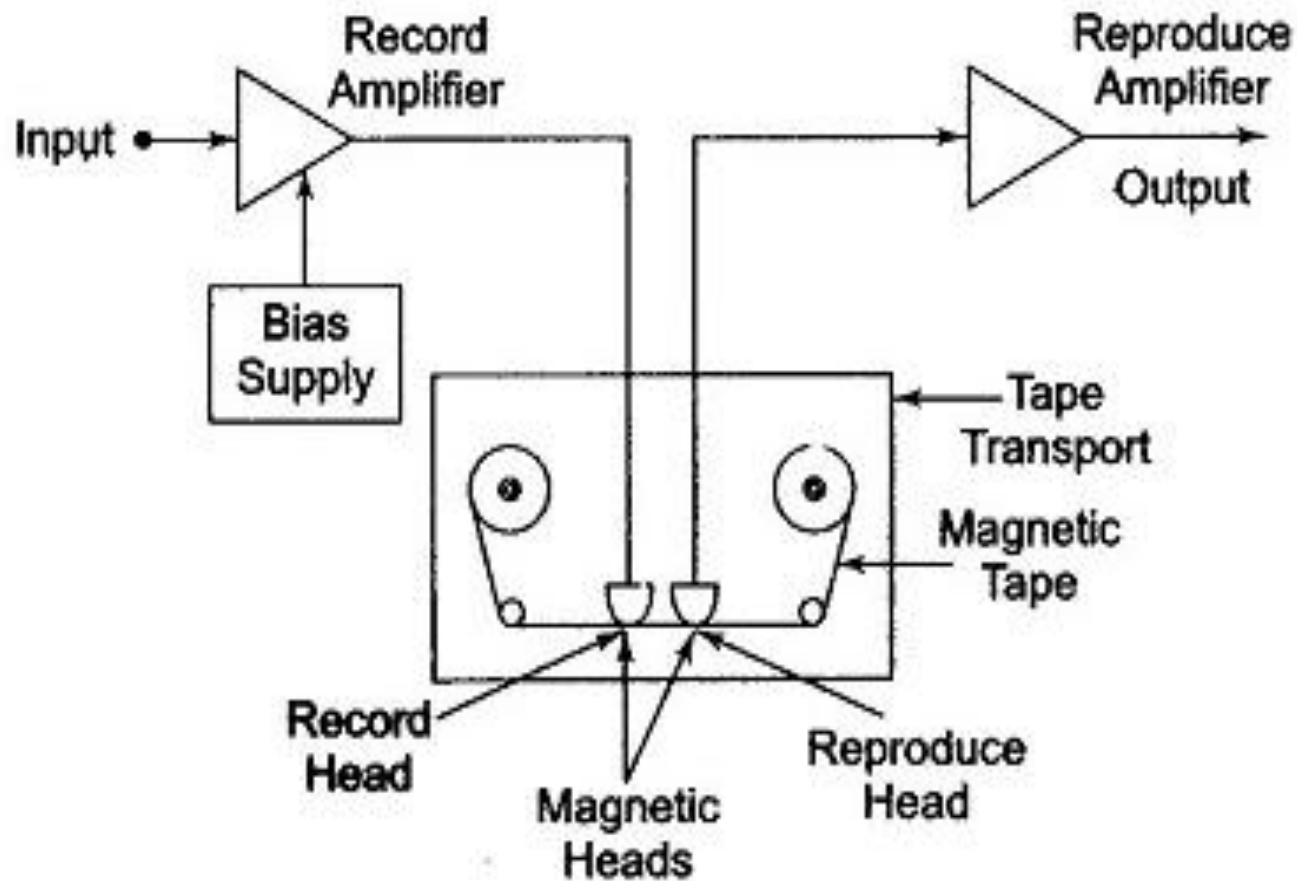

# Operation of Magnetic Tape

## Recorders:

- The **recording head** consists of **core, coil and a fine air gap of about 10 micrometer**.
- The **coil current creates a flux**, which passes through the air gap to the magnetic tape and **magnetizes the iron oxide particles as they pass the air gap**.
- So the actual recording takes place at the trailing edge of the gap.

# Reproducing head

- The reproducing head is similar to that of a recording head in appearance.
- The magnetic tape is passes over a reproducing head, **thereby resulting in an output voltage proportional to the magnetic flux in the tape, across the coil of the reproducing head.**
- Thus **the magnetic pattern in the tape is detected and converted back into original electrical signal.**

# Tape transport mechanism

- The tape transport mechanism moves the tape below the head at constant speed without any strain, distortion or wear.
- The mechanism be such as to guide the tape passed by the magnetic heads with **great precision, maintain proper tension and have sufficient tape to magnetic head contact.**

# Advantages of Magnetic Tape Recorders:

- Wide frequency range.
- Low distortion.
- Immediate availability of the signal in its initial electrical form as no time is lost in processing.
- The possibility of erase and reuse of the tape.
- Possibility of playing back or reproducing of the recorded signal as many times as required without loss .

# Applications of Magnetic Tape Recorders:

---

- Data recording and analysis on missiles, aircraft and satellites.
- Communications and spying.
- Recording of stress, vibration and analysis of noise.

# Display Device

- A **display device** is an output device for presentation of information in visual or tactile form (the latter used for example in tactile electronic displays for blind people).

# Electronic displays

## Segment displays

- Some displays can show only digits or alphanumeric characters.
- They are called **segment displays**, because they are composed of several segments that switch on and off to give appearance.
- The segments are usually single LEDs or liquid crystals.
- They are mostly used in digital watches and pocket calculators. There are of several types

# Display devices

- The display system is the final link between the measuring process and the user.
- Display devices are used in instrumentation systems to provide instantaneous but nonpermanent communication of information between a process or system and a human observer.
- Data can be presented to the observer in either an analog or a digital form

- In measurement there are two types of **Displays—analogue and digital.**
- **Analogue displays use a needle and calibrated scale to indicate values.**
- Analogue displays have a pointer which moves over a graduated scale.
- They can be difficult to read because of the need to work out the value of the smallest scale division.

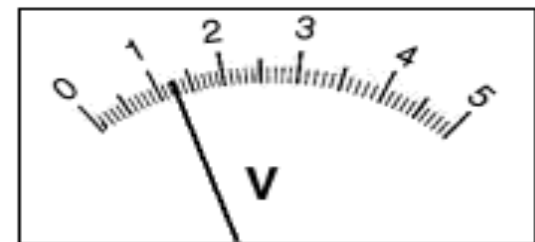

# Digital displays

- **Digital displays show the measured value as digits and they are more accurate than analogue.**
- They are easier to use because they give specific value.
- Digital displays are often capable of displaying smaller values in easy understandable way.





Generally there are different types of displays but the most commonly used are:

- Cathode ray tube (CRT)
- LED displays
- Liquid crystal displays(LCD)
- Cold cathode display or Nixies
- Liquid vapour display (LVD)

# Cathode ray tube

- The Cathode Ray Tube was invented by the German physicist Karl Ferdinand Braun in 1897.
- Today its is used in computer monitors, TV sets and oscilloscope tubes.
- CRTs have advanced employing many different techniques to increase image precision and quality
- Today's CRT displays are much more advanced than those of a decade ago, they are much simpler than other display technologies.

# Main components of CRT



The CRT is a display screen which produces images in the form of the video signal.

**It is a type of vacuum tube which displays images when the electron beam through electron guns are strikes on the phosphorescent surface.**

In other Words, the CRT generates the beams, accelerates it at high velocity and deflect it for creating the images on the phosphorous screen so that the beam becomes visible.

# Working of CRT

- The working of CRT depends on the movement of electrons beams.
- The electron guns generate sharply focused electrons which are accelerated at high voltage.
- This high-velocity electron beam when strikes on the fluorescent screen creates luminous spot

# Construction

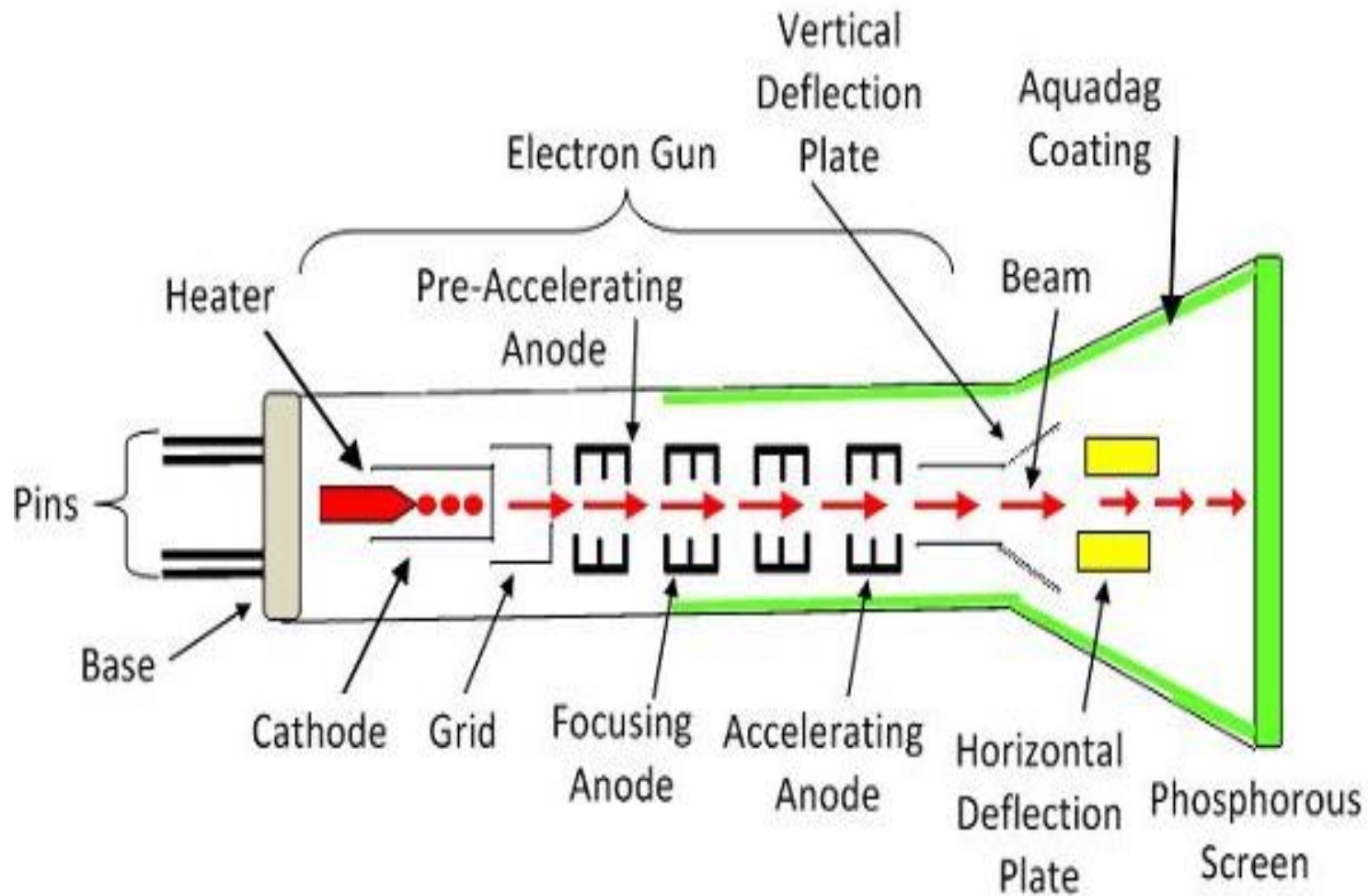

# Working

- After exiting from the electron gun, the beam passes through the pairs of electrostatic deflection plate.
- These plates deflected the beams when the voltage applied across it.
- The one pair of plate moves the beam upward and the second pair of plate moves the beam from one side to another.
- The horizontal and vertical movement of the electron are independent of each other, and hence the electron beam positioned anywhere on the screen.
- The working parts of a CRT are enclosed in a vacuum glass envelope so that the emitted electron can easily move freely from one end of the tube to the other.

# The screen

- The screen, which is at the front of the CRT, is what actually displays the images.
- When the electron fired from the gun strikes the screen and hits an atom in the phosphor, it transfers its energy to an electron in the phosphor

# Advantages of CRT

---

- Wide viewing angle
- Very simple implementation
- High resolution technology
- Excellent color fidelity
- Long life and reliability

# Disadvantages of CRT

---

- ❑ High power consumption
- ❑ So Big and Bulky
- ❑ Needs cooling system
- ❑ Interference

# LCD (Liquid Crystal Displays)

- The most output device Like a TV mobiles & computer makes (display) .
- Most computers use a (LCD) , light-emitting diode (LED), and gas plasma or other image projection technology.
- Monitors using LCD technologies are beginning to replace CRT.

# LCD History

- Liquid Crystals will play an important role in modern technology .
- **The LCD is defined as the diode that uses small cells and the ionised gases for the production of images.**
- The LCD works on the **modulating property of light.**
- **The light modulation is the technique of sending and receiving the signal through the light.**
- It is normally used for seven segmental display.

# Basic structure of an LCD

- A liquid crystal cell consists of a thin layer (about 10  $\mu$ m) of a liquid crystal sandwiched between two glass sheets with transparent electrodes deposited on their inside faces.

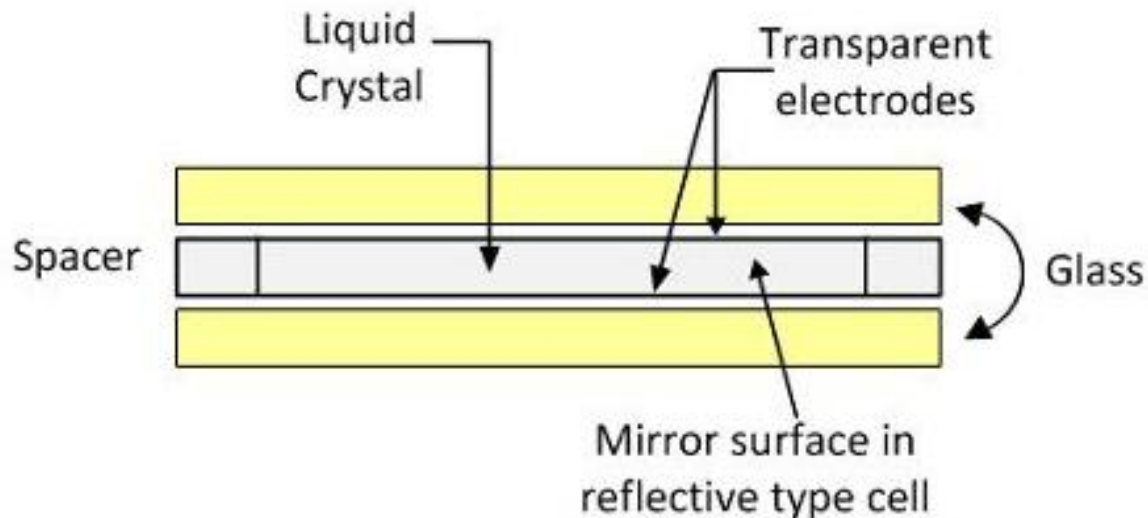

# Basic structure of an LCD

- With both glass sheets transparent, the cell is known as **transmittive type cell**.
- When one glass is transparent and the other has a reflective coating, the cell is called **reflective type**.
- The LCD does not produce any illumination of its own.
- It, in fact, depends entirely on illumination falling on it from an external source for its visual effect

# Working Principle of LCD

- The working principle of the LCD is of two types. They are the dynamic scattering type and the field effects type.

## Dynamic Scattering

- When the potential carrier flows through the light, the molecular alignment of the liquid crystal disrupts, and they produce disturbances.
- The liquid becomes transparent when they are not active.
- But when they are active their molecules turbulence causes scattered of light in all directions, and their cell appears bright. This type of scattering is known as **the dynamic scattering**.

# Field Effect Type

- The construction of liquid crystals is similar to that of the dynamic scattering types the only difference is that in field effect type LCD the two thin polarising optical fibres are placed inside the each glass sheet.
- .

- The field affects type LCD uses the nematic material which twisted the unenergised light passing through the cell.
- The nematic type material means the liquid crystals in which the molecules are arranged in parallel but not in a well-defined plane.
- The light after passing through the nematic material passing through the optical filters and appears bright.
- When the cell has energized no twisting of light occurs, and the cell appears dull.

# Advantages of LCDs

- Physical Size
- Compact and Lightweight
- Space saving
- Can be mounted on a wall or panel
- Until recently, was only used on notebook computers



- Less Power Consumption and Radiation Emission
- LCD consumes fewer watts than a CRT.
- LCD will use an average 30 watts compared to 120 watts for the CRT.
- Can reduce electric bill by 40-85%.
- Does not emit Radiation
- Not subject to Electromagnetic Interference

- Viewing
  - Cause less eyestrain
- Does not flicker or glare
  - Color
    - Most are capable of displaying unlimited colors.
- Resolution
- Multiple video Resolutions.

# Disadvantages of LCDs

---

- It has Narrow viewing angle
- Do not Refresh the pixels very QUICKLY
- LCD Display is that their images can be difficult To see in bright light.

# Light-Emitting Diode Displays

- Light-emitting diode (LED) displays involve **single crystal phosphor materials**.
- LED displays are highly versatile and well suited to a variety of measurement applications.
- Advantages of LED displays include high reliability and graceful degrades; individual LED elements can fail without affecting overall display performance

- 
- LEDs are rugged, for operation in harsh environments, and they are more tolerant of temperature extremes than other technologies.
  - LEDs demonstrate better viewing angles than LCDs, and excellent brightness for visibility in sunlight.

# Seven Segment Displays

- A seven-segment display can be used to display the decimal numbers 0-9 and some alpha characters.
- A common anode seven-segment display works.
- A common cathode seven-segment display works.
- the resistor should be properly selected for a seven-segment display.



# Segment Identification

- A Seven-Segment Display (SSD) is simply a figure eight grouping of LEDs {some include a decimal point (DP)}.
- Each Segment is labeled (a) thru (g).
- SSDs are available in two configurations
  - Common Cathode (all LED cathodes are connected)
  - Common Anode (all LED anodes are connected)

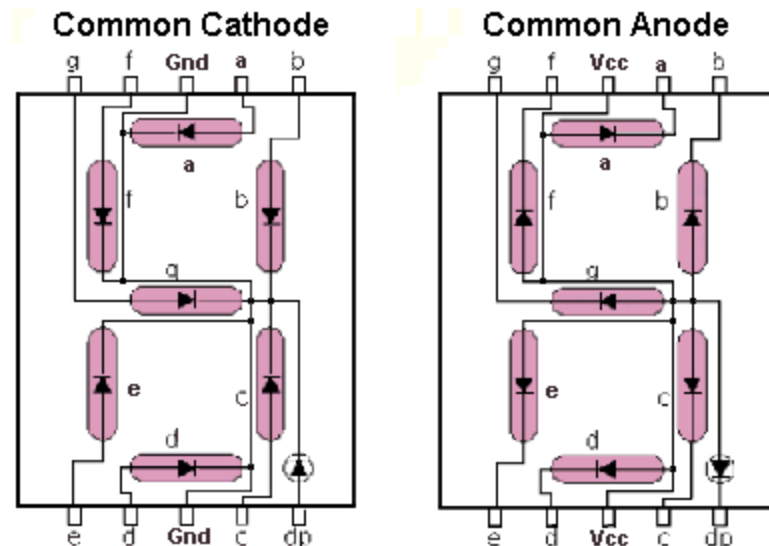
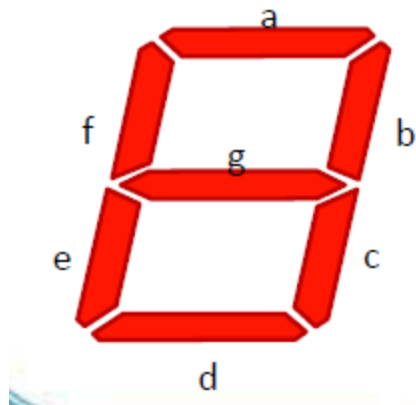

# SSD Display Possibilities

Decimal Digits 0-9



Select Alpha Characters

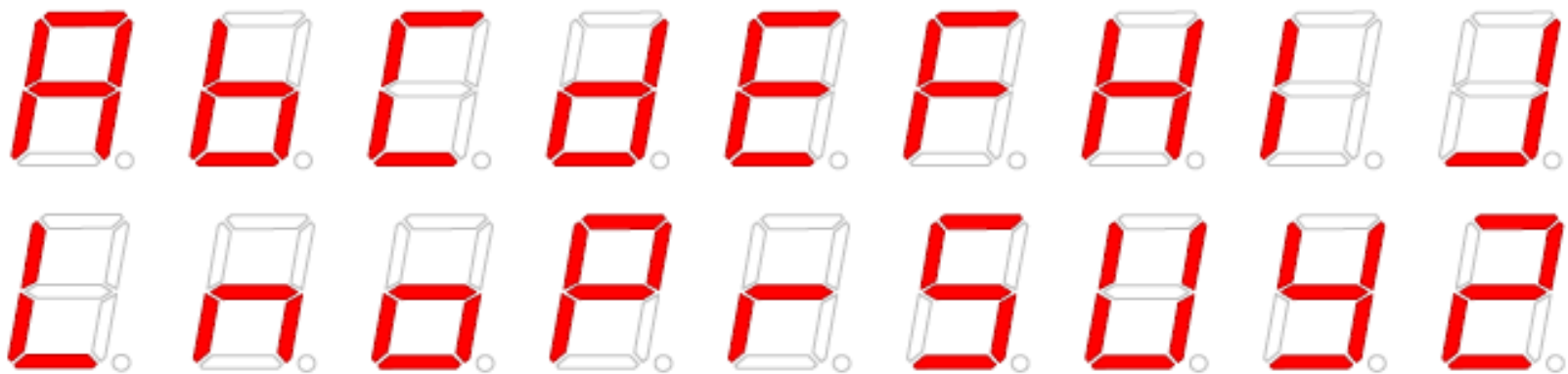

Simple Messages



# Basic LED Operations

## To Turn an LED ON . . .

- The ANODE must be at a higher voltage potential than the CATHODE.
- The amount of current flowing through the LED will determine the brightness of the LED.
- The amount of current is controlled by a series resistor.

# Resistor Values for SSD

- The resistor value determines the amount of current that is flowing through the LED in the SSD.
- This is why they are sometimes called current limiting resistors .
- The amount of current determines how luminous the LED will be.
- If the resistor is too large, the current will be too small and the LED will not be visible.
- If the resistor is too small, the current will be too large and the LED will be damaged.

# Merits of LED displays

- Energy efficient
- Long Lifetime - 50,000 hours or more if properly engineered.
- Not affected by cold temperatures
- Controllable - LED's can be controlled for brightness and color

# Disadvantage of LED

- ❑ LEDs are currently more expensive.
- ❑ LED performance largely depends on correctly engineering the fixture to manage the heat generated by the LED, which causes deterioration of the LED chip itself.
- ❑ LEDs must be supplied with the correct voltage and current at a constant flow.
- ❑ This requires some electronics expertise to design the electronic drivers.

# Cold cathode display

- A **Nixie** or **cold cathode display**, is an electronic device for displaying numerals or other information using glow discharge.
- Inside a Nixie tube “**The glass tube contains a wire-mesh anode and multiple cathodes, shaped like numerals or other symbols**”.
- Applying power to one cathode surrounds it with an orange glow discharge.
- The tube is filled with a gas at low pressure, usually mostly neon and often a little mercury or argon, in a Penning mixture

# Cold cathode display

- The most common form of **Nixie tube has ten cathodes in the shapes of the numerals 0 to 9** (and occasionally a decimal point or two), but there are also types that show various letters, signs and symbols.
- Because the numbers and other characters are arranged one behind another, each character appears at a different depth, giving Nixie based displays a distinct appearance.

# Cold cathode display

- Each cathode can be made to glow in the characteristic neon red-orange color by applying about 170 volts DC at a few milliamperes between a cathode and the anode.
- The current limiting is normally implemented as an anode resistor of a few tens of thousands of ohms.
- Nixies exhibit negative resistance and will maintain their glow at typically 20 V to 30 V below the strike voltage.
- Some color variation can be observed between types, caused by differences in the gas mixtures used.

# Cold cathode display

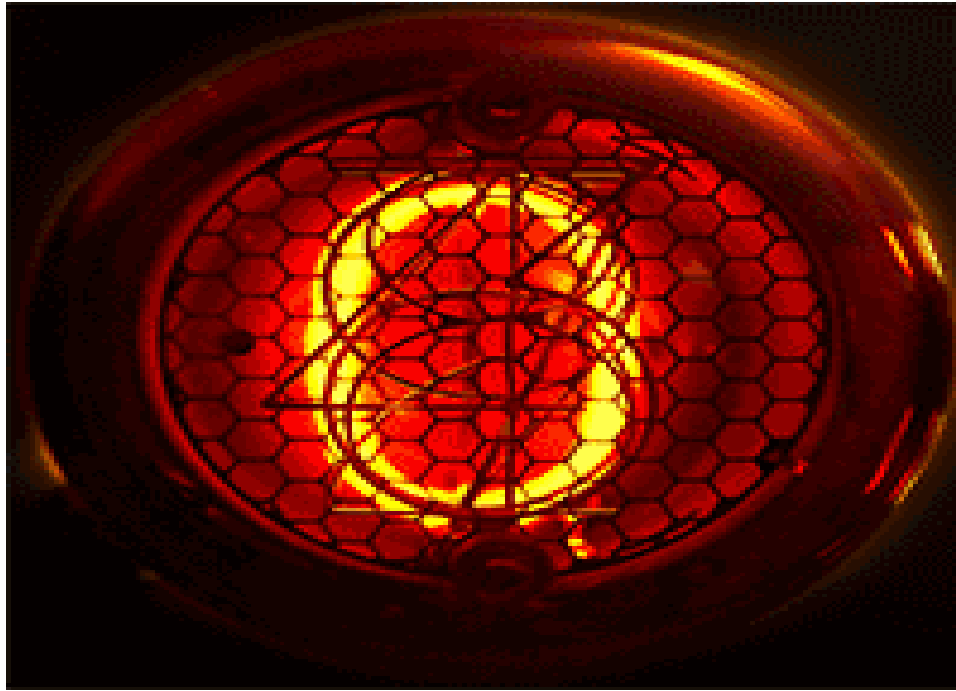

# Liquid vapor display

- **Liquid Vapor Display (LVD)** is a type of display system and is especially considered in economical display technologies.

The figure shows the structure of a typical LVD cell.

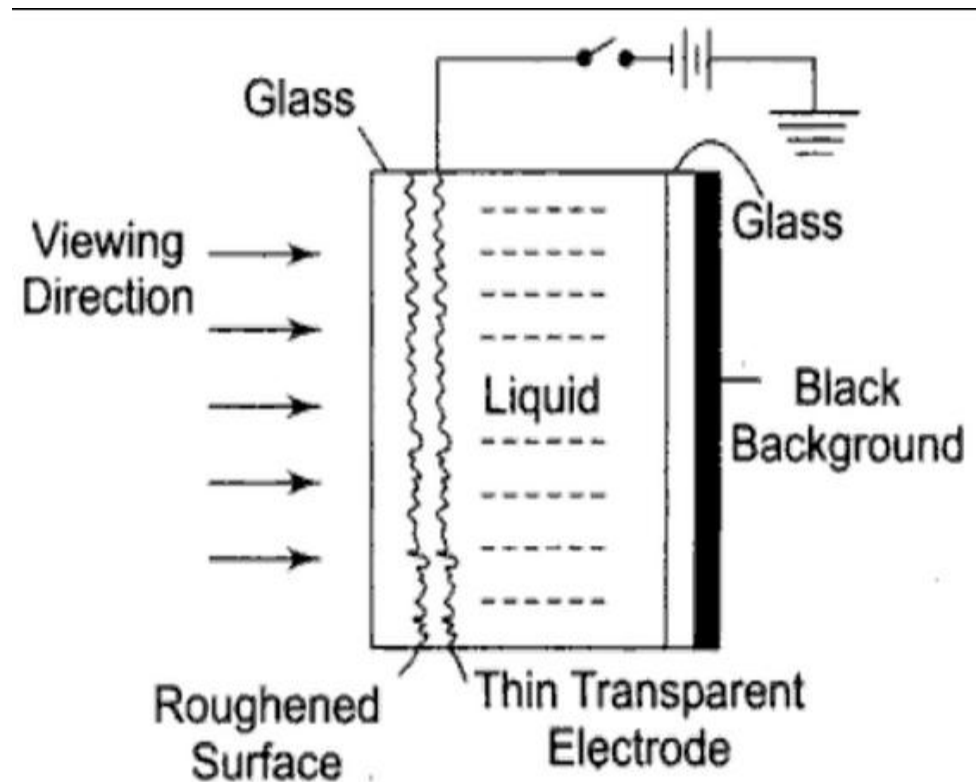

# Liquid vapor display

- It consists of a transparent volatile liquid encased between two glass plates and side spacers.
- The rear glass plate has a black background and the front glass surface in contact with the liquid is roughened, so that the liquid wets it,
  - ▣ i.e. in its simplest form, an LVD consists of a roughened glass surface wet with a transparent volatile liquid of the same refractive index as that of the glass.
- The rear surface is blackened.
- The transparent electrode is heated by using a voltage drive, which is the basis of display function.

# Liquid vapor display

- In the OFF condition of display with no voltage applied across the transparent electrode, the viewer sees the black background through the front transparent glass electrode and the liquid.
- To achieve the ON condition of the display, a voltage is applied to the transparent electrode.
- This causes sufficient heat in electrode, which evaporates the liquid in contact with it, and a combination of vapor film and vapor bubbles is formed around the roughened glass surface.
- As the refractive index of vapor is approximately 1, there is a discontinuity established at the interface between the front glass plate and the liquid, this causes the incoming light to scatter before reaching the black background.
- Thus making it a simple display device.

# Liquid vapor display

- The organic liquid selected for LVD should have the following features:
  1. Refractive index close to that of the glass plate.
  2. Minimum energy for vaporizing the liquid in contact with the roughened surface.

# Data Acquisition System

A data acquisition system consists of many components that are integrated to:

- Sense physical variables (use of transducers).
- Condition the electrical signal to make it readable by an A/D board.
- Convert the signal into a digital format acceptable by a computer.
- Process, analyze, store, and display the acquired data with the help of software .

# Need

- Data acquisition systems interface between the real world of physical parameters, which are analog, and the artificial world of digital computation and control.
- DAQ are used widely because they are low cost, accurate, and relatively simple to implement.
- Data acquisition systems are capable of measuring hundreds of variables simultaneously.
- They are now used by most engineers and scientists for laboratory research, industrial control, test, and measurement of input and output data to and from a computer.
- Industries that presently employ such automatic systems include steel making, food processing, paper production, oil refining, chemical manufacturing, textile production, cement

# Objective of Data Acquisition System

- The data acquisition system must acquire the necessary data at correct speed & at the correct time.
- It must use all the data efficiently to inform the operator about the state of the plant.
- It must monitor the operation of complete plant .
- It must provide effective human communication system which helps in identifying the problem areas.
- It must be able to collect, summaries & store data properly for
- diagnosis.
- It must be able to compute unit performance indices using real time communication

# Block Diagram of Data Acquisition System

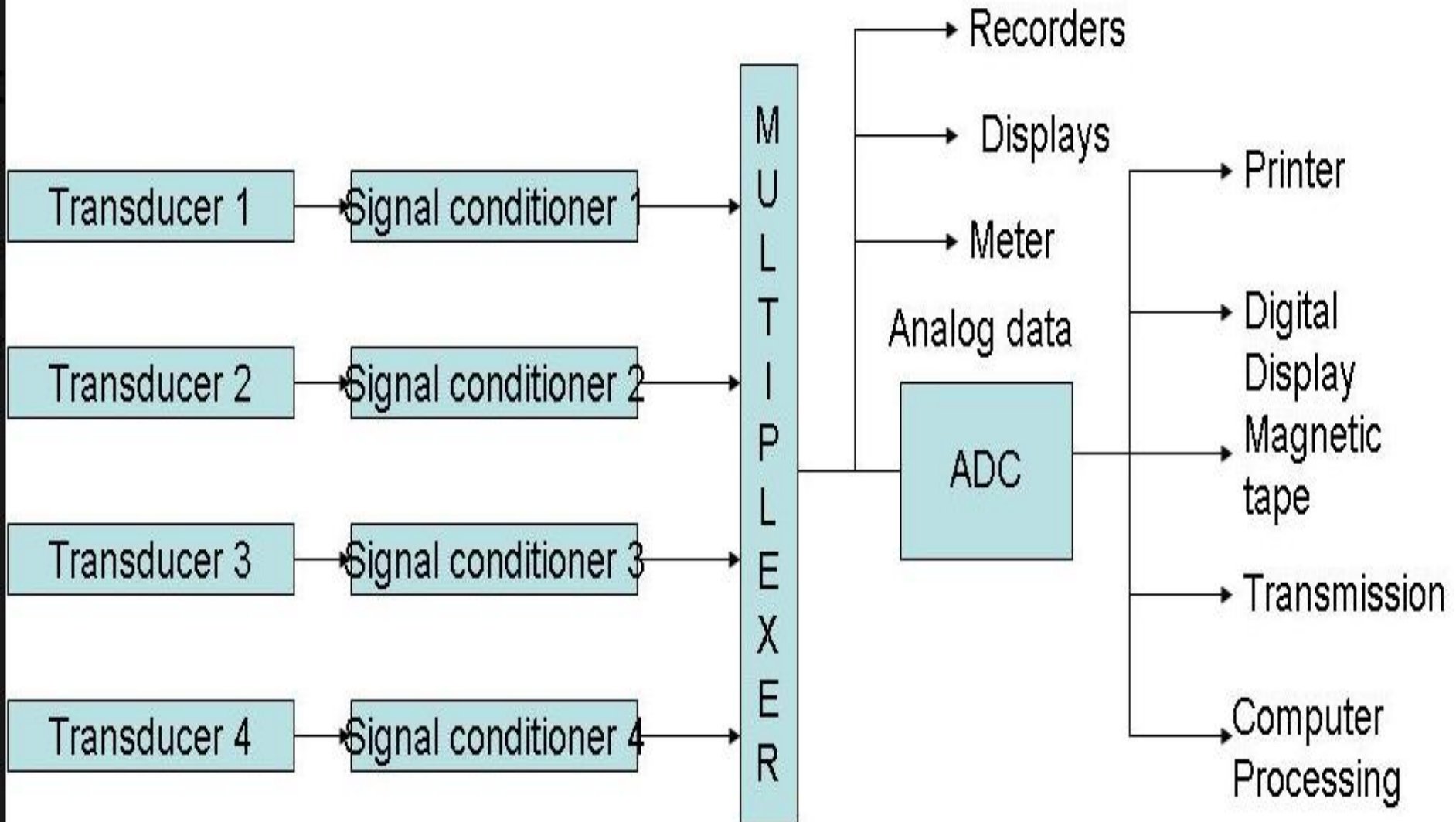

# Flow Of Information DAS

1. The input transducers **measure some property of the environment**.
2. The **output** from the transducers is **conditioned** (amplified, filtered..)
3. The conditioned analog signal is digitized using an analog-to-digital converter (ADC).
4. The digital information is acquired, processed and recorded by the computer.
5. The computer may then modify the environment by outputting control signals. The digital control signals are converted to analog signals using a digital-to-analog converter (DAC).
6. The analog signals are conditioned (e.g. amplified and filtered) appropriately for an output transducer.
7. The output transducer interacts with the environment.

# Transducers

- **Transducer is used to convert the physical quantity into an electrical signal.**

- **Examples:**

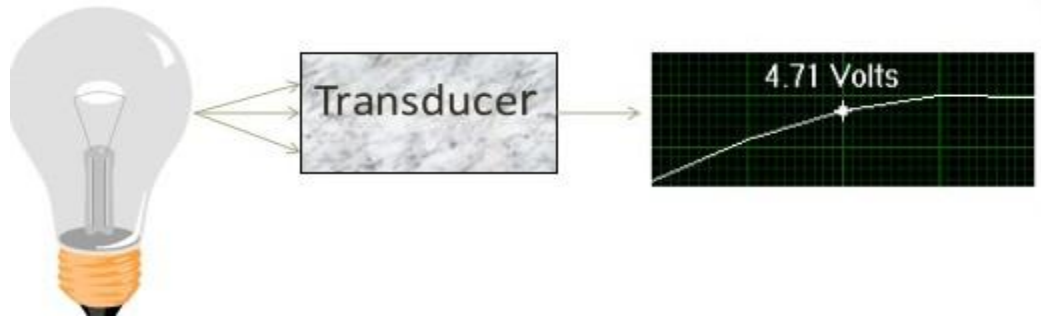

- **Strain gauge**
- **Thermocouple**
- **Piezoelectric device**
- The transducer generate a voltage proportional to physical quantity being measured.
- This voltage is applied to data acquisition system as a input.

# Signal Conditioning

- The output of transducer is a representation of physical signal, which we have to measure.
- This signal has to be modified before it becomes usable & satisfactory to drive the signal presentation stage.
- The proper representation of analog or digital signal obtained from the signal conditioning stage.
- The conditioning equipment required for process like
  - Amplification
  - Attenuation
  - Integration
  - Differentiation
  - **Subtraction**

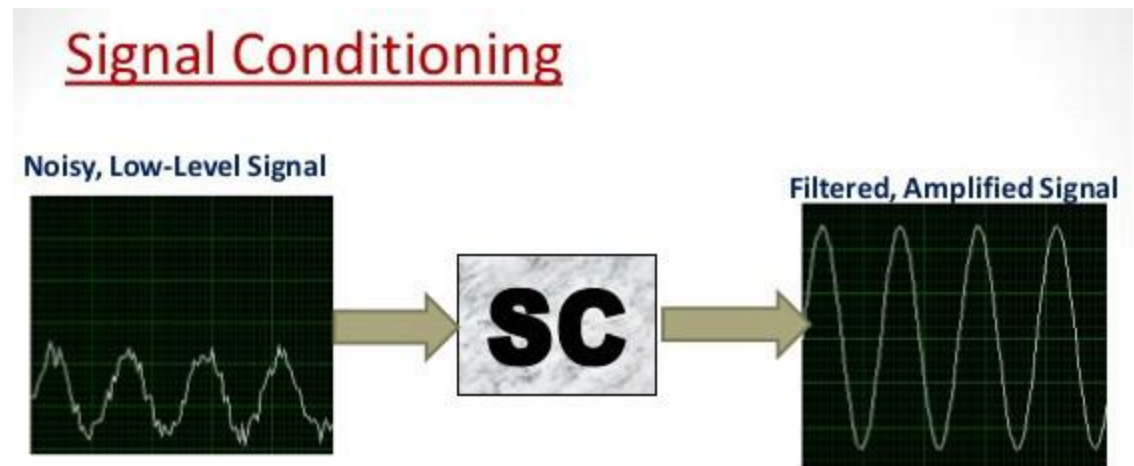

# Multiplexers

- It allows a single channel to share it with more than one input quantity.
- It accept multiple analog input.
- With the help of multiplexer we can transmit more than one quantity using same channel.
- The multiplexers are mostly used when many quantities are to be transmitted.
- Also when the distance between the source & distance is more multiplexers are used.
- Multiplexers reduce the cost of installation, maintenance & periodic replacement of channels if those are used for separate i/p signal

# Calibrating Equipment

- Before each test, the calibration is carried out. This is called precalibration.
- Similarly after each test calibration is carried out & it is called postcalibration.
- It is usually consists millivolt calibration of all i/p ckt & shunt calibration of all bridge type transducer.

# Visual display devices

- These are used to monitor the i/p signal continuously.
- These devices includes panel meters ,storage CRD ,CROs etc.

## □ **Analog recorders**

- These are required to record the o/p signal. The analog recorders includes the strip chart recorder, magnetic tape recorder etc.

# Single channel DAS

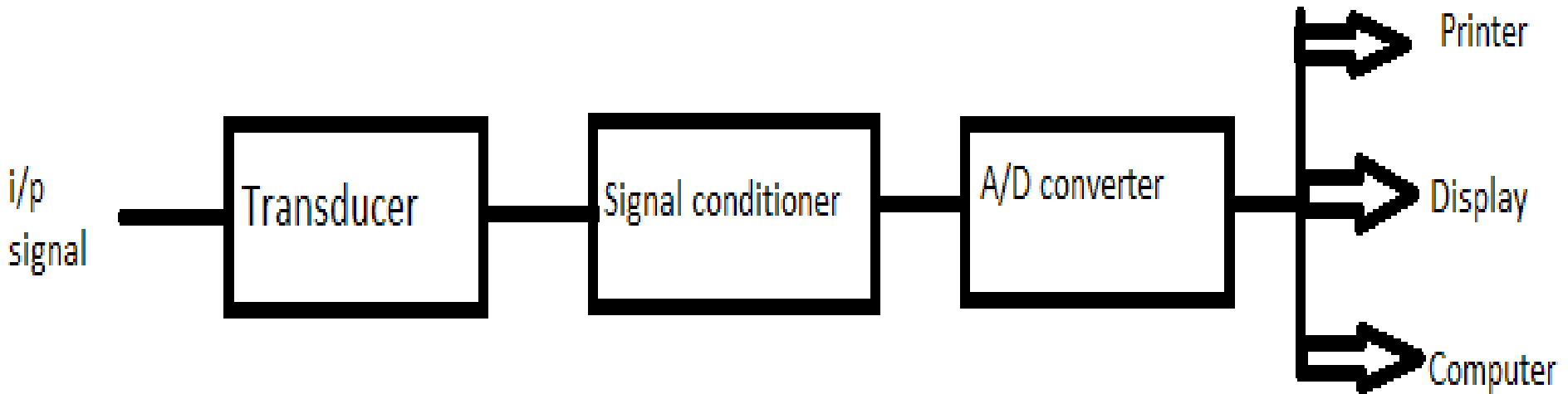

## Single channel DAS

It's basically working as the common analog DAS. Same components are used for it.

# Multichannel DAS

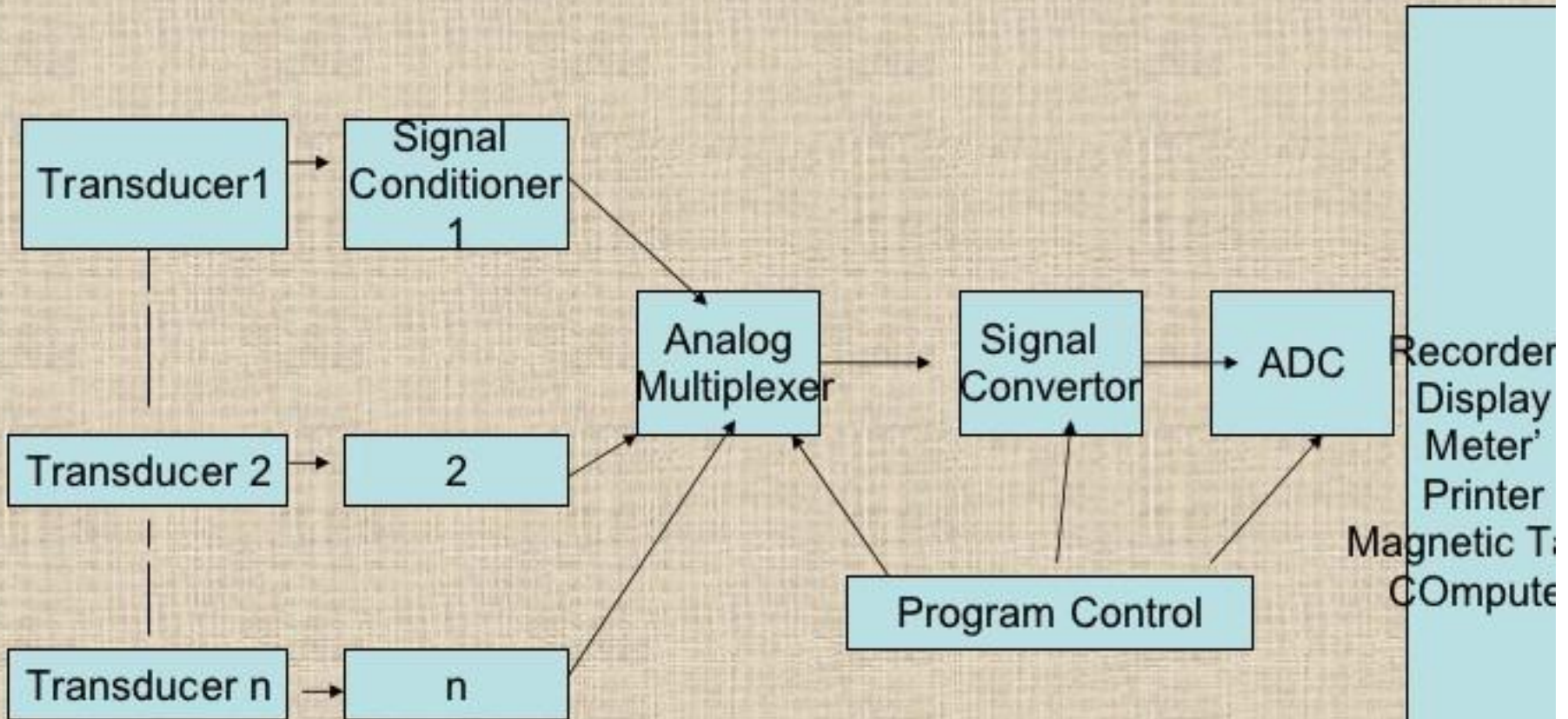

- The individual analog signals are applied to signal conditioning circuit. These signals are then multiplexed.
- Sample & Hold is used to store the previous data. This signal is then digitized.
- When conversion is complete the status line from converter causes the S/H to return to sample mode & acquires the signal of the next channel.

# Sample & Hold circuit

- Sample and hold circuits are used in linear systems.
- In some kinds of analog-to-digital converters, the input is compared to a voltage generated internally from a digital-to-analog converter (DAC).
- The circuit tries a series of values and stops converting once the voltages are equal, within some defined error margin.

- 
- In addition, sample and hold circuits are often used when multiple samples need to be measured at the same time.
  - Each value is sampled and held, using a common sample clock.

# Multichannel Analog Multiplexed System

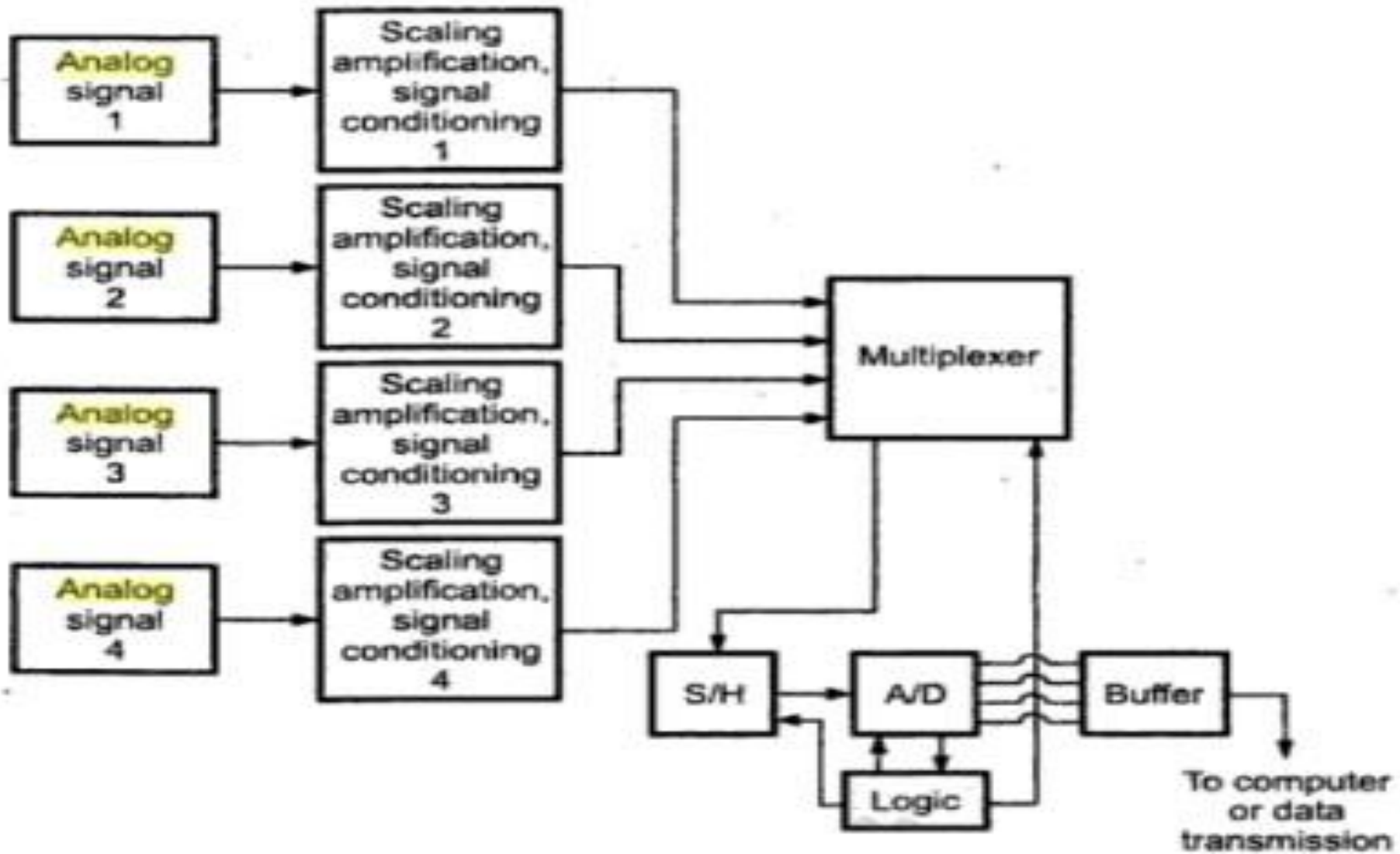

# Multichannel Analog Multiplexed System

- In this system, there is a **single analog to digital converted preceded by a multiplexer.**
- The individual analog signals are applied directly.
- They are amplified & signal conditioned to the multiplexer.
- Then analog to digital converter converts these analog signals to digital signals.
- For the utilization of time, the multiplexer gets or selects new channel to be converted while the previous data stored in the sample & hold circuit is converted into digital form.
- When this conversion completes, the status line from the converter makes the sample & hold circuit go back to sample mode.
- This process is comparatively slower but has the obvious advantage of low cost due to sharing of more than one channel.

# Multiplexed output of sample/hold circuit

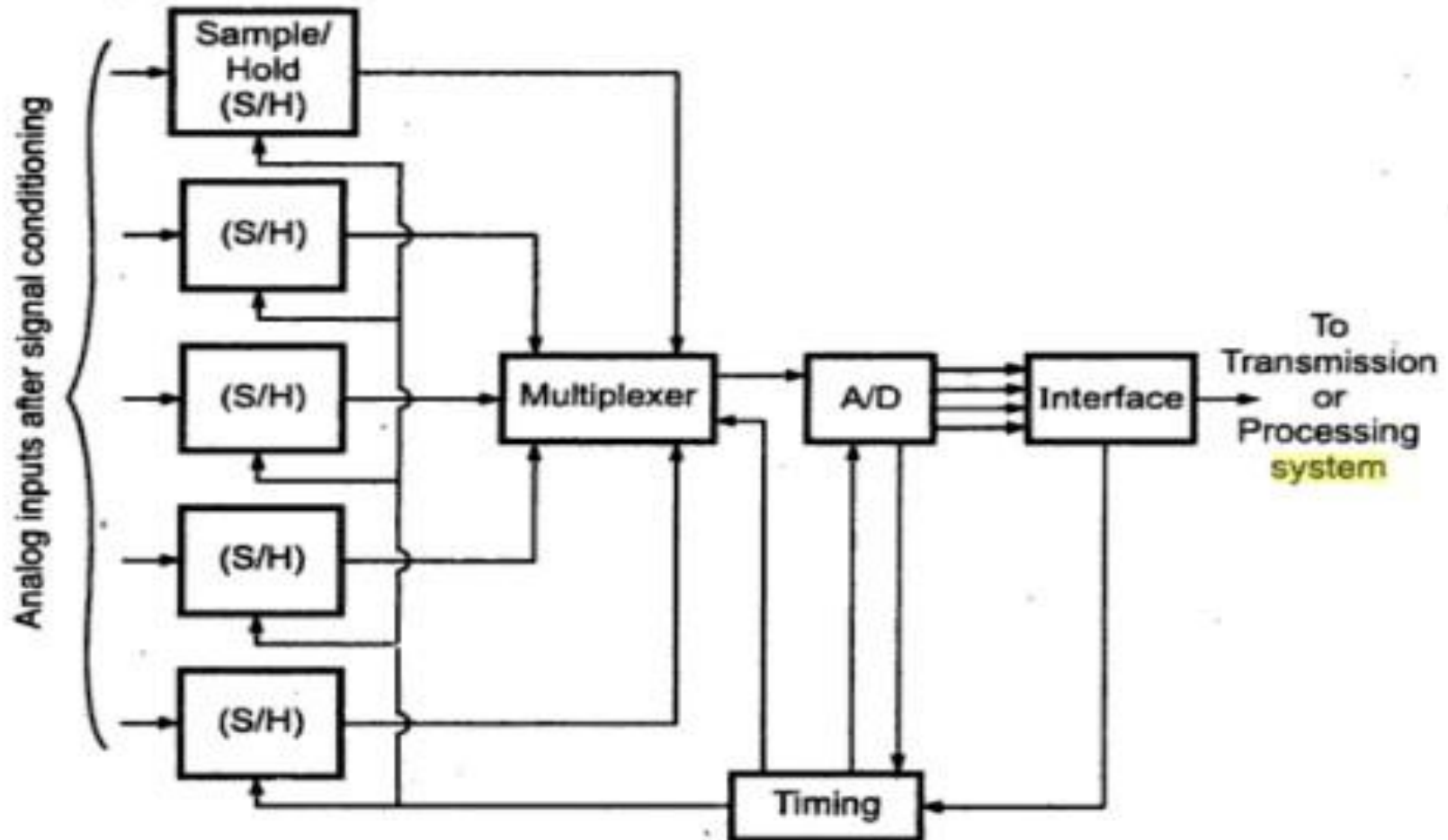

Fig. 6.4 Simultaneous sampled **system** multiplexer

# Multiplexed output of sample/hold circuit

- When more no of channels are to be monitored at the same time, the multiplexing of the o/p of sample & hold circuit is done.
- In this case, each sample & hold circuit is attached to each channel.
- They are synchronously updated by timing circuit.
- The sample & hold circuit are first multiplexed & then they are connected to analog to digital converter.
- The advantage of this multiplexing techniques is that this is moderately faster than earlier.

# Multiplexed After A/D CONVERSION

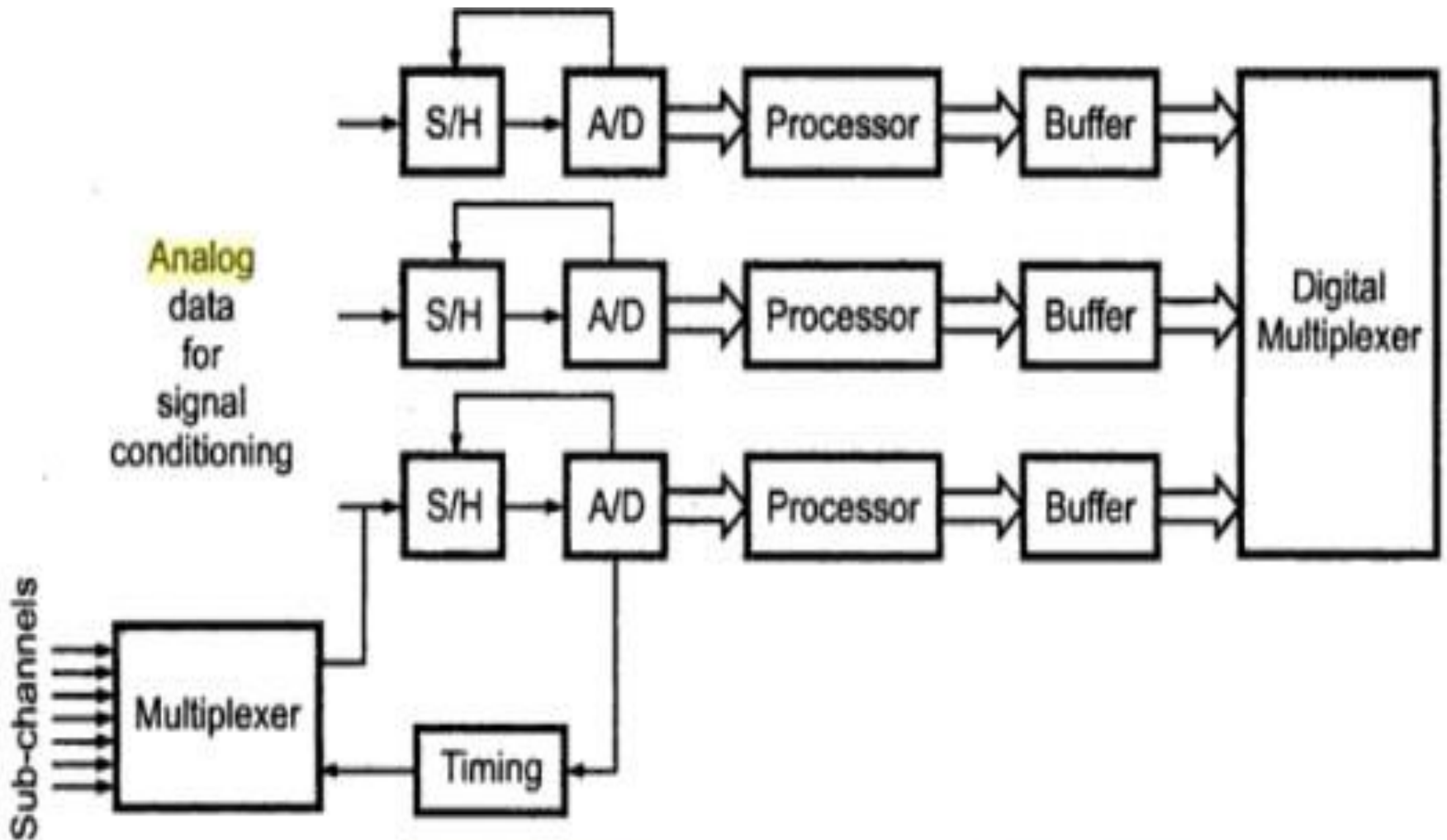

Fig. 9.5 Multichannel DAS using digital multiplexing

# Multiplexed After A/D CONVERSION

- In this techniques each sample& hold circuit & the **AtoD converter is assigned to the individual channel.**
- The conversion speed is as per the requirement.
- The technique is exhibiting **parallel conversion.**
- In industrial system, the number of strain gauge , thermocouples, LVDTs are distributed over large area.
- As the analog signal is digitized at the center , the data transmission provides great immunity against line frequency & other interferences.
  - ▣ The data in digital form performs logical operations.
- Based on relative speed at which changes occur in the data , the scanning rate can be increased or decreased.

# Application Of DAS

- used for collecting information.
- used for performing repeated calculations
- used to generate information for display.
- find application in aircraft control system.
- used in electrical power generation.
- used in industrial process system.
- used to convert data into useful form.

# Analog to Digital Converter

- Almost every environmental measurable parameter is in analog form like temperature, sound, pressure, light, etc.
- The system needs an intermediate device to convert the analog temperature data into digital data in order to communicate with the digital processors like microcontrollers and microprocessors.

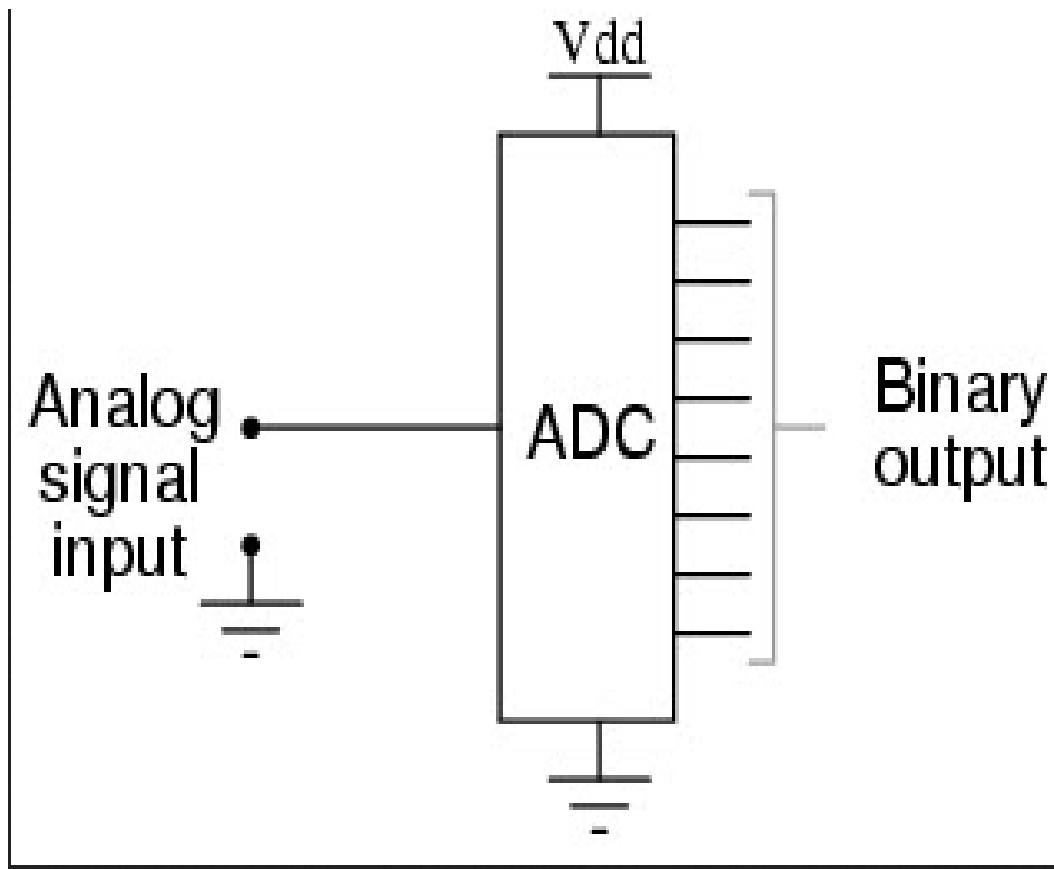

# Analog to Digital Converter

- Analog to Digital Converter (ADC) is an electronic integrated circuit used to convert the analog signals such as voltages to digital or binary form consisting of 1s and 0s.
- Most of the ADCs take a voltage input as 0 to 10V, -5V to +5V, etc. and correspondingly produces digital output as some sort of a binary number.

# Types of Analog to Digital Converters

Some of the types of analog to digital converters include:

- Dual Slope A/D Converter
- Flash A/D Converter
- Successive Approximation A/D Converter

# Dual Slope A/D Converter

- In this type of ADC converter comparison voltage is generated by using an integrator circuit which is formed by a resistor, capacitor and operational amplifier combination.
- By the set value of  $V_{ref}$ , this integrator generates a sawtooth waveform on its output from zero to the value  $V_{ref}$ .
- When the integrator waveform is started correspondingly counter starts counting from 0 to  $2^n - 1$  where  $n$  is the number of bits of ADC.
- When the input voltage  $V_{in}$  equal to the voltage of the waveform, then control circuit captures the counter value which is the digital value of corresponding analog input value.
- This Dual slope ADC is relatively medium cost and slow speed device.

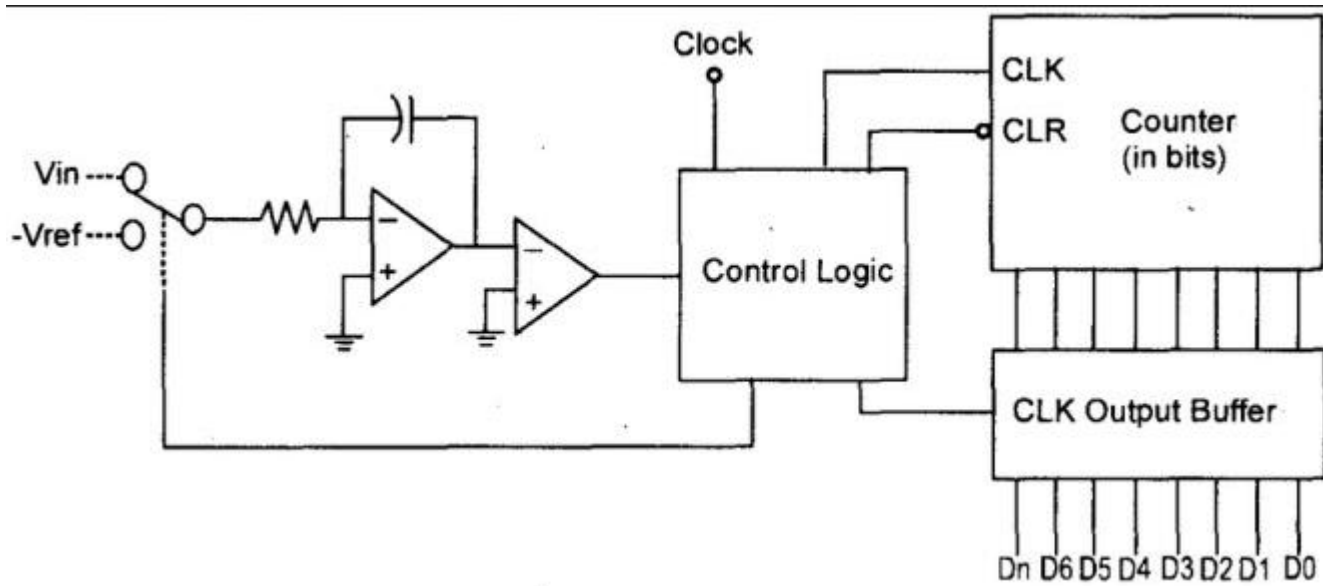

# Flash A/D Converter

- This ADC converter IC is also called as parallel ADC, which is a most widely used efficient ADC in terms of its speed.
- **This flash analog to digital converter circuit consists of a series of comparators where each one compares the input signal with a unique reference voltage.**
- At each comparator, the output will be high state when the analog input voltage exceeds the reference voltage.
- This output is further given to priority encoder for generating binary code based on higher order input activity by ignoring other active inputs.
- This flash type is a high-cost and high-speed device.

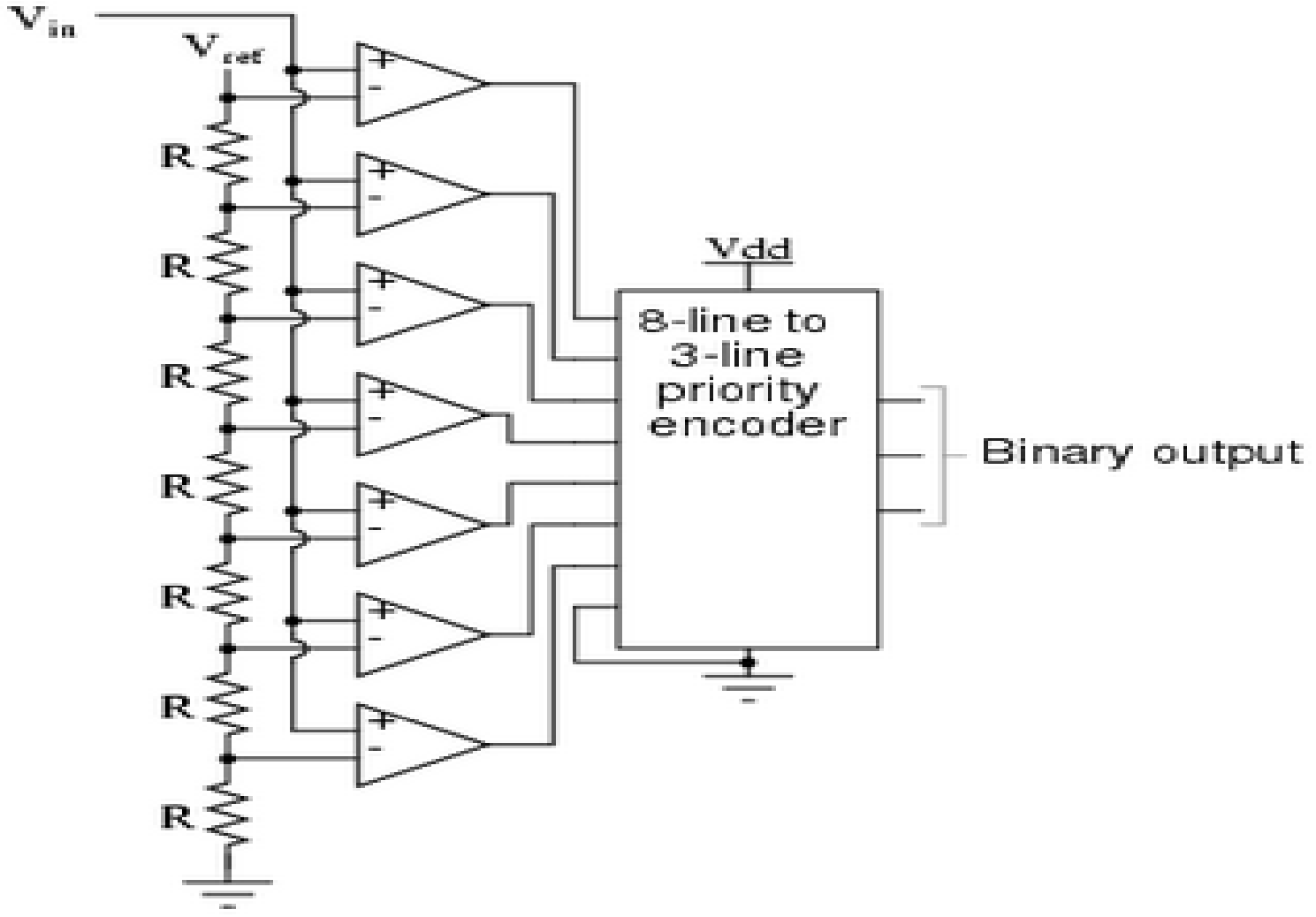

# Successive Approximation A/D Converter

- The SAR ADC is a most modern ADC IC and much faster than dual slope and flash ADCs since it uses a digital logic that converges the analog input voltage to the closest value.
- This circuit consists of a comparator, output latches, successive approximation register (SAR) and D/A converter.

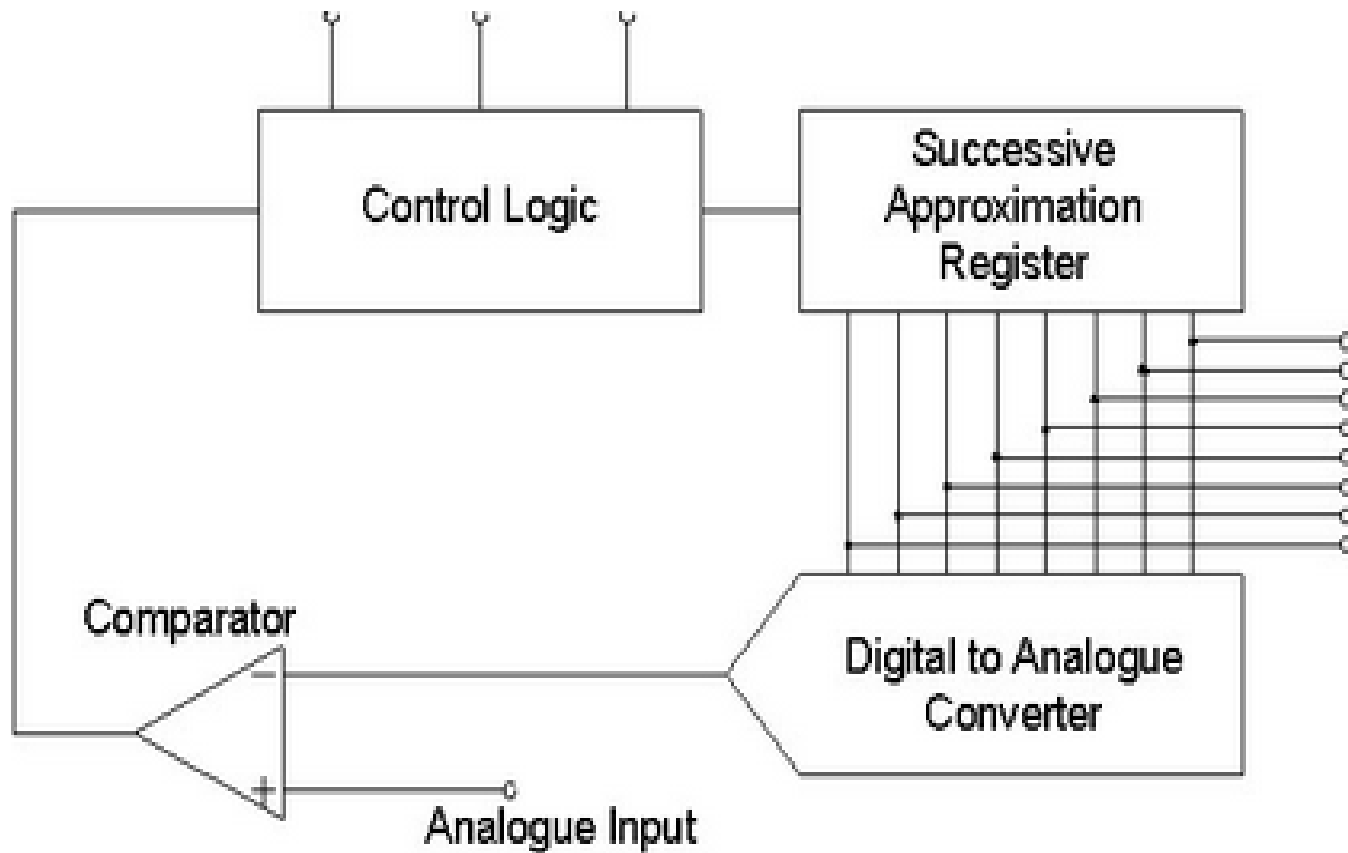

*Successive Approximation A/D Converter*

- At the start, SAR is reset and as the LOW to HIGH transition is introduced, the MSB of the SAR is set.
- Then this output is given to the D/A converter that produces an analog equivalent of the MSB, further it is compared with the analog input  $V_{in}$ .
- If comparator output is LOW, then MSB will be cleared by the SAR, otherwise the MSB will be set to the next position.
- This process continues till all the bits are tried and after  $Q_0$ , the SAR makes the parallel output lines to contain valid data.